

PROJECT PLAN

- Use the following table to list the major network build-out phases and milestones that can demonstrate that your entire project will be substantially complete by the end of Year 2 and fully complete by the end of Year 3. This is to be done at the aggregate level (combining all proposed funded service areas.)
- Indicated how the milestones listed below will demonstrate these completion objectives. The applicant should consider such project areas as: a) network design; b) securing all relevant licenses and agreements; c) site preparation; d) inside plant deployment; e) outside plan deployment; f) deployment of business & operational support systems; g) network testing; f) network operational. The applicant may provide any other milestones that it believes showcase progress.
- Project inception (Year 0) starts at the date when the applicant receives notice that the project has been approved for funding.
- In the table, provide any information (e.g., facts, analysis) to: a) demonstrate the reasonableness of these milestones; b) substantiate the ability to reach the milestones by the quarters indicated.

Time Period	Quarter	Milestones	Support for Reasonableness/Data Points
Year 0	-	<ul style="list-style-type: none"> • Commence implementation engineering. 	<ul style="list-style-type: none"> • Professional services for implementation preparation.
Year 1	Qtr. 1	<ul style="list-style-type: none"> • Implementation engineering ongoing. • Commence & complete router equipment installation. • Commence transport equipment installation. • • Commence access equipment installation. • • Commence outside plant construction. • • Commence & complete pre-fab building installation. • Commence customer premise equipment installation. • • 	<ul style="list-style-type: none"> • Professional services for implementation preparation. • Two (2) router equipment installers. • Eight (8) 2-man transport equipment installers working concurrently. • Ten (10) 2-man access equipment installers working concurrently. • Thirteen (13) 14-man outside plant construction crews working concurrently. • Four (4) pre-fab building crews. • Seven (7) 2-man CPE installation crews working concurrently.

	Qtr. 2	<ul style="list-style-type: none"> • Implementation engineering ongoing. • Transport equipment installation ongoing. • • Commence transport equipment installation. • Commence access equipment installation. • • Outside plant construction ongoing. • • Customer premise equipment installation ongoing. • 	<ul style="list-style-type: none"> • Professional services for implementation preparation. • Eight (8) 2-man transport equipment installers working concurrently. • Seven (7) 2-man access equipment installers working concurrently. • Seven (7) 14-man outside plant construction crews working concurrently. • Three (3) 2-man CPE installation crews working concurrently.
	Qtr. 3	<ul style="list-style-type: none"> • Implementation engineering ongoing. • • Transport equipment installation complete. • • Access equipment installation complete. • • Outside plant construction ongoing. • • Customer premise equipment installation ongoing. • 	<ul style="list-style-type: none"> • Professional services for implementation preparation. • Two (2) 2-man transport equipment installers working concurrently. • Four (4) 2-man access equipment installers working concurrently. • Seven (7) 14-man outside plant construction crews working concurrently. • Three (3) 2-man CPE installation crews working concurrently.
	Qtr. 4	<ul style="list-style-type: none"> • Implementation engineering ongoing. • • Outside plant construction ongoing. • • Customer premise equipment installation complete. • 	<ul style="list-style-type: none"> • Professional services for implementation preparation. • Five (5) 14-man outside plant construction crews working concurrently. • One (1) 2-man CPE installation crew.

Year 2	Qtr. 1	<ul style="list-style-type: none"> • Implementation engineering ongoing. • • Outside plant construction ongoing. • 	<ul style="list-style-type: none"> • Professional services for implementation preparation. • Three (3) 14-man outside plant construction crews working concurrently.
	Qtr. 2	<ul style="list-style-type: none"> • Implementation engineering ongoing. • • Outside plant construction ongoing. • 	<ul style="list-style-type: none"> • Professional services for implementation preparation. • Two (2) 14-man outside plant construction crews working concurrently.
	Qtr. 3	<ul style="list-style-type: none"> • Implementation engineering complete. • • Outside plant construction complete. • • Project complete. 	<ul style="list-style-type: none"> • Professional services for implementation preparation. • One (1) 14-man outside plant construction crews working concurrently.
	Qtr. 4	<ul style="list-style-type: none"> • List all relevant milestones 	<ul style="list-style-type: none"> •
Year 3	Qtr. 1	<ul style="list-style-type: none"> • List all relevant milestones 	<ul style="list-style-type: none"> •
	Qtr. 2	<ul style="list-style-type: none"> • List all relevant milestones 	<ul style="list-style-type: none"> •
	Qtr. 3	<ul style="list-style-type: none"> • List all relevant milestones 	<ul style="list-style-type: none"> •

	Qtr. 4	<ul style="list-style-type: none">List all relevant milestones	<ul style="list-style-type: none">
--	--------	--	--

BUILD-OUT TIMELINE

Complete the following schedule for *each* Last Mile or Middle Mile Service Area to note the degree of build-out, based on: a) infrastructure funds awarded; b) entities passed (households, businesses, and community anchor institutions.). In addition, please complete a schedule that aggregates the build-out timeline across all of the Proposed Funded Service Area.

Service Area	[Fill Name]												
	YEAR 0	YEAR 1				YEAR 2				YEAR 3			
		Qtr. 1	Qtr. 2	Qtr. 3	Qtr. 4	Qtr. 1	Qtr. 2	Qtr. 3	Qtr. 4	Qtr. 1	Qtr. 2	Qtr. 3	Qtr. 4
Infrastructure Funds	\$3,857,466	\$21,881,181	\$34,522,698	\$42,452,836	\$48,501,248	\$53,522,884	\$56,911,754	\$58,173,226					
Infrastructure Funds Advanced (estimate)	\$9,073,011	\$5,912,632	\$3,930,097	\$2,417,995	\$1,162,586	\$315,356							
Percentage of Total Funds	06.6%	37.6%	59.3%	72.9%	83.3%	92.0%	97.6%	100%					
Entities Passed & %													
Households		147,836	261,563	368,737	443,211	496,399	528,019	538,559					
Percentage of Total Households		27.45%	48.57%	68.47%	82.30%	92.17%	98.04%	100.00%					
Businesses		28,336	50,137	70,682	84,957	95,150	101,210	103,230					
Percentage of Total Businesses		27.45%	48.57%	68.47%	82.30%	92.17%	98.04%	100.00%					
Community Anchor Institutions		490	871	1,229	1,478	1,655	1,760	1,795					
Percentage of Total Institutions		27.30%	48.52%	68.47%	82.34%	92.20%	98.05%	100.00%					

ADOPTION NOTICE

ADOPTION OF TARIFFS, ETC.

CenturyTel of Washington, Inc. d/b/a CenturyLink, hereby adopts and makes its own in every respect all tariffs, supplements and amendments filed with the Washington Utilities and Transportation Commission by CenturyTel of Washington, Inc. d/b/a CenturyTel prior to October 19, 2009.

(N)

Tariff Adopted: WN U-4

Transfer Authorized
By Order No. 05 in Docket UT-082119

(N)

CenturyTel of Washington, Inc. d/b/a CenturyTel hereby adopts, ratifies, and makes its own in every respect, as if the same had been originally filed by it, all tariffs, rules, notices, concurrences, provisions, authorities, power of attorney or whatever other instruments filed with the Washington Utilities and Transportation Commission or its predecessors by Telephone Utilities of Washington, Inc., dba PTI Communications prior to May 8, 1998. By this notice, it also adopts and ratifies all supplements or amendments to any of the above tariffs, etc. which have heretofore been filed with the Washington Utilities and Transportation Commission or its predecessors.

Tariff Adopted:

WN U-4

ACCESS SERVICE

REGULATIONS, RATES AND CHARGES

Applying to the provision of Access Services
for
connection to Intrastate Communications Facilities
for Intrastate IntraLATA and InterLATA Customers within the
operating territories of the

CenturyTel of Washington, Inc.
d/b/a CenturyLink (Issuing Utility) (C)

CenturyTel of Inter Island, Inc.
d/b/a CenturyLink (Issuing and Concurring Utility)* (C)

CenturyTel of Cowiche, Inc.
d/b/a CenturyLink (Issuing and Concurring Utility)* (C)

in the state of Washington

* CenturyTel of Inter Island, Inc. d/b/a CenturyLink, (as both an issuing and concurring Utility) (C)
delegates its issuing authority in this tariff to CenturyTel of Washington, Inc. d/b/a CenturyLink. (C)

* CenturyTel of Cowiche, Inc. d/b/a CenturyLink, (as both an issuing and concurring Utility) (C)
delegates its issuing authority in this tariff to CenturyTel of Washington, Inc. d/b/a CenturyLink. (C)

ACCESS SERVICE

ISSUING CARRIERS

CENTURYTEL OF WASHINGTON, INC.
d/b/a CENTURYLINK (C)

CENTURYTEL OF INTER ISLAND, INC.
d/b/a CENTURYLINK (C)

CENTURYTEL OF COWICHE, INC.
d/b/a CENTURYLINK (C)

ACCESS SERVICE

TABLE OF CONTENTS

	<u>Page No.</u>
Concurring Carriers	1
Connecting Carriers	1
Other Participating Carriers	1
Explanation of Symbols	2
Explanation of Abbreviations	2
Reference to Other Tariffs	4
Reference to Technical Publications	5
1. <u>APPLICATION OF TARIFF</u>	7
2. <u>GENERAL REGULATIONS</u>	8
2.1 <u>Undertaking of the Telephone Company</u>	
2.1.1 Scope	8
2.1.2 Limitations	9
2.1.3 Liability	10
2.1.4 Provision of Services	12
2.1.5 Installation and Termination of Services	12
2.1.6 Maintenance of Services	12
2.1.7 Changes and Substitutions	12
2.1.8 Refusal and Discontinuance of Service	13
2.1.9	15
2.1.10 Limitation of Use of Metallic Facilities	15
2.1.11 Notification of Service-Affecting Activities	15
2.1.12 Coordination with Respect to Network contingencies	15
2.1.13 Provision and Ownership of Telephone Numbers	16
2.1.14 Warrant of Facilities and Services	16
2.2 <u>Use</u>	16
2.2.1	16
2.2.2 Interference or Impairment	16
2.2.3 Unlawful Use	17

Advice No. 03-28

Issued July 23, 2003

Effective August 23, 2003

Issued By CENTURYTEL OF WASHINGTON, INC. d/b/a CenturyTel

P.O. Box 9901, Vancouver, WA

(C)

By Pamela Donovan

Title Supervisor, Tariffs

ACCESS SERVICE

TABLE OF CONTENTS (Cont'd)

	<u>Page No.</u>
2. <u>GENERAL REGULATIONS (Cont'd)</u>	
2.3 <u>Obligation of the Customer</u>	
2.3.1 Damages	18
2.3.2 Ownership of Facilities and Theft	18
2.3.3 Equipment Space and Power	18
2.3.4	19
2.3.5	19
2.3.6 Availability for Testing	19
2.3.7 Balance	19
2.3.8 Design of Customer Services	20
2.3.9 Reference to the Telephone Company	20
2.3.10	20
2.3.11 Claims and Demands for Damages	20
2.3.12	21
2.3.13 Coordination with Respect to Network Contingencies	22
2.3.14 Jurisdictional Report Requirements	22
2.3.15 Determination of Interstate Charges for Mixed Interstate and Intrastate Access Service	27
2.4 <u>Payment Arrangements and Credit Allowances</u>	28
2.4.1 Payment of Rates Charges and Deposits	28
2.4.2 Minimum Periods	33
2.4.3 Cancellation of an Order for Service	34
2.4.4 Credit Allowance for Service Interruptions	34
2.4.5	39
2.4.6 Re-establishment of Service Following Fire, Flood or Other Occurrence	39
2.4.7 Title or Ownership Rights	39
2.4.8 Ordering, Rating and Billing of Access Services Where More Than One Exchange Telephone Company is Involved	40
2.5 Connections	44
2.5.1 General	44

Advice No. 03-28

Issued July 23, 2003

Effective August 23, 2003

Issued By CENTURYTEL OF WASHINGTON, INC. d/b/a CenturyTel
 P.O. Box 9901, Vancouver, WA

(C)

By Pamela Donovan Title Supervisor, Tariffs

ACCESS SERVICE

TABLE OF CONTENTS (Cont'd)

		<u>Page No.</u>
2.	<u>GENERAL REGULATIONS</u> (Cont'd)	
2.6	<u>Definitions</u>	45
	Access Code	45
	Access Minutes	45
	Access Tandem	45
	Answer/Disconnect Supervision	45
	Attenuation Distortion	46
	Balance (100 Type) Test Line	46
	Bit	46
	Business Day	46
	Busy Hour Minutes of Capacity	47
	Call	47
	Carrier or Common Carrier	47
	CCS	48
	Central Office	48
	Central Office Prefix	48
	Centralized Automatic Reporting on Trunks Testing	48
	Channel(s)	49
	Channel Service Unit	49
	Channelize	49
	C-Message Noise	49
	C-Notched Noise	49
	Coin Station	50
	Common Carrier	50
	Common Line	50
	Communications System	50
	Customer	50
	Data Transmission (107 Type) Test Line	51
	Decibel	51
	Decibel Reference Noise C-Message Weighting	51
	Decibel Reference Noise C-Message Reference to 0	51
	Detail Billing	51
	Dialing Parity	51
	Direct Trunked Transport	51
	Directory Assistance (Intrastate)	51
	Dual Tone Multifrequency Address Signaling	52
	Echo Control	52
	Echo Path Loss	52
	Echo Return Loss	52

Advice No. 03-28

Issued July 23, 2003

Effective August 23, 2003

Issued By CENTURYTEL OF WASHINGTON, INC. d/b/a CenturyTel
 P.O. Box 9901, Vancouver, WA

(C)

By Pamela Donovan Title Supervisor, Tariffs

ACCESS SERVICE

TABLE OF CONTENTS (Cont'd)

		<u>Page No.</u>
2.	<u>GENERAL REGULATIONS</u> (Cont'd)	
2.6	<u>Definitions</u> (Cont'd)	
	Effective 2-Wire	52
	Effective 4-Wire	53
	End Office Switch	53
	End User	53
	Entrance Facility	53
	Entry Switch	53
	Envelope Delay Distortion	54
	Equal Level Echo Path Loss	54
	Expected Measured Loss	54
	Exchange	54
	Field Identifier	54
	First Come - First Served	55
	First Point of Switching	55
	Frequency Shift	55
	Grandfathered	56
	Host Office	56
	Immediately Available Funds	56
	Impedance Balance	56
	Impulse Noise	56
	Individual Case Basis	56
	Inserted Connection Loss	57
	Interexchange Carrier (IC) or Interexchange Common Carrier	57
	Intermodulation Distortion	57
	Interstate Communications	57
	Intrastate Communications	58
	Line Side Connection	58
	Local Access and Transport Area	58
	Local Tandem Switch	58
	Loop Around Test Line	58
	Loss Deviation	59
	Message	59
	Milliwatt (102 Type) Test Line	59
	Network Control Signaling	59
	Nonsynchronous Test Line	59

Advice No. 03-28

Issued July 23, 2003

Effective August 23, 2003

Issued By CENTURYTEL OF WASHINGTON, INC. d/b/a CenturyTel
 P.O. Box 9901, Vancouver, WA

(C)

By Pamela Donovan Title Supervisor, Tariffs

ACCESS SERVICE

TABLE OF CONTENTS (Cont'd)

		<u>Page No.</u>
2.	<u>GENERAL REGULATIONS</u> (Cont'd)	
2.6	Definitions (Cont'd)	
	North American Numbering Plan	60
	Off-Hook	60
	On-Hook	60
	Open Circuit Test Line	60
	Originating Direction	60
	Pay Telephone	60
	Phase Jitter	61
	Point of Termination	61
	Premises	61
	Query	61
	Remote Switching Modules and/or Remote Switching Systems	61
	Return Loss	61
	Registered Equipment	62
	Service Switching Point	62
	Seven Digit Manual Test Line	62
	Short Circuit Test Line	62
	Shortage of Facilities or Equipment	62
	Signal-To-C-Notched Noise Ratio	62
	Singing Return Loss	62
	Special Order	62
	Subscriber Lines	63
	Subtending End Office of an Access Tandem	63
	Synchronous Test Line	63
	Tandem Switched Transport	63
	Terminating Direction	63
	Transmission Measuring (I05 Type) Test Line/Responder	63
	Transmission Path	63
	Trunk	64
	Trunk Group	64
	Trunk Side Connection	64
	Two-Wire to Four-Wire Conversion	64
	Uniform Service Order Code (USOC)	64
	V&H Coordinates Method	65
	Wire Center	65

Advice No. 03-28

Issued July 23, 2003

Effective August 23, 2003

Issued By CENTURYTEL OF WASHINGTON, INC. d/b/a CenturyTel

P.O. Box 9901, Vancouver, WA

By Pamela Donovan

Title Supervisor, Tariffs

(C)

ACCESS SERVICE

TABLE OF CONTENTS (Cont'd)

	<u>Page No.</u>
3. <u>CARRIER COMMON LINE ACCESS SERVICE</u>	66
3.1 <u>General Description</u>	66
3.2 <u>Regulations, Rates and Charges</u>	66
4.	67
5. <u>ORDERING OPTIONS FOR SWITCHED AND SPECIAL ACCESS SERVICE</u>	68
5.1 <u>General</u>	68
5.1.1 Ordering Conditions	68
5.1.2 Provision of Other Services	69
5.1.3 Special Construction	70
5.2 <u>Access Order</u>	70
5.2.1 Access Order Service	73
5.2.2 Access Order Modifications	74
5.2.3 Cancellation of an Access Order	79
5.2.4 Selection of Planned Facilities For Access Orders	81
5.2.5 Minimum Period	81
5.2.6 Minimum Period Charges	82
5.2.7 Shared Use Facilities	82

Advice No. 03-28

Issued July 23, 2003

Effective August 23, 2003

Issued By CENTURYTEL OF WASHINGTON, INC. d/b/a CenturyTel

P.O. Box 9901, Vancouver, WA

By Pamela Donovan

Title Supervisor, Tariffs

(C)

ACCESS SERVICE

TABLE OF CONTENTS (Cont'd)

	<u>Page No.</u>
6. <u>SWITCHED ACCESS SERVICE</u>	83
6.1 <u>General</u>	83
6.1.1 Feature Group Arrangements and Manner of Provision	83
6.1.2 Dedicated Access Line Service	87
6.1.3 Rate Categories	87
6.1.4 Special Facilities Routing	100
6.1.5 Design Layout Report	100
6.1.6 Acceptance Testing	100
6.1.7 Ordering Options and Conditions	100

Advice No. 03-28

Issued July 23, 2003

Effective August 23, 2003

Issued By CENTURYTEL OF WASHINGTON, INC. d/b/a CenturyTel

P.O. Box 9901, Vancouver, WA

By Pamela Donovan

Title Supervisor, Tariffs

(C)

ACCESS SERVICE

TABLE OF CONTENTS (Cont'd)

		<u>Page No.</u>
6.	<u>SWITCHED ACCESS SERVICE</u> (Cont'd)	101
6.2	<u>Provision and Description of Switched Access Service Feature Groups</u>	101
6.2.1	Feature Group A	102
6.2.2	Feature Group B	108
6.2.3	Feature Group C	112
6.2.4	Feature Group D	117
6.2.5	800 Access Service	123.1
6.3	<u>Common Switching and Transport Termination Nonchargeable Optional Features</u>	124
6.3.1	Common Switching Optional Features	124
6.3.2	Transport Termination Optional Features	132
6.4	<u>Transmission Performance Specifications</u>	136
6.4.1	Standard Transmission Specifications	137
6.4.2	Data Transmission Parameters	144
6.5	<u>Obligations of the Telephone Company</u>	147
6.5.1	Network Management	147
6.5.2	Design and Traffic Routing of Switched Access Service	147
6.5.3	Provision of Service Performance Data	148
6.5.4	Trunk Group Measurement Reports	149
6.5.5	Determination of Number of Transmission Paths	149
6.5.6	Determination of Number of End Office Transport Terminations	149
6.5.7	Design Blocking Probability	149
6.6	<u>Obligations of the Customer</u>	152
6.6.1	Report Requirements 1	152
6.6.2	Supervisory Signaling	153
6.6.3	Trunk Group Measurement Reports	153

Advice No. 03-28

Issued July 23, 2003

Effective August 23, 2003

Issued By CENTURYTEL OF WASHINGTON, INC. d/b/a CenturyTel

P.O. Box 9901, Vancouver, WA

(C)

By Pamela Donovan

Title Supervisor, Tariffs

ACCESS SERVICE

TABLE OF CONTENTS (Cont'd)

	<u>Page No.</u>
7. <u>SPECIAL ACCESS SERVICE</u>	185
7.1 <u>General</u>	185
7.1.1 Rate Categories	185
7.1.2 Facility Interface Combinations	188
7.1.3 Optional Miscellaneous Functions	188
7.1.4 Service Configurations	188
7.1.5 Alternate Use	192
7.1.6 Special Facilities Routing	192
7.1.7 Design Layout Report	192
7.1.8 Acceptance Testing	193
7.1.9 Ordering Options and Conditions	193
7.2 <u>Technical Service Descriptions for Special Access Service</u>	194
7.2.1 Analog Services	195
7.2.2 Digital Services	211
7.2.3 Service Designator/Network Channel Code Conversion Table	217
7.3 <u>Optional Facility Interface Codes</u>	218
7.3.1 Glossary of Optional Facility Interface Codes and Options	218
7.3.2 Impedance	222
7.4 <u>Rate Regulations</u>	223
7.4.1 Types of Rates and Charges	224
7.4.2 Surcharge for Special Access Service	226
7.4.3 Minimum Periods	230
7.4.4 Moves	230
7.4.5 Rate Application Exception Rules	231
7.4.6 Mileage Measurement	233

Advice No. 03-28

Issued July 23, 2003

Effective August 23, 2003

Issued By CENTURYTEL OF WASHINGTON, INC. d/b/a CenturyTel
 P.O. Box 9901, Vancouver, WA

(C)

By Pamela Donovan Title Supervisor, Tariffs

ACCESS SERVICE

TABLE OF CONTENTS (Cont'd)

		<u>Page No.</u>
8.	<u>BILLING AND COLLECTION SERVICES</u>	248
8.1	<u>Recording Service</u>	248
8.1.1	General Description	249
8.1.2	Undertaking of the Telephone Company	250
8.1.3	Liability of the Telephone Company	254
8.1.4	Obligations of the Customer	255
8.1.5	Payment Arrangements and Audit Provision	256
8.1.6	Rate Regulations	259
8.2	<u>Billing Service</u>	261
8.2.1	<u>Message Billing Service</u>	262
8.2.2		287
8.2.3	Purchase of Accounts Receivable	288
8.2.4	Billing Arrangements when the Telephone Company Acts as Billing Agent for the Customer	295
8.3	<u>Billing Analysis Service</u>	296
8.3.1	General Description	296
8.3.2	Undertaking of the Telephone Company	297
8.3.3	Liability of the Telephone Company	303
8.3.4	Obligations of the Customer	304
8.3.5	Payment Arrangements	305
8.3.6	Rate Regulations	307
8.4	<u>Billing Information Service</u>	308
8.4.1	General Description	308
8.4.2	Undertaking of the Telephone Company	308
8.4.3	Liability of the Telephone Company	315
8.4.4	Obligations of the Customer	316
8.4.5	Payment Arrangements	318
8.4.6	Rate Regulations	319

Advice No. 03-28

Issued July 23, 2003

Effective August 23, 2003

Issued By CENTURYTEL OF WASHINGTON, INC. d/b/a CenturyTel
 P.O. Box 9901, Vancouver, WA

(C)

By Pamela Donovan Title Supervisor, Tariffs

ACCESS SERVICE

TABLE OF CONTENTS (Cont'd)

	<u>Page No.</u>	
12. <u>SPECIALIZED SERVICE OR ARRANGEMENTS</u>	338	
12.1 <u>General</u>	338	
12.2 <u>Ethernet Service</u>	338.1	(N)
12.2.1 General	338.1	
12.2.2 Service Description	338.2	
12.2.3 Obligations of the Customer	338.3	
12.2.4 Multiple Party Connections	338.3	
12.2.5 Rate Categories	338.4	
12.2.6 Application of Rates	338.7	
12.2.7 Rate Regulations	338.10	(N)
13. <u>ADDITIONAL ENGINEERING, ADDITIONAL LABOR AND MISCELLANEOUS CHARGES</u>	339	
13.1 <u>Additional Engineering</u>	339	
13.2 <u>Additional Labor</u>	340	
13.2.1 Overtime Installation	340	
13.2.2 Overtime Repair	340	
13.2.3 Standby	341	
13.2.4 Testing and Maintenance with Other Telephone Companies	341	
13.2.5 Other Labor	341	
13.3 <u>Miscellaneous Services</u>	344	
13.3.1 Maintenance of Service	344	
13.3.2 Restoration Priority	346	
13.3.3 Presubscription	346	
13.3.4 Standard Jacks - Registration Program	351	
13.3.5 Testing Services	355	
13.3.6 Provision of Access Service Billing Information	360	
14. <u>EXCEPTIONS TO ACCESS SERVICE OFFERINGS</u>	361	
15. <u>RATE CENTERS</u>	362	
15.1 <u>Location Information</u>	362	
15.2 <u>Service Information</u>	365	
15.3 <u>Listing of Office Type Codes</u>	368	

Advice No. 08-05

Issued February 22, 2008

Effective March 23, 2008

Issued By CENTURYTEL OF WASHINGTON, INC. d/b/a CenturyTel
 P.O. Box 9901, Vancouver, WA

By Chantel Mosby Title Manager, Tariffs and Compliance

ACCESS SERVICE

TABLE OF CONTENTS (Cont'd)

	<u>Page No.</u>
16. <u>RATES AND CHARGES</u> For CenturyTel of Washington, Inc. & CenturyTel of Inter Island, Inc.	370
16.1 <u>Carrier Common Line Access Service</u>	371
16.2 <u>Access Ordering</u>	371
16.3 <u>Switched Access Service</u>	372
16.3.1 Nonrecurring Charges	372
16.3.2 Local Transport	373
16.3.3 End Office	377
16.4 <u>Special Access Service</u>	378
16.4.1 Nonrecurring Charges	378
16.4.2 Special Access Surcharge	380
16.4.3 Special Access Lines	381
16.4.4 High Capacity Service	383
16.5 <u>Other Services</u>	386
16.5.1 Additional Engineering	386
16.5.2 Additional Labor	387
16.5.3 Miscellaneous Services	389
16.5.4 Special Federal Government Access Services	390
16.5.5 Special Facilities Routing of Access Services	391
16.5.6 Specialized Service or Arrangements	392
16.5.7 Billing and Collection	393
16.5.8 Ethernet Service Rates	397.1 (N)

Advice No. 08-05

Issued February 22, 2008	Effective March 23, 2008
Issued By	CENTURYTEL OF WASHINGTON, INC. d/b/a CenturyTel
	P.O. Box 9901, Vancouver, WA
By	Chantel Mosby
	Title Manager, Tariffs and Compliance

ACCESS SERVICE

TABLE OF CONTENTS (Cont'd)

	<u>Page No.</u>
17. <u>RATES AND CHARGES</u> For CenturyTel of Cowiche, Inc.	396
17.1 <u>Carrier Common Line Access Service</u>	397
17.2 <u>Access Ordering</u>	397
17.3 <u>Switched Access Service</u>	398
17.3.1 Nonrecurring Charges	398
17.3.2 Local Transport	399
17.3.3 End Office	403
17.4 <u>Special Access Service</u>	404
17.4.1 Nonrecurring Charges	404
17.4.2 Special Access Surcharge	406
17.4.3 Special Access Lines	407
17.4.4 High Capacity Service	409
17.5 <u>Other Services</u>	412
17.5.1 Additional Engineering	412
17.5.2 Additional Labor	413
17.5.3 Miscellaneous Services	415
17.5.4 Special Federal Government Access Services	417
17.5.5 Special Facilities Routing of Access Services	418
17.5.6 Specialized Service or Arrangements	419
17.5.7 Billing and Collection	420
17.5.8 Ethernet Service Rates	425.1 (N)

Advice No. 08-05 Supplement A

Issued February 27, 2008

Effective March 23, 2008

Issued By CENTURYTEL OF WASHINGTON, INC. d/b/a CenturyTel

P.O. Box 9901, Vancouver, WA

By Chantel Mosby

Title Manager, Tariffs and Compliance

WN U-4

CENTURYTEL OF WASHINGTON, INC.

ACCESS SERVICE

TABLE OF CONTENTS (Cont'd)

	<u>Page No.</u>	
18. <u>RATES AND CHARGES</u> For CenturyTel of Washington, Inc.	426	(N)
18.1 <u>Carrier Common Line Access Service</u>	427	
18.2 <u>Access Ordering</u>	427	
18.3 <u>Switched Access Service</u>	428	
18.3.1 Nonrecurring Charges	428	
18.3.2 Local Transport	429	
18.3.3 End Office	433	
18.4 <u>Special Access Service</u>	434	
18.4.1 Nonrecurring Charges	434	
18.4.2 Special Access Surcharge	436	
18.4.3 Special Access Lines	437	
18.4.4 High Capacity Service	439	
18.5 <u>Other Services</u>	442	
18.5.1 Additional Engineering	442	
18.5.2 Additional Labor	443	
18.5.3 Miscellaneous Services	445	
18.5.4 Special Federal Government Access Services	447	
18.5.5 Special Facilities Routing of Access Services	448	
18.5.6 Specialized Service or Arrangements	449	
18.5.7 Billing and Collection	440	
18.5.8 Ethernet Service Rates	454	(N)

Advice No. 08-05

Issued February 22, 2008

Effective March 23, 2008

Issued By CENTURYTEL OF WASHINGTON, INC. d/b/a CenturyTel
P.O. Box 9901, Vancouver, WA

By Chantel Mosby Title Manager, Tariffs and Compliance

WN U-4

First Revised Sheet No. 1
Cancels
Original Sheet No. 1
CENTURYTEL OF WASHINGTON, INC.

(C)

ACCESS SERVICE

CONCURRING CARRIERS

CENTURYTEL OF INTER ISLAND, INC.
dba CENTURYTEL

(C)

(C)

CENTURYTEL OF COWICHE, INC.
dba CENTURYTEL

(C)

(C)

CONNECTING CARRIERS

NO CONNECTING CARRIERS

OTHER PARTICIPATING CARRIERS

NO OTHER PARTICIPATING CARRIERS

REGISTERED SERVICE MARKS

DATAPHONE

REGISTERED TRADEMARKS

DATAPHONE

Advice No. 03-28

Issued July 23, 2003

Effective August 23, 2003

Issued By CENTURYTEL OF WASHINGTON, INC. d/b/a CenturyTel
P.O. Box 9901, Vancouver, WA

(C)

By Pamela Donovan

Title Supervisor, Tariffs

ACCESS SERVICE**EXPLANATION OF SYMBOLS**

- (C) - To signify changed regulation
- (D) - To signify discontinued rate or regulation
- (I) - To signify increase
- (N) - To signify new rate or regulation
- (R) - To signify reduction
- (S) - To signify reissued matter
- (T) - To signify a change in text but no change in rate or regulation
- (M) - To signify material relocated without change
- (Z) - To signify a correction

EXPLANATION OF ABBREVIATIONS

- ac - Alternating current
- AML - Actual Measured Loss
- ANI - Automatic Number Identification
- AP - Program Audio
- AT&T - American Telephone and Telegraph Company
- BD - Business Day
- CNCC - Customer Network Control Center
- COCTX - Central Office Centrex
- Cont'd - Continued
- CPE - Customer Provided Equipment
- CSACC - Customer Service Administration Control Center
- Ctx - Centrex
- DA - Directory Assistance
- db - decibel
- dBrnC - Decibel Reference Noise C-Message Weighted
- dBrnCO - Decibel Reference Noise C-Message Referenced to 0
- dBV - decibel(s) relative to 1 volt (reference)
- dc - direct current
- EDD - Envelope Delay Distortion
- ELEPL - Equal Level Echo Path Loss
- EML - Expected Measured Loss
- EPL - Echo Path Loss
- ERL - Echo Return Loss
- ESS - Electronic Switching System
- ESSX - Electronic Switching System Exchange
- f - frequency
- FI - Facility Interface
- FID - Field Identifier
- F.C.C. - Federal Communications Commission
- FX - Foreign Exchange

Advice No. 03-28

Issued July 23, 2003

Effective August 23, 2003

Issued By CENTURYTEL OF WASHINGTON, INC. d/b/a CenturyTel

(C)

P.O. Box 9901, Vancouver, WA

By Pamela Donovan

Title Supervisor, Tariffs

ACCESS SERVICE

EXPLANATION OF SYMBOLS (Cont'd)

HC - High Capacity
 Hz - Hertz
 IC - Interexchange or Intraexchange Customer
 ICB - Individual Case Basis
 ICL - Inserted Connection Loss
 IXC - Interexchange Channel
 kbps - kilobits per second
 kHz - kilohertz
 LATA - Local Access and Transport Area
 LDMTS - Long Distance Message Telecommunications Service(s)
 Ma - milliamperes
 Mbps - Megabits per second
 MHz - Megahertz
 MMUC - Monthly Recurring Charge
 MRC - Monthly Recurring Charge
 NB - Narrowband
 NPA - Numbering Plan Area
 NRC - Nonrecurring Charge
 NTS - Non-Traffic Sensitive
 NXX - Three Digit Central Office Code
 OMF - Optional Miscellaneous Functions
 OTPL - Zero Transmission Level Point
 PBX - Private Branch Exchange
 PCM - Pulse Code Modulation
 PLR - Private Line Ringdown
 POI - Point of Interface
 rms - root-mean-square
 RMS - Remote Switching Modules
 RSS - Remote Switching Systems
 SRL - Singing Return Loss
 SSN - Switched Service Network
 SWC - Serving Wire Center
 TES - Telephone Exchange Service(s)
 TLP - Transmission Level Point
 TSPS - Traffic Service Position System
 TV - Television
 USOC - Uniform Service Order Code
 VG - Voice Grade
 V & H - Vertical & Horizontal
 WA - Wideband Analog
 WATS - Wide Area Telecommunications Service(s)
 WD - Wideband Digital

Advice No. 03-28

Issued July 23, 2003

Effective August 23, 2003

Issued By CENTURYTEL OF WASHINGTON, INC. d/b/a CenturyTel

P.O. Box 9901, Vancouver, WA

(C)

By Pamela Donovan

Title Supervisor, Tariffs

WN U-4

First Revised Sheet No. 6
Cancels
Original Sheet No. 6
CENTURYTEL OF WASHINGTON, INC.

(C)

ACCESS SERVICE

REFERENCE TO TECHNICAL PUBLICATIONS (Cont'd)

The following technical publication is referenced in this tariff and may be obtained from the National Exchange Carrier Association, Inc., Director-Tariff and Regulatory Matters, 100 So. Jefferson Road, Whippany, N.J. 07981 and the Federal Communications Commission's Commercial Contractor

PUB AS No. 1, Issue II
Issued: March 2, 1987 May, 1984 Available: May, 1984

Advice No. 03-28

Issued July 23, 2003 Effective August 23, 2003
Issued By CENTURYTEL OF WASHINGTON, INC. d/b/a CenturyTel
 P.O. Box 9901, Vancouver, WA
By Pamela Donovan Title Supervisor, Tariffs

(C)

ACCESS SERVICE

1. Application of Tariff

- 1.1 This tariff contains regulations, rates and charges applicable to the provision of Carrier Common Line, End User Access, Switched Access and Special Access Services, and other miscellaneous services, hereinafter referred to collectively as service(s), provided by the issuing carriers of this tariff, hereinafter referred to as the Telephone Company, to Customer(s).
- 1.2 The provision of such service by the Telephone Company as set forth in this tariff is specifically intended to provide exchange network access to customers as follows:
- (a) Interexchange Carriers, including Telecommunications Companies as defined in RCW 80.04.010, who provide service between Local Calling Areas, must purchase services from this tariff for their use in furnishing their authorized intrastate telecommunications services to end user customers, and for operational purposes directly related to the furnishing of such services;
- (b) Any customer, including but not limited to, Telecommunications Companies and/or Interexchange Carriers, may purchase certain services from this tariff for their own administrative use, as specified in other sections of this tariff. Services provided for a customer's own or administrative use may be subject to the rates and charges of other tariffs of the Telephone Company.
- 1.3 The provision of such services by the Telephone Company as set forth in this tariff does not constitute a joint undertaking with the customer the furnishing of any service.
- 1.4 The regulations, rates and charges for access service are contained herein. All rates and charges are expressed in U.S. Dollars.
- 1.5 All rates and charges set forth in this tariff provide for the furnishing of service where suitable facilities are available, and for installation in normal locations under normal working conditions, as determined by the Telephone Company. When special construction of access facilities is involved or when expedited or other abnormal installation is required, additional charges may apply and such charges based on the estimated costs associated with such special construction or installation will be developed as occasion requires. Special construction is involved when, at the request of a customer or group of customer's, the Telephone Company constructs access facilities in order to provide service, and conditions, such as one or more of the following are present:

Advice No. 03-28

Issued July 23, 2003

Effective August 23, 2003

Issued By CENTURYTEL OF WASHINGTON, INC. d/b/a CenturyTel
P.O. Box 9901, Vancouver, WA

(C)

By Pamela Donovan Title Supervisor, Tariffs

ACCESS SERVICE

1 Application of Tariff (Continued)

1.5 (Continued)

- (a) There is no requirement for the facilities so constructed, other than to furnish the requested service.
- (b) The facilities are of a type, or over a routing, other than that which the Telephone Company would normally utilize.
- (c) The Telephone Company constructs a greater quantity of facilities than it would otherwise construct in order to fulfill the initial requirements of service.
- (d) The Telephone Company expedites construction at greater expense than would otherwise be incurred.
- (e) The Telephone Company constructs temporary facilities to provide service for the period during which permanent facilities are under construction.

Special construction, when ordered by the customer will be provided and filed in this tariff on an Individual case basis (ICB).

Advice No. 03-28

Issued July 23, 2003

Effective August 23, 2003

Issued By CENTURYTEL OF WASHINGTON, INC. d/b/a CenturyTel
P.O. Box 9901, Vancouver, WA

By Pamela Donovan

Title Supervisor, Tariffs

(C)

ACCESS SERVICE

2. General Regulations (Cont'd)

2.1 Undertaking of the Telephone Company (Cont'd)

2.1.2 Limitations (Cont'd)

(C) Subject to compliance with the rules mentioned in (B) preceding, the services offered herein will be provided to customers on a first-come, first-served basis.

2.1.3 Liability

(A) Except as set forth in 8.1.3 following, the Telephone Company's liability, if any, for its willful misconduct is not limited by this tariff. With respect to any other claim or suit, a customer or by any others, for damages associated with the installation, provision, termination, maintenance, repair or restoration of service, and subject to the provisions of (B) through (H) following, the Telephone Company's liability, if any, shall not exceed an amount equal to the proportionate charge for the service for the period during which the service was affected. This liability for damages shall be in addition to any amounts that may otherwise be due the customer under this tariff as a Credit Allowance for a Service Interruption.

(B) The Telephone Company shall not be liable for any act or omission of any other carrier or customer providing a portion of a service, nor shall the Telephone Company for its own actor omission hold liable any other carrier or customer providing a portion of a service.

(C)

(D) The Telephone Company is not liable for damages to the customer premises resulting from the furnishing of a service, including the installation and removal of equipment and associated wiring, unless the damage is caused by the Telephone Company's negligence.

(E) The Telephone Company shall be indemnified, defended and held harmless by the Customer and/or the End User against any claim, loss or damage arising from the End User's use of services offered under this tariff, involving:

Advice No. 03-28

Issued July 23, 2003

Effective August 23, 2003

Issued By CENTURYTEL OF WASHINGTON, INC. d/b/a CenturyTel

P.O. Box 9901, Vancouver, WA

(C)

By Pamela Donovan

Title Supervisor, Tariffs

ACCESS SERVICE

2. General Regulations (Cont'd)

2.1 Undertaking of the Telephone Company (Cont'd)

2.1.3 Liability (Cont'd)

(E) Cont'd)

- (1) Claims for libel, slander, invasion of privacy, or infringement of copyright arising from the End User's own communications;
 - (2) Claims for patent infringement arising from the End User's acts combining or using the service furnished by the Telephone Company in connection with facilities or equipment furnished by the End User or IC or;
 - (3) All other claims arising out of any act or omission of the End User in the course of using services provided pursuant to this tariff.
- (F) The Telephone Company does not guarantee or make any warranty with respect to its services when used in an explosive atmosphere. The Telephone Company shall be indemnified, defended and held harmless by the customer and/or end user from any and all claims by any person relating to such customer's use of services so provided.
- (G) No license under patents (other than the limited license to use) is granted by the Telephone Company or shall be implied or arise by estoppel, with respect to any service offered under this tariff. The Telephone Company will defend the customer and/or end user against claims of patent infringement arising solely from the use by the customer of services offered under this tariff and will indemnify such for any damages awarded based solely on such claims.
- (H) The Telephone Company's failure to provide or maintain services under this tariff shall be excused by labor difficulties, governmental orders, civil commotions, criminal actions taken against the Telephone Company, acts of God and other circumstances beyond the Telephone Company's reasonable control, subject to the Credit Allowance for a Service Interruption as set forth in 2.4.4 following.

Advice No. 03-28

Issued July 23, 2003

Effective August 23, 2003

Issued By CENTURYTEL OF WASHINGTON, INC. d/b/a CenturyTel
P.O. Box 9901, Vancouver, WA

(C)

By Pamela Donovan Title Supervisor, Tariffs

ACCESS SERVICE

2. General Regulations (Cont'd)

2.1 Undertaking of the Telephone Company (Cont'd)

2.1.4 Provision of Services

The Telephone Company, to the extent that such services are or can be made available with reasonable effort, and after provision has been made for the Telephone Company's telephone exchange services, will provide to the customer upon reasonable notice services offered in other applicable sections of this tariff at rates and charges specified therein.

2.1.5 Installation and Termination of Services

The services provided under this tariff (A) will include any entrance cable or drop wiring and wire or intrabuilding network cable to that point where provision is made for termination of the Telephone Company's outside distribution network facilities at a suitable location inside a customer-designated premises and (B) will be installed by the Telephone Company to such Point of Termination. Wire required within a building to extend Access Service facilities will be provided, at the customer's request, on a time sensitive charge basis. The labor rates for the installation of such wire are the same as those set forth in 13.2.6(C) following for Other Labor.

2.1.6 Maintenance of Services

The services provided under this tariff shall be maintained by the Telephone Company. The customer or others may not rearrange, move, disconnect, remove or attempt to repair any facilities provided by the Telephone Company except with the written consent of the Telephone Company. The customer shall maintain all facilities provided by it. The Telephone Company shall not be responsible to customers for end-to-end service of which the services provided under this tariff are part.

2.1.7 Changes and Substitutions

Except as provided for equipment and systems subject to FCC Part 68 regulations at 47 C.F.R. § 68.110 b., the Telephone Company may, where such action is reasonably required in the operation of its business, (A) substitute, change or rearrange any facilities used in providing service under this tariff, including but not limited to, (1) substitution of different metallic facilities, (2) substitution of carrier or derived facilities for metallic facilities used to provide other than metallic facilities and (3) substitution of metallic facilities for carrier or derived facilities used to provide other than

Advice No. 03-28

Issued July 23, 2003

Effective August 23, 2003

Issued By CENTURYTEL OF WASHINGTON, INC. d/b/a CenturyTel
P.O. Box 9901, Vancouver, WA

(C)

By Pamela Donovan Title Supervisor, Tariffs

ACCESS SERVICE

2. General Regulations (Cont'd)

2.1 Undertaking of the Telephone Company (Cont'd)

2.1.7 Changes and Substitutions (Cont'd)

(B) metallic facilities change minimum protection criteria, (C) change operating or maintenance characteristics of facilities or (D) change operations or procedures of the Telephone Company. In case of any such substitution, change or rearrangement, the transmission parameters will be within the range as set forth in 6. and 7. following. The Telephone Company shall not be responsible if any such substitution, change or rearrangement renders any customer furnished services obsolete or requires modification or alteration thereof or otherwise affects their use or performance. If such substitution, change or rearrangement materially affects the operating characteristics of the facility, the Telephone Company will provide reasonable notification to the customer in writing. Reasonable time will be allowed for any redesign and implementation required by the change in operating characteristics. The Telephone Company will work cooperatively with the customer to determine reasonable notification procedures.

2.1.8 Refusal and Discontinuance of Services

(A) Unless the provisions of 2.2.2 (B) or 2.5 following apply, if a customer fails to comply with 2.1.6 preceding or 2.2.3, 2.3.1, 2.3.6, 2.3.7 or 2.4 following, including any payments to be made by it on the dates and times herein specified, the Telephone Company may, on thirty (30) day's written notice by Certified U.S. Mail to the person designated by the customer to receive such notices of non-compliance, refuse additional applications for service and/or refuse to complete any pending orders for service by the non-complying customer at any time thereafter. If the Telephone Company does not refuse additional applications for service on the date specified in the thirty (30) days notice, and the customer's noncompliance continues, nothing contained herein shall preclude the Telephone Company's right to refuse additional applications for service to the non-complying customer without further notice.

Advice No. 03-28

Issued July 23, 2003

Effective August 23, 2003

Issued By CENTURYTEL OF WASHINGTON, INC. d/b/a CenturyTel
P.O. Box 9901, Vancouver, WA

(C)

By Pamela Donovan

Title Supervisor, Tariffs

ACCESS SERVICE

2. General Regulations (Cont'd)

2.1 Undertaking of the Telephone Company (Cont'd)

2.1.8 Refusal and Discontinuance of Services (Cont'd)

- (B) Unless the provisions of 2.2.2(B) or 2.5 following apply, if a customer fails to comply with 2.1.6 preceding or 2.2.3, 2.3.1, 2.3.6, 2.3.7 or 2.4 following, including any payments to be made by it on the dates and times specified, the Telephone Company may, on an additional thirty (30) day's written notice by Certified U.S. Mail to the person designated by that customer to receive such notices of noncompliance, discontinue the provision of the services to the non-complying customer at any time thereafter. In the case of such discontinuance, all applicable charges shall become due. If the Telephone Company does not discontinue the provision of the services involved on the date specified in the thirty (30) day's notice, and the customer's noncompliance continues, nothing contained herein shall preclude the Telephone Company's right to discontinue the provision of the services to the non-complying customer without further notice.
- (C) The Telephone Company shall deny service to a nonregistered telecommunications company that intends to use the service to provide telecommunications for hire, sale, or resale to the general public within the state of Washington. Any telecommunications company requesting service from a local exchange company shall state in writing whether the service is intended to be used for intrastate telecommunications for hire, sale, or resale to the general public.

Advice No. 03-28

Issued July 23, 2003

Effective August 23, 2003

Issued By CENTURYTEL OF WASHINGTON, INC. d/b/a CenturyTel
P.O. Box 9901, Vancouver, WA

(C)

By Pamela Donovan Title Supervisor, Tariffs

ACCESS SERVICE

2 General Regulations (Cont'd)

2.1 Undertaking of the Telephone Company (Cont'd)

2.1.9

2.1.10 Limitation of Use of Metallic Facilities

Signals applied to a metallic facility shall conform to the limitations set forth in Technical Reference Publication AS No.1. In the case of application of dc telegraph signaling systems, the customer shall be responsible, at its expense, for the provision of current limiting devices to protect the Telephone Company facilities from excessive current due to abnormal conditions and for the provision of noise mitigation networks when required to reduce excessive noise.

2.1.11 Notification of Service-Affecting Activities

The Telephone Company will provide the customer reasonable notification of service-affecting activities that may occur in normal operation of its business. Such activities may include, but are not limited to, equipment or facility additions, removals or rearrangements, routine preventative maintenance and major switching machine change-out. Generally, such activities are not individual customer specific, they affect many customer services. No specific advance notification period is applicable to all service activities. The Telephone Company will work cooperatively with the customer to determine the notification requirements.

2.1.12 Coordination with Respect to Network Contingencies

The Telephone Company intends to work cooperatively with the customer to develop network contingency plans in order to maintain maximum network capability following natural or man-made disasters which affect telecommunications services.

Advice No. 03-28

Issued July 23, 2003

Effective August 23, 2003

Issued By CENTURYTEL OF WASHINGTON, INC. d/b/a CenturyTel
P.O. Box 9901, Vancouver, WA

(C)

By Pamela Donovan Title Supervisor, Tariffs

ACCESS SERVICE

2. General Regulations (Cont'd)

2.1 Undertaking of the Telephone Company (Cont'd)

2.1.13 Provision and Ownership of Telephone Numbers

The Telephone Company reserves the reasonable right to assign, designate or change telephone numbers, any other call number designations associated with Access Services, or the Telephone Company serving central office prefixes associated with such numbers, when necessary in the conduct of its business. Should it become necessary to make a change in such number(s), the Telephone Company will furnish to the customer reasonable notice, by certified U.S. Mail, of the effective date and an explanation of the reason(s) for such change(s).

2.1.14 Warrant of Facilities and Services

The Telephone Company does not warrant that its facilities and services meet standards other than those set forth in this tariff.

2.2 Use

2.2.1

2.2.2 Interference or Impairment

(A) The characteristics and methods of operation of any circuits, facilities or equipment provided by other than the Telephone Company and associated with the facilities utilized to provide services under this tariff shall not interfere with or impair service over any facilities of the Telephone Company, its affiliated companies, or its connecting and concurring carriers involved in its services, cause damage to their plant, impair the privacy of any communications carried over their facilities or create hazards to the employees of any of them or the public.

Advice No. 03-28

Issued July 23, 2003

Effective August 23, 2003

Issued By CENTURYTEL OF WASHINGTON, INC. d/b/a CenturyTel

P.O. Box 9901, Vancouver, WA

(C)

By Pamela Donovan

Title Supervisor, Tariffs

ACCESS SERVICE

2. General Regulations (Cont'd)

2.2 Use (Cont'd)

2.2.2 Interference or Impairment (Cont'd)

- (B) Except as provided for equipment or systems subject to the FCC Part 68 rules in 47 C.F.R. § 68.108, if such characteristics or methods of operation are not in accordance with (A) preceding, the Telephone Company will, where practicable, notify the customer that temporary discontinuance of the use of a service may be required; however, where prior notice is not practicable, nothing contained herein shall be deemed to preclude the Telephone Company's right to temporarily discontinue forthwith the use of a service if such action is reasonable under the circumstances. In case of such temporary discontinuance, the customer will be promptly notified and afforded the opportunity to correct the condition which gave rise to the temporary discontinuance. During such period of temporary discontinuance, credit allowance for service interruptions as set forth in 2.4.4 following is not applicable.

2.2.3 Unlawful Use

The service provided under this tariff shall not be used for an unlawful purpose.

Advice No. 03-28

Issued July 23, 2003

Effective August 23, 2003

Issued By CENTURYTEL OF WASHINGTON, INC. d/b/a CenturyTel

P.O. Box 9901, Vancouver, WA

(C)

By Pamela Donovan

Title Supervisor, Tariffs

ACCESS SERVICE

2. General Regulations (Cont'd)

2.3 Obligations of the Customer

2.3.1 Damages

The customer shall reimburse the Telephone Company for damages to Telephone Company facilities utilized to provide services under this tariff caused by the negligence or willful act of the customer or resulting from the customer's improper use of the Telephone Company facilities, or due to malfunction of any facilities or equipment provided by other than the Telephone Company. Nothing in the foregoing provision shall be interpreted to hold one customer liable for another customer's actions. The Telephone Company will, upon reimbursement for damages, cooperate with the customer in prosecuting a claim against the person causing such damage and the customer shall be subrogated to the right of recovery by the Telephone Company for the damages to the extent of such payment.

2.3.2 Ownership of Facilities and Theft

Facilities utilized by the Telephone Company to provide service under the provisions of this tariff shall remain the property of the Telephone Company. Such facilities shall be returned to the Telephone Company by the customer, whenever requested, within a reasonable period following the request in as good condition as reasonable wear will permit.

2.3.3 Equipment Space and Power

The customer shall furnish or arrange to have furnished to the Telephone Company, at no charge, equipment space and electrical power required by the Telephone Company to provide services under this tariff at the points of termination of such services. The selection of ac or dc power shall be mutually agreed to by the customer and the Telephone Company. The customer shall also make necessary arrangements in order that the Telephone Company will have access to such spaces at reasonable times for installing, testing, repairing or removing Telephone Company services.

Advice No. 03-28

Issued July 23, 2003

Effective August 23, 2003

Issued By CENTURYTEL OF WASHINGTON, INC. d/b/a CenturyTel
P.O. Box 9901, Vancouver, WA

(C)

By Pamela Donovan

Title Supervisor, Tariffs

ACCESS SERVICE

2. General Regulations (Cont'd)

2.3 Obligations of the Customer (Cont'd)

2.3.4

2.3.5

2.3.6 Availability for Testing

The services provided under this tariff shall be available to the Telephone Company at times mutually agreed upon in order to permit the Telephone Company to make tests and adjustments appropriate for maintaining the services in satisfactory operating condition. Such tests and adjustments shall be completed within a reasonable time. No credit will be allowed for any interruptions involved during such tests and adjustments.

2.3.7 Balance

All signals for transmission over the services provided under this tariff shall be delivered by the customer balanced to ground except for ground start, duplex (DX) and McCulloh-Loop (Alarm System) type signaling and dc telegraph transmission at speeds of 75 baud or less.

Advice No. 03-28

Issued July 23, 2003

Effective August 23, 2003

Issued By CENTURYTEL OF WASHINGTON, INC. d/b/a CenturyTel
P.O. Box 9901, Vancouver, WA

(C)

By Pamela Donovan

Title Supervisor, Tariffs

ACCESS SERVICE

2. General Regulations (Cont'd)

2.3 Obligations of the Customer (Cont'd)

2.3.8 Design of Customer Services

Subject to the provisions of 2.1.7 preceding, each customer shall be responsible, at its own expense, for the overall design of its services and for any redesigning or rearrangement of its services which may be required because of changes in facilities, operations or procedures of the Telephone Company, minimum protection criteria or operating or maintenance characteristics of the facilities.

2.3.9 References to the Telephone Company

The customer may advise End Users that certain services are provided by the Telephone Company in connection with the service the customer furnishes to End Users; however, the customer shall not represent that the Telephone Company jointly participates in the customer's services.

2.3.10

2.3.11 Claims and Demands for Damages

- (A) With respect to claims of patent infringement made by third persons, the customer shall defend, indemnify, protect and save harmless the Telephone Company from and against all claims arising out of the combining with, or use in connection with, the services provided under this tariff, any circuit, apparatus, system or method provided by the customer or End User.
- (B) The customer shall defend, indemnify and save harmless the Telephone Company from and against suits, claims, losses or damages, including punitive damages, attorney fees and court costs by third persons arising out of the construction, installation, operation, maintenance, or removal of the customer's circuits, facilities, or equipment connected to the

Advice No. 03-28

Issued July 23, 2003

Effective August 23, 2003

Issued By CENTURYTEL OF WASHINGTON, INC. d/b/a CenturyTel

P.O. Box 9901, Vancouver, WA

(C)

By Pamela Donovan

Title Supervisor, Tariffs

ACCESS SERVICE2. General Regulations (Cont'd)2.3 Obligations of the Customer (Cont'd)2.3.11 Claims and Demands for Damages (Cont'd)

(B) (Cont'd)

Telephone Company's services provided under this tariff, including, without limitation, Workmen's Compensation claims, actions for infringement of copyright and/or unauthorized use of program material, libel and slander actions based on the content of communications transmitted over the customer's circuits, facilities or equipment, and proceedings to recover taxes, fines, or penalties for failure of the customer to obtain or maintain in effect any necessary certificates, permits, licenses, or other authority to acquire or operate the services provided under this tariff; provided, however, the foregoing indemnification shall not apply to suits, claims, and demands to recover damages for damage to property, death, or personal injury unless such suits, claims or demands are based on the tortious conduct of the customer, its officers, agents or employees.

(C) The customer shall defend, indemnify and save harmless the Telephone Company from and against any suits, claims, losses or damages, including punitive damages, attorney fees and court costs by the customer or third parties arising out of any act or omission of the customer in the course of using services provided under this tariff.

2.3.12

Advice No. 03-28

Issued July 23, 2003

Effective August 23, 2003

Issued By CENTURYTEL OF WASHINGTON, INC. d/b/a CenturyTel
P.O. Box 9901, Vancouver, WA

(C)

By Pamela Donovan

Title Supervisor, Tariffs

ACCESS SERVICE

2. General Regulations (Cont'd)

2.3 Obligations of the Customer (Cont'd)

2.3.13 Coordination with Respect to Network Contingencies

The customer shall, in cooperation with the Telephone Company, coordinate in planning the actions to be taken to maintain maximum network capability following natural or man-made disasters which affect telecommunications services.

2.3.14 Jurisdictional Report Requirements

(A) Jurisdictional Reports

- (1) When a customer orders equivalent Feature Group A and/or Feature Group B Switched Access Service, the customer shall, in its order, state the number of Feature Group A and/or Feature Group B Switched Access Service(s) which are to be provided for intrastate use. The number shall be stated as the number of whole lines for Feature Group A Switched Access Service and the number of whole trunks for Feature Group B Switched Access Service.
- (2) Except as provided in (4) following, all Feature Group A and/or Feature Group B Switched Access Services ordered under this tariff not provided in a multiline hunt group or trunk group arrangement are designated as intrastate service.
- (3) For purposes of determining the jurisdiction of FGA and FGB switched access traffic provided in a multiline hunt group, the customer shall estimate the percent of interstate and intrastate access minutes based on the following criteria:
 - (a) Traffic that enters a customer's network within the same state as that in which the station designated by dialing is situated will be considered intrastate.
 - (b) Traffic that enters a customer's network within a state other than that in which the station designated by dialing is situated will be considered interstate.

Advice No. 03-28

Issued July 23, 2003

Effective August 23, 2003

Issued By CENTURYTEL OF WASHINGTON, INC. d/b/a CenturyTel
P.O. Box 9901, Vancouver, WA

(C)

By Pamela Donovan Title Supervisor, Tariffs

ACCESS SERVICE

2. General Regulations (Cont'd)

2.3 Obligations of the Customer (Cont'd)

2.3.14 Jurisdictional Report Requirements (Cont'd)

(A) Jurisdictional Reports (Cont'd)

(4) For multiline hunt group or trunk group arrangements where either the intrastate or the intrastate charges are based on measured usage, the intrastate Feature Group A and/or Feature Group B Switched Access Service(s) reported as set forth in (1) preceding will be used to determine the charges as follows:

- (a) For a group where the intrastate charges are per month charges, the number of access minutes for a group will be multiplied by the number of interstate lines or trunks for the group (the total number of lines or trunks in the group minus the reported intrastate lines or trunks) and divided by the total number of lines or trunks for the group to determine intrastate access minutes. For example, if a customer orders a group with 10 Feature Group A Switched Access Services and reports 7 Feature Group A as intrastate (then 3 Feature Group A services would be interstate lines), $(10-7)/10$ or 30% of the total access minutes for the group would be interstate access minutes. The number of intrastate lines or trunks reported for the group (7 lines using the example above) will be billed as set forth in 6. following.
- (b) For a group where the intrastate charges are per minute charges, the number of access minutes for a group will be multiplied by the appropriate percentages as estimated by the customer pursuant to (2) preceding to determine the interstate and intrastate access minutes. The developed intrastate access minutes for the group will be billed in accordance with Section 6. following.

Advice No. 03-28

Issued July 23, 2003

Effective August 23, 2003

Issued By CENTURYTEL OF WASHINGTON, INC. d/b/a CenturyTel
P.O. Box 9901, Vancouver, WA

(C)

By Pamela Donovan Title Supervisor, Tariffs

ACCESS SERVICE2. General Regulations (Cont'd)2.3 Obligations of the Customer (Cont'd)2.3.14 Jurisdictional Report Requirements (Cont'd)(A) Jurisdictional Reports (Cont'd)

- (5) When a customer orders Feature Group C or Feature Group D Switched Access Service(s), the Telephone Company, where the jurisdiction can be determined from the call detail, will, unless the customer provides the projected intrastate percentage for intrastate usage for each end office group in its order, determine the projected intrastate percentage as follows. For originating access minutes, the projected intrastate percentage will be developed on a monthly basis by end office when the Feature Group C or Feature Group D Switched Access Service access minutes are measured by dividing the measured intrastate originating access minutes by the total originating access minutes when the call detail is adequate to determine the appropriate jurisdiction. For terminating access minutes, the data used by the Telephone Company to develop the projected intrastate percentage for originating access minutes will be used to develop projected intrastate percentage for such terminating access minutes. When originating call details are insufficient to determine the jurisdiction for the call, the customer shall supply the projected intrastate percentage or authorize the Telephone Company to develop percentages based on the most recent available call detail. This percentage shall be used by the Telephone Company as the intrastate percentage for such call detail. The Telephone Company will designate the number obtained by subtracting the projected intrastate percentage for originating and terminating access minutes calculated by the Telephone Company from 100 (100 - Telephone Company calculated projected intrastate percentage = interstate percentage) as the projected interstate percentage of use.

Advice No. 03-28

Issued July 23, 2003

Effective August 23, 2003

Issued By CENTURYTEL OF WASHINGTON, INC. d/b/a CenturyTel
P.O. Box 9901, Vancouver, WA

(C)

By Pamela Donovan Title Supervisor, Tariffs

ACCESS SERVICE

2. General Regulations (Cont'd)

2.3 Obligations of the Customer (Cont'd)

2.3.14 Jurisdictional Report Requirements (Cont'd)

(A) Jurisdictional Reports (Cont'd)

- (6) When a customer orders Directory Assistance Service, the customer shall in its order, provide the projected intrastate percentage for terminating use in a whole number (a number of 0 through 100) for each Directory Access Service group ordered. (A method the customer may wish to adopt could be to use its terminating traffic from its premises to the involved Directory Assistance location and calculate the projected intrastate percentage as set forth in (4) preceding.) The Telephone Company will designate the number obtained by subtracting the projected intrastate percentage furnished by the customer from 100 (100 - customer percentage = interstate percentage) as the projected interstate percentage of use.
- (7) Except where Telephone Company measured access minutes are used as set forth in (5) preceding, the customer reported number of intrastate services or intrastate percentage of use as set forth in (1), (4), (5) or (6) preceding will be used until the customer reports a different number of lines or trunks, or a different percentage, for interstate use in accordance with paragraph (8) following. The revised report will serve as the basis for future billing and will be effective on the next bill date. No prorating or back billing will be done based on the report.

Advice No. 03-28

Issued July 23, 2003

Effective August 23, 2003

Issued By CENTURYTEL OF WASHINGTON, INC. d/b/a CenturyTel
P.O. Box 9901, Vancouver, WA

(C)

By Pamela Donovan Title Supervisor, Tariffs

ACCESS SERVICE

2. General Regulations (Cont'd)2.3 Obligations of the Customer (Cont'd)2.3.14 Jurisdictional Report Requirements (Cont'd)(A) Jurisdictional Reports (Cont'd)

- (8) If the customer provides jurisdictional information, the following requirements apply:
- (a) The customer will provide quarterly reports indicating the percent of total Telephone Company provided Switched Access usage that is interstate and intrastate. The reports may aggregate usage at a statewide level or below.
 - (b) The reports will be based on the calendar year and will be due within fifteen days after the end of the quarter beginning with the completion of the first full quarter of service.
 - (c) The customer will maintain records of call detail from which the jurisdictional determination is made and make these records available for inspection on an annual basis by the Telephone Company at a time mutually agreeable to the Telephone Company and the customer.

Advice No. 03-28

Issued July 23, 2003

Effective August 23, 2003

Issued By CENTURYTEL OF WASHINGTON, INC. d/b/a CenturyTel
P.O. Box 9901, Vancouver, WA

(C)

By Pamela Donovan Title Supervisor, Tariffs

ACCESS SERVICE

2. General Regulations (Cont'd)

2.4 Payment Arrangements and Credit Allowances

2.4.1 Payment of Rates, Charges and Deposits

- (A) The Telephone Company will, in order to safeguard its interests, only require a customer which has a proven history of late payments to the Telephone Company or does not have established credit to make a deposit prior to or at any time after the provision of a service to the customer to be held by the Telephone Company as a guarantee of the payment of rates and charges. No such deposit will be required of a customer which is a successor of a company which has established credit and has no history of late payments to the Telephone Company. When a deposit is required, such deposit shall be equal to two months of estimated billings. If past service has been provided, the estimated billing shall be calculated based upon the average monthly billings over the past three months. Such a calculation is subject to revision based upon changes in the average of the past months' billings. At such time as the provision of the service to the customer is terminated, the amount of the deposit will be credited to the customer's account and any credit balance which may remain will be refunded. Such a deposit will be refunded or credited, in any event, to the customer's account when the customer has established credit or will be refunded when the customer has established a one-year prompt payment at any time prior to the termination of the provision of the service to the customer. In case of a cash deposit, for the period the deposit is held by the Telephone Company, the customer will receive interest at the lawful rate as specified by WAC 480-120-056, sub paragraph 5 or 7 percent simple interest per annum if no rate is specified. The rate will be applied for the number of days from the date the customer deposit is received by the Telephone Company to and including the date such deposit is credited to the customer's account or the date the deposit is refunded by the Telephone Company. Should a deposit be credited to the customer's account, as indicated above, no interest will accrue on the deposit from the date such deposit is credited to the customer's account.

Advice No. 03-28

Issued July 23, 2003

Effective August 23, 2003

Issued By CENTURYTEL OF WASHINGTON, INC. d/b/a CenturyTel
P.O. Box 9901, Vancouver, WA

(C)

By Pamela Donovan Title Supervisor, Tariffs

ACCESS SERVICE

2. General Regulations (Cont'd)

2.4 Payment Arrangements and Credit Allowances (Cont'd)

2.4.1 Payment of Rates, Charges and Deposits (Cont'd)

(B) (Cont'd)

(3)

- (a) All bills dated as set forth in (2) preceding for service, other than End User Service provided to the customer by the Telephone Company, are due 31 days (payment date) after the bill day or by the next bill date (i.e., same date in the following month as the bill date) whichever is the shortest interval, except as provided herein. If the customer does not receive a bill at least 20 days prior to the 31 day payment due date, then the bill shall be considered delayed. When the bill has been delayed upon the request of the customer the due date will be extended by the number of days the bill was delayed. Such request of the customer must be accompanied with proof of late bill receipt.

If such payment would cause payment to be due on a Saturday, Sunday or Legal Holiday, payment for such bills will be due from the customer as follows: - If the payment date falls on a Sunday or on a Legal Holiday which is observed on a Monday, the payment date shall be the first non-Holiday day following such Sunday or Legal Holiday. - If the payment date falls on a Saturday or on a Legal Holiday which is observed on Tuesday, Wednesday, Thursday or Friday, the payment date shall be the last non-Holiday day preceding such Saturday or Legal Holiday.

Advice No. 03-28

Issued July 23, 2003

Effective August 23, 2003

Issued By CENTURYTEL OF WASHINGTON, INC. d/b/a CenturyTel
P.O. Box 9901, Vancouver, WA

(C)

By Pamela Donovan Title Supervisor, Tariffs

ACCESS SERVICE

2. General Regulations (Cont'd)

2.4 Payment Arrangements and Credit Allowances (Cont'd)

2.4.1 Payment of Rates, Charges and Deposits (Cont'd)

(B) (Cont'd)

(3) (Cont'd)

(b) Further, if no payment is received by the payment date or if a payment or any portion of a payment is received by the Telephone Company after the payment date as set forth in (a) preceding, or if a payment or any portion of a payment is received by the Telephone Company in funds which are not immediately available to the Telephone Company, then a late payment penalty shall be due to the Telephone Company. The late payment penalty shall be the portion of the payment not received by the payment date times a late factor. The late factor shall be the lessor of:

- (i) The highest interest rate (in decimal value) which may be levied by law for commercial transactions, compounded daily for the number of days from the payment date to and including the date that the customer actually makes the payment to the Telephone Company, or
- (ii) 0.000407 per day, compounded daily for the number of days from the payment date to and including the date that the customer actually makes payment to the Telephone Company.

Advice No. 03-28

Issued July 23, 2003

Effective August 23, 2003

Issued By CENTURYTEL OF WASHINGTON, INC. d/b/a CenturyTel

P.O. Box 9901, Vancouver, WA

(C)

By Pamela Donovan

Title Supervisor, Tariffs

ACCESS SERVICE

2. General Regulations (Cont'd)

2.4 Payment Arrangements and Credit Allowances (Cont'd)

2.4.1 Payment of Rates, Charges and Deposits (Cont'd)

- (C) When a payment for Access Service Charges billed under this Tariff is due to the Telephone Company from the customer as set forth in (B)(3) preceding on the same payment date that a Purchase of Accounts Receivable net purchase amount is due to the customer from the Telephone Company as set forth in 8.2.3 following, the Telephone Company may, with a least 31 days notice to the customer, net the payment for customer Access Service Charges with the net purchase amount. The Telephone Company will pay the net amount to the customer in funds which are immediately available on the payment date when such net amount is due to the customer or require the customer to pay to the Telephone Company in funds which are immediately available, the net amount when such net amount is due to the Telephone Company.
- (D) Adjustments for the quantities of services established or discontinued in any billing period beyond the minimum period set forth for services in other sections of this tariff will be prorated to the number of days or major fraction of days based on a 30 day month. The Telephone Company will, upon request and if available, furnish such detailed information as may reasonably be required for verification of any bill.
- (E) When a rate as set forth in this tariff is shown to more than two decimal places, the charges will be determined using the rate shown. The resulting amount will then be rounded to the nearest penny (i.e., rounded to two decimal places).
- (F) When more than one copy of a customer bill for services provided under the provisions of this tariff is furnished to the customer, an additional charge applies for each additional copy of the bill as set forth in 13.3.6 following.

Advice No. 03-28

Issued July 23, 2003

Effective August 23, 2003

Issued By CENTURYTEL OF WASHINGTON, INC. d/b/a CenturyTel
P.O. Box 9901, Vancouver, WA

(C)

By Pamela Donovan Title Supervisor, Tariffs

ACCESS SERVICE

2. General Regulations (Cont'd)
2.4 Payment Arrangements and Credit Allowances (Cont'd)
2.4.3 Cancellation of an Order for Service

Provisions for the cancellation of an order for service are set forth in other applicable sections of this tariff.

2.4.4 Credit Allowance for Service Interruptions

(A) General

A service is interrupted when it becomes unusable to the customer because of a failure of a facility component used to furnish service under this tariff or in the event that the protective controls applied by the Telephone Company result in a complete loss of service by the customer as set forth in 6.5.1 following. An interruption period starts when the Telephone Company becomes aware of an inoperative service, regardless of when it receives a specific customer report, and ends when the service is operative.

(B) When a Credit Allowance Applies

In case of an interruption to any service, allowance for the period of interruption, if not due to the negligence of the customer or End User, shall be as follows:

- (1) For services, other than those mentioned in (2) and (6) following, no credit shall be allowed for an interruption of less than 30 minutes. The customer shall be credited for an interruption of 30 minutes or more at the rate of 1/1440 of the monthly charge for the service for the initial period of 30 minutes. Additionally, credit will be provided in 15 minute increments during the period that the interruption continues at the rate of 1/2880 of the monthly charge. The monthly charges used to determine the credit shall be as follows:
- (a) For two-point services, the monthly charge shall be the total of all the monthly rate element charges associated with the service.

Advice No. 03-28

Issued July 23, 2003

Effective August 23, 2003

Issued By CENTURYTEL OF WASHINGTON, INC. d/b/a CenturyTel
P.O. Box 9901, Vancouver, WA

(C)

By Pamela Donovan Title Supervisor, Tariffs

ACCESS SERVICE

2. General Regulations (Cont'd)

2.4 Payment Arrangements and Credit Allowances (Cont'd)

2.4.4 Credit Allowance for Service Interruptions (Cont'd)

(B) When A Credit Allowance Applies (Cont'd)

(1) (Cont'd)

- (b) For multipoint services, the monthly charge shall be only the total of all the monthly rate element charges associated with that portion of the service that is inoperative (i.e., a channel termination per customer premises, channel mileage and optional features and functions).
- (c) For multiplexed services, the monthly charge shall be the total of all the monthly rate element charges associated with that portion of the service that is inoperative. When the facility which is multiplexed or the multiplexer itself is inoperative, the monthly charge shall be the total of all the monthly rate element charges associated with the service (i.e., the channel termination, channel mileage and optional features and functions, including the multiplexer on the facility to the hub, and the channel terminations, channel mileages and optional features and functions on the individual services from the hub). When the service which rides a channel of the multiplexed facility is inoperative, the monthly charge shall be the total of all the monthly rate element charges associated with that portion of the service from the hub to a customer premises (i.e., channel termination, channel mileage and optional features and functions).

Advice No. 03-28

Issued July 23, 2003

Effective August 23, 2003

Issued By CENTURYTEL OF WASHINGTON, INC. d/b/a CenturyTel
P.O. Box 9901, Vancouver, WA

(C)

By Pamela Donovan Title Supervisor, Tariffs

ACCESS SERVICE

2. General Regulations (Cont'd)

2.4 Payment Arrangements and Credit Allowances (Cont'd)

2.4.4 Credit Allowance for Service Interruptions (Cont'd)

(B) When A Credit Allowance Applies (Cont'd)

- (2) For Switched Access Service and Directory Assistance Service, no credit shall be allowed for an interruption of less than 24 hours. The customer shall be credited for an interruption of 24 hours or more at the rate of 1/30 of the applicable monthly rates or minimum monthly usage charge for each period of 24 hours or major fraction thereof that the interruption continues.
- (3) The credit allowance(s) for an interruption or for a series of interruptions shall not exceed the monthly rate and minimum monthly usage charge for the service interrupted in any one monthly billing period.
- (4) For certain Special Access services (Wideband Digital, WA1-3; Digital Data Access, DA1-4; and High Capacity, HC1), any period during which the error performance is below that specified for the service will be considered as an interruption.
- (5) Service interruptions for Specialized Service or Arrangements provided under the provisions of 12. following shall be administered in the same manner as those set forth in this section (2.4.4) unless other regulations are specified with the individual case filing.

Advice No. 03-28

Issued July 23, 2003

Effective August 23, 2003

Issued By CENTURYTEL OF WASHINGTON, INC. d/b/a CenturyTel
P.O. Box 9901, Vancouver, WA

(C)

By Pamela Donovan Title Supervisor, Tariffs

ACCESS SERVICE

2. General Regulations (Cont'd)

2.4 Payment Arrangements and Credit Allowances (Cont'd)

2.4.4 Credit Allowance for Service Interruptions (Cont'd)

(C) When Credit Allowance Does Not Apply (Cont'd)

No credit allowance will be made for:

- (1) Interruptions caused by the negligence of the customer.
- (2) Interruptions of a service due to the failure of equipment or systems provided by the customer or others.
- (3) Interruptions of a service during any period in which the Telephone Company is not afforded access to the premises where the service is terminated.
- (4) Interruptions of a service during the first 30 minute period when the customer has released a service to the Telephone Company for maintenance purposes, to make rearrangements, or for the implementation of an order for a change in the service. Thereafter, a credit allowance as set forth in (B)(1) preceding applies.
- (5) Interruptions of a service which continue because of the failure of the customer to authorize replacement of any element of special construction, as set forth in Section 12 following. The period for which no credit allowance is made begins on the seventh day after the customer receives the Telephone Company's written notification of the need for such replacement and ends on the day after receipt by the Telephone Company of the customer's written authorization for such replacement.
- (6) Periods when the customer elects not to release the service for testing and/or repair and continues to use it on an impaired basis.
- (7)
- (8) An interruption or a group of interruptions, resulting from a common cause, for amounts less than one dollar.

Advice No. 03-28

Issued July 23, 2003

Effective August 23, 2003

Issued By CENTURYTEL OF WASHINGTON, INC. d/b/a CenturyTel
P.O. Box 9901, Vancouver, WA

(C)

By Pamela Donovan Title Supervisor, Tariffs

WN U-4

Second Revised Sheet No. 42
Cancels
First Revised Sheet No. 42
CENTURYTEL OF WASHINGTON, INC.

(C)

ACCESS SERVICE

2. General Regulations (Cont'd)

RESERVED FOR FUTURE USE

Advice No. 03-28

Issued July 23, 2003 Effective August 23, 2003
Issued By CENTURYTEL OF WASHINGTON, INC. d/b/a CenturyTel
 P.O. Box 9901, Vancouver, WA
By Pamela Donovan Title Supervisor, Tariffs

(C)

WN U-4

Third Revised Sheet No. 43
Cancels
Second Revised Sheet No. 43
CENTURYTEL OF WASHINGTON, INC.

(C)

ACCESS SERVICE

2. General Regulations (Cont'd)

RESERVED FOR FUTURE USE

Advice No. 03-28

Issued July 23, 2003 Effective August 23, 2003
Issued By CENTURYTEL OF WASHINGTON, INC. d/b/a CenturyTel (C)
 P.O. Box 9901, Vancouver, WA
By Pamela Donovan Title Supervisor, Tariffs

ACCESS SERVICE

2. General Regulations (Cont'd)

2.6 Definitions

Certain terms used herein are defined as follows:

Access Code

The term "Access Code" denotes a uniform four or seven digit code assigned by the Telephone Company to an individual customer. The four digit code has the form 10XX, and the seven digit code has the form 950-10XX.

Access Minutes

The term "Access Minutes" denotes that usage of exchange facilities in intrastate service for the purpose of calculating chargeable usage. On the originating end of an intrastate call, usage is measured from the time the originating End User's call is delivered by the Telephone Company to and acknowledged as received by the customer's facilities connected with the originating exchange. On the terminating end of an intrastate call, usage is measured from the time the call is received by the End User in the terminating exchange. Timing of usage at both originating and terminating ends of an intrastate call shall terminate when the calling or called party disconnects, whichever event is recognized first in the originating and terminating end exchanges, as applicable.

Access Tandem

The term "Access Tandem" denotes a Telephone Company switching system that provides a concentration and distribution function for originating or terminating traffic between end offices and customers' premises.

Answer/Disconnect Supervision

The term "Answer/Disconnect Supervision" denotes the transmission of the switch trunk equipment supervisory signal (off-hook or on-hook) to the customers point of termination as an indication that the called party has answered or disconnected.

Advice No. 03-28

Issued July 23, 2003

Effective August 23, 2003

Issued By CENTURYTEL OF WASHINGTON, INC. d/b/a CenturyTel
P.O. Box 9901, Vancouver, WA

(C)

By Pamela Donovan Title Supervisor, Tariffs

ACCESS SERVICE

2. General Regulations (Cont'd)
2.6 Definitions (Cont'd)

Attenuation Distortion

The term "Attenuation Distortion" denotes the difference in loss at specified frequencies relative to the loss at 1004 Hz, unless otherwise specified.

Balance (100 Type) Test Lines

The term "Balance (100 Type) Test "Line" denotes an arrangement in an end office which provides for balance and noise testing.

Bit

The term "Bit" denotes the smallest unit of information in the binary system of notation.

Business Day

The term "Business Day" denotes the times of day that a company is open for business. Generally, in the business community there are 8:00 or 9:00 a.m. to 5:00 or 6:00 p.m., respectively, with an hour for lunch, Monday through Friday, resulting in a standard forty (40) hour work week.

Advice No. 03-28

Issued July 23, 2003

Effective August 23, 2003

Issued By CENTURYTEL OF WASHINGTON, INC. d/b/a CenturyTel
P.O. Box 9901, Vancouver, WA

(C)

By Pamela Donovan Title Supervisor, Tariffs

ACCESS SERVICE

2. General Regulations (Cont'd)
2.6 Definitions (Cont'd)

Coin Station

The term "Coin Station" denotes a location where Telephone Company equipment is provided in a public or semipublic place where Telephone Company customers can originate telephonic communications and pay the applicable charges by inserting coins into the equipment.

Common Carrier

See Carriers

Common Line

The term "Common Line" denotes a line, trunk, pay telephone line or other facility provided under the general and/or local exchange service tariffs of the Telephone Company, terminated on a central office switch. and .a common line-residence is a line or trunk provided under the residence regulations of the general and/or local exchange service tariffs. A common line-business is a line provided under the business regulations of the general and/or local exchange service tariffs.

Communications System

The term "Communications System" denotes channels and other facilities which are capable of communications between terminal equipment provided by other than the Telephone Company.

Customer(s)

The term "Customer(s)" denotes any individual, partnership, association, joint-stock company, trust, corporation, or governmental entity or any other entity which subscribes to the services offered under this tariff, including both Interexchange or Intraexchange Carriers (IC's) and End Users.

Advice No. 03-28

Issued July 23, 2003

Effective August 23, 2003

Issued By CENTURYTEL OF WASHINGTON, INC. d/b/a CenturyTel
P.O. Box 9901, Vancouver, WA

(C)

By Pamela Donovan Title Supervisor, Tariffs

ACCESS SERVICE

2. General Regulations (Cont'd)
2.6 Definitions (Cont'd)

Data Transmission (107 Type) Test Line

The term "Data Transmission (107 Type) Test Line" denotes an arrangement which provides for a connection to a signal source which provides test signals for one-way testing of data and voice transmission parameters.

Decibel

The term "Decibel" denotes a unit used to express relative difference in power, usually between acoustic or electric signals, equal to ten (10) times the common logarithm of the ratio of two signal powers.

Decibel Reference Noise C-Message Weighting

The term "Decibel Reference Noise C-Message weighting" denotes noise power measurements with C-Message weighting in decibels relative to a reference 1000 Hz tone of 90 dB below 1 milliwatt.

Decibel Reference Noise C-Message Referenced to 0

The term "Decibel Reference Noise C-Message Referenced to 0" denotes noise power in the "Decibel Reference Noise C-Message Weighting" referred to or measured at zero transmission level point.

Detail Billing

The term "Detail Billing" denotes the listing of each message and/or rate element for which charges to a customer are due on a bill prepared by the Telephone Company.

Dialing Parity

Allows end user customers to choose from two or more Telecommunications Service Providers without requiring an access code (i.e., one provider for IntraLATA services and another provider for InterLATA services).

Direct-Trunked Transport

The term "Direct-Trunked Transport" denotes transport from the serving wire center to the end office or from the serving wire center to the access tandem on circuits dedicated to the use of a single customer.

Directory Assistance (Intrastate)

The term "Directory Assistance" denotes the provision of telephone numbers by a Telephone Company operator when the operator location is accessed by a customer by dialing 555-1212.

Advice No. 03-28

Issued July 23, 2003

Effective August 23, 2003

Issued By CENTURYTEL OF WASHINGTON, INC. d/b/a CenturyTel

P.O. Box 9901, Vancouver, WA

(C)

By Pamela Donovan

Title Supervisor, Tariffs

ACCESS SERVICE

2. General Regulations (Cont'd)
2.6 Definitions (Cont'd)

Effective 4-Wire

The term "Effective 4-Wire" denotes a condition which permits the simultaneous independent transmission of information in both directions over a channel. The method of implementing effective 4-wire transmission is at the discretion of the Telephone Company (physical, time domain, frequency-domain separation or echo cancellation techniques). Effective 4-wire channels may be terminated with a 2-wire interface at the customer's premises. However, when terminated 2-wire, simultaneous independent transmission cannot be supported because the two-wire interface combines the transmission paths into a single path.

End Office Switch

The term "End Office Switch" denotes a local Telephone Company switching system where Telephone Exchange Service customer station loops are terminated for purposes of interconnection to trunks. Included are Remote Switching Modules (RSM) and Remote Switching Systems (RSS) served by a host office in a different wire center.

End User

The term "End User" means any customer of an intrastate telecommunications service that is not a carrier, except that a carrier other than a telephone company shall be deemed to be an "end user" when such carrier uses a telecommunications service for administrative purposes, and a person or entity that offers telecommunications service exclusively as a reseller shall be deemed to be an "end user" if all resale transmissions offered by such reseller originate on the premises of such reseller.

Entrance Facility

The term "Entrance Facility" denotes a Switched Access Service dedicated Local Transport facility between the customer's serving wire center and the customer designated premises.

Entry Switch

See First Point of Switching

Advice No. 03-28

Issued July 23, 2003 Effective August 23, 2003
Issued By CENTURYTEL OF WASHINGTON, INC. d/b/a CenturyTel
 P.O. Box 9901, Vancouver, WA
By Pamela Donovan Title Supervisor, Tariffs

(C)

ACCESS SERVICE

2. General Regulations (Cont'd)
2.6 Definitions (Cont'd)

Envelope Delay Distortion

The term "Envelope Delay Distortion" denotes a measure of the linearity of the phase versus frequency of a channel.

Equal Level Echo Path Loss

The term "Equal Level Echo Path Loss" denotes the measure of Echo Path Loss (EPL) at a 4-wire interface which is corrected by the difference between the send and receive transmission Level Point (TLP). [ELEPL = EPL - TLP (send) + TLP (receive)].

Expected Measured Loss

The term "Expected Measured Loss" denotes a calculated loss which specifies the end-to-end 1004-Hz transducer loss on a terminated test connection between two readily accessible manual or remote test points. It is the sum of the inserted connection loss and test access loss including any test pads.

Exchange

The term "Exchange" denotes a unit generally smaller than a Local Access and Transport Area established by the Telephone Company for the administration of communications service in a specified area which usually embraces a city, town or village and its environs. It consists of one or more central offices together with the associated facilities used in furnishing communications service within that area. One or more designated exchanges comprise a given Local Access and Transport Area.

Field Identifier

The term "Field Identifier" denotes two to four characters that are used on service orders to convey specific instructions. Field Identifiers may or may not have associated data. Selected field identifiers are used in Telephone Company billing systems to generate nonrecurring charges.

Advice No. 03-28

Issued July 23, 2003

Effective August 23, 2003

Issued By CENTURYTEL OF WASHINGTON, INC. d/b/a CenturyTel
P.O. Box 9901, Vancouver, WA

(C)

By Pamela Donovan Title Supervisor, Tariffs

ACCESS SERVICE

2. General Regulations (Cont'd)
2.6 Definitions (Cont'd)

Grandfathered

The term "Grandfathered" denotes Terminal Equipment, Multiline Terminating Systems and Protective Circuitry directly connected to the facilities utilized to provide services under the provisions of this tariff, and which are considered grandfathered under Part 68 of the F.C.C.'s Rules and Regulations.

Host Office

The term "Host Office" denotes an electronic switching system which provides call processing capabilities for one or more Remote Switching Modules or Remote Switching Systems.

Immediately Available Funds

The term "Immediately Available Funds" denotes New York Certificates of Deposit, bank wire transfers, U.S. Federal Reserves Notes (paper cash) U.S. coins and U.S. Postal Money Orders and a corporate or personal check drawn on a bank account.

Impedance Balance

The term "Impedance Balance" denotes the method of expressing Echo Return Loss and Singing Return Loss at a 4-wire interface whereby the gains and/or loss of the 4 wire portion of the transmission path, including the hybrid, are not included in the specification.

Impulse Noise

The term "Impulse Noise" denotes any momentary occurrence of the noise on a channel over a specified level threshold. It is evaluated by counting the number of occurrences which exceed the threshold.

Advice No. 03-28

Issued July 23, 2003

Effective August 23, 2003

Issued By CENTURYTEL OF WASHINGTON, INC. d/b/a CenturyTel
P.O. Box 9901, Vancouver, WA

(C)

By Pamela Donovan Title Supervisor, Tariffs

ACCESS SERVICE

2. General Regulations (Cont'd)
2.6 Definitions (Cont'd)

Individual Case Basis

The term "Individual Case Basis" denotes a condition in which the regulations, if applicable, rates and charges for an offering under the provisions of this tariff are developed based on the circumstances in each case.

Inserted Connection Loss

The term "Inserted Connection Loss" denotes the 1004 Hz power difference (in dBs) between the maximum power available at the originating end and the actual power reaching the terminating end through the inserted connection.

Interexchange Carrier (IC) or Interexchange Common Carrier

The term "Interexchange Carrier" (IC) or "Interexchange Common Carrier" denotes any individual, partnership, association, joint stock company, trust, governmental entity or corporation engaged for hire in intrastate communications by wire or radio, between two or more exchanges.

Intermodulation Distortion

The term "Intermodulation Distortion" denotes a measure of the nonlinearity of a channel. It is measured using four tones, and evaluating the ratios (in dB) of the transmitted composite four-tone signal power to the second-order products of the tones (R2), and the third-order products of the tones (R3).

Interstate Communications

The term "Interstate Communications" denotes both interstate and foreign communications.

Advice No. 03-28

Issued July 23, 2003

Effective August 23, 2003

Issued By CENTURYTEL OF WASHINGTON, INC. d/b/a CenturyTel
P.O. Box 9901, Vancouver, WA

(C)

By Pamela Donovan Title Supervisor, Tariffs

ACCESS SERVICE

2. General Regulations (Cont'd)
2.6 Definitions (Cont'd)

Loss Deviation

The term "Loss Deviation" denotes the variation of the actual loss from the designed value.

Message

The term "Message" denotes a "call" as defined preceding.

Milliwatt (102 Type) Test Line

The term "Milliwatt" (102 Type) Test Line" denotes an arrangement in an end office which provides a 1004 Hz tone at 0 dBm0 for one-way transmission measurements towards the customer's premises from the Telephone Company end office.

Network Control Signaling

The term "Network Control Signaling" denotes the transmission of signals used in the telecommunications system which perform functions such as supervision (control, status, and charge signals), address signaling (e.g., dialing), calling and called number identifications rate of flow, service selection error control and audible tone signals (call progress signals indicating re-order or busy conditions, alerting, coin denominations, coin collect and coin return tones) to control the operation of the telecommunications system.

Nonsynchronous Test Line

The term "Nonsynchronous Test Line" denotes an arrangement in step-by-step end offices which provides operational tests which are not as complete as those provided by the synchronous test lines, but can be made more rapidly.

Advice No. 03-28

Issued July 23, 2003

Effective August 23, 2003

Issued By CENTURYTEL OF WASHINGTON, INC. d/b/a CenturyTel
P.O. Box 9901, Vancouver, WA

(C)

By Pamela Donovan Title Supervisor, Tariffs

ACCESS SERVICE

2. General Regulations (Cont'd)
2.6 Definitions (Cont'd)

North American Numbering Plan

The term "North American Numbering Plan" denotes a three-digit area (Numbering Plan Area) code and a seven-digit telephone number made up of a three-digit Central Office code plus a four-digit station number.

Off-hook

The term "Off-hook" denotes the active condition of Switched Access or a Telephone Exchange Service line.

On-hook

The term "On-hook" denotes the idle condition of Switched Access or a Telephone Exchange Service line.

Open Circuit Test Line

The term "Open Circuit Test Line" denotes an arrangement in an end office which provides an ac open circuit termination of a trunk or line by means of an inductor of several Henries.

Originating Direction

The term "Originating Direction" denotes the use of access service for the origination of calls from an End User Premises to an IC premises location.

Pay Telephone

The term "Pay Telephone" denotes Telephone Company provided instruments and related facilities that are available to the general public for public convenience and necessity, including public and semipublic telephones, coinless telephones and limited pay telephones.

Advice No. 03-28

Issued July 23, 2003

Effective August 23, 2003

Issued By CENTURYTEL OF WASHINGTON, INC. d/b/a CenturyTel
P.O. Box 9901, Vancouver, WA

(C)

By Pamela Donovan

Title Supervisor, Tariffs

ACCESS SERVICE

2. General Regulations (Cont'd)
2.6 Definitions (Cont'd)

Registered Equipment

The term "Registered Equipment" denotes the customer's premises equipment which complies with and has been approved within the Registration Provisions of Part 68 of the F.C.C.'s Rules and Regulations.

Service Switching Point (SSP)

An end office or tandem switch equipped with the signaling link hardware and software that has the ability to halt call process, formulate and send an 800 query to a remote location and route the call based on the information contained in the response.

Seven Digit Manual Test Line

The term "Seven Digit Manual Test Line" denotes an arrangement which allows the customer to select balance, milliwatt and synchronous test lines by manually dialing a seven digit number over the associated access connection.

Short Circuit Test Line

The term "Short Circuit Test Line" denotes an arrangement in an end office which provides for an ac short circuit termination of a trunk or line by means of a capacitor of at least four microfarads.

Signal-to-C-Notched Noise Ratio

The term "Signal-to-C-Notched Noise Ratio" denotes the ratio in dB of a test signal to the corresponding C-Notched Noise.

Singing Return Loss

The term "Singing Return Loss" denotes the frequency weighted measure of return loss at the edges of the voiceband (200 to 500 Hz and 2500 to 3200 Hz), where singing (instability) problems are most likely to occur.

Special Order

The term "Special Order" denotes an order for a Billing and Collection Service or an order for a Directory Assistance Service.

Advice No. 03-28

Issued July 23, 2003

Effective August 23, 2003

Issued By CENTURYTEL OF WASHINGTON, INC. d/b/a CenturyTel

P.O. Box 9901, Vancouver, WA

(C)

By Pamela Donovan

Title Supervisor, Tariffs

ACCESS SERVICE

2. General Regulations (Cont'd)
2.6 Definitions (Cont'd)

Trunk

The term "Trunk" denotes a communications path connecting two switching systems in a network, used in the establishment of an end-to-end connection.

Trunk Group

The term "Trunk Group" denotes a set of trunks which are traffic engineered as a unit for the establishment of connections between switching systems in which all of the communications paths are interchangeable.

Trunk-Side Connection

The term "Trunk Side Connection" denotes the connection of a transmission path to the trunk side of a local exchange switching system.

Two-Wire to Four-Wire Conversion

The term "Two-Wire to Four-Wire Conversion" denotes an arrangement which converts a four-wire transmission path to a two-wire transmission path to allow a four-wire facility to terminate in a two-wire entity (e.g., a central office switch).

Uniform Service Order Code

The term "Uniform Service Order Code" denotes a three or five character alphabetic, numeric, or an alphanumeric code that identifies a specific item of service or equipment. Uniform Service Order Codes are used in the Telephone Company billing system to generate recurring rates and nonrecurring charges.

Advice No. 03-28

Issued July 23, 2003

Effective August 23, 2003

Issued By CENTURYTEL OF WASHINGTON, INC. d/b/a CenturyTel
P.O. Box 9901, Vancouver, WA

(C)

By Pamela Donovan Title Supervisor, Tariffs

WN U-4

First Revised Sheet No. 67
Cancels
Original Sheet No. 67
CENTURYTEL OF WASHINGTON, INC.

(C)

ACCESS SERVICE

4.

(This Sheet Reserved for Future Use)

Advice No. 03-28

Issued July 23, 2003 Effective August 23, 2003
Issued By CENTURYTEL OF WASHINGTON, INC. d/b/a CenturyTel
 P.O. Box 9901, Vancouver, WA
By Pamela Donovan Title Supervisor, Tariffs

(C)

ACCESS SERVICE

5. Ordering Options for Switched and Special Access Service

5.1 General (Cont'd)

5.1.2 Provision of Other Services

- (A) Testing Service, Additional Labor, Restoration Priority and Special Facilities Routing shall be ordered with an Access Order or as subsequently set forth in (B) following. The rates and charges for these services, as set forth in other sections of this tariff, will apply in addition to the ordering charges set forth in this section and the rates and charges for the Access Service with which they are associated.
- (B) With the agreement of the Telephone Company, the items listed in (A) preceding may subsequently be added to the order at any time, up to and including the service date for the Access Service. When added subsequently, charges for order modifications as set forth in 5.2.2 following will apply when an engineering review is required.
- (C) The Telephone Company is bound by a written estimate of charges given to a customer, however, should the requirements for facilities or services change by a customer request for unique services which differ from services presently provided, additional engineering will apply. Additional Engineering is not an ordering option, but will be applied to an Access Order when the Telephone Company determines Additional Engineering is necessary to accommodate a customer request. When Additional Engineering is required, the customer will be so notified and will be furnished with a written statement setting forth the justification for the Additional Engineering as well as an estimate of the charges. If the customer agrees to the Additional Engineering, a firm order will be established. If the customer does not want the service or facilities after being notified that Additional Engineering is required, the order will be withdrawn and no charges will apply. Once a firm order has been established, the total charge to the customer for the additional engineering may not exceed the estimated amount by more than 10%.

The regulations, rates and charges for Additional Engineering are as set forth in Sections 13, 16, 17 and 18 following and are in addition to the regulations, rates and charges specified in this section.

Advice No. 03-28

Issued July 23, 2003

Effective August 23, 2003

Issued By CENTURYTEL OF WASHINGTON, INC. d/b/a CenturyTel
P.O. Box 9901, Vancouver, WA

(C)

By Pamela Donovan Title Supervisor, Tariffs

ACCESS SERVICE

5. Ordering Options for Switched and Special Access Service

5.1 General (Cont'd)

5.1.3 Special Construction

The regulations, rates and charges for special construction will be developed on an individual case basis and are in addition to the regulations, rates and charges specified in this section.

5.2 Access Order

An Access Order is used by the Telephone Company to provide to a customer Access Service as follows:

Switched Access Services as set forth in 6. following,

Special Access Services as described in 7. following, and

Other Services as set forth in 5.1.2 preceding.

For 800 Access Service, the customer shall order the service in accordance with the preceding provisions for ordering Feature Group D, except that customers may request direct connections to only those end offices and access tandems equipped with 800 Service Switching Point (800 SSP) functionality. All 800 traffic originating from end offices not equipped with the 800 SSP function must be routed via an access tandem at which the function is available and the 800 Access Service must be ordered accordingly. 800 SSP locations are identified in the National Exchange Carrier Association Tariff F.C.C. No. 4.

Advice No. 03-28

Issued July 23, 2003

Effective August 23, 2003

Issued By CENTURYTEL OF WASHINGTON, INC. d/b/a CenturyTel
P.O. Box 9901, Vancouver, WA

(C)

By Pamela Donovan Title Supervisor, Tariffs

ACCESS SERVICE

5. Ordering Options for Switched and Special Access Service (Cont'd)
5.2 Access Order (Cont'd)

When ordering Switched Access service, the customer must specify whether the service is to be provided as (1) Direct Trunked Transport to the end office, (2) Direct Trunked Transport to a tandem which connects with Tandem Switched Transport from the tandem to the end office or (3) Tandem Switched Transport to the end office. When all or a portion of service is ordered as Direct Trunked Transport, the customer must specify the type and quantity of Direct Trunked Transport facility (e.g., Voice Grade or High Capacity DS1 or DS3).

The Customer must also specify the type of Entrance Facility to be used for Switched Access (e.g., Voice Grade or High Capacity). For High Capacity Entrance Facilities, the customer must specify the facility assignment and the channel assignment for each trunk.

Direct Trunked Transport is available at all tandems and at all end offices except those end offices identified in NATIONAL EXCHANGE CARRIER ASSOCIATION, INC. TARIFF F.C.C. NO. 4. as not having the capability to provide Direct Trunked Transport. Direct Trunked Transport is not available: (1) from end offices that provide equal access through a Centralized Equal Access arrangement, or (2) from end offices that lack recording or measurement capability.

Normally, Direct Trunked Transport of originating 800 series calls from an end office is available only from Service Switching Point (SSP) equipped end offices. However, certain SSP equipped end offices cannot accommodate the direct trunking of the 888 service access code. These end offices are identified in NATIONAL EXCHANGE CARRIER ASSOCIATION, INC., TARIFF F.C.C. NO. 4. Additionally, certain non-SSP equipped end offices can accommodate direct trunking of originating 800 series calls. These end offices are also identified in NATIONAL EXCHANGE CARRIER ASSOCIATION, INC., TARIFF F.C.C. No. 4.

When the customer has both Tandem Switched Transport and Direct Trunked Transport at the same end office, the customer will be provided Alternate Traffic Routing as set forth in 6.4.6 following.

Advice No. 03-28

Issued July 23, 2003

Effective August 23, 2003

Issued By CENTURYTEL OF WASHINGTON, INC. d/b/a CenturyTel
P.O. Box 9901, Vancouver, WA

(C)

By Pamela Donovan Title Supervisor, Tariffs

ACCESS SERVICE

5. Ordering Options for Switched and Special Access Service (Cont'd)
5.2 Access Order (Cont'd)

The BHMC is determined in the following manner. For each business day, the customer shall determine the highest number of minutes of use for a single hour (e.g., 55 minutes in the 10-11 AM hour). The customer shall, for the same hour period (i.e., busy hour) for each of twenty consecutive days, pick the twenty consecutive days in a calendar year which add up to the largest number of minutes of use. Both originating and terminating minutes shall be included. The customer shall then determine the average busy hour minutes of capacity (i.e., BHMC) by dividing largest number of minutes of use figure for the same hour period for the consecutive twenty day period by 20. This computation shall be performed for each end office the customer wishes to serve. These determinations thus establish the BHMC for each end office.

Where the Special Access Service is exempt from the Special Access Surcharge, as set forth in Section 7.4.2, the customer shall furnish with the order the certification as set forth in Section 7.4.2.

5.2.1 Access Order Service
Access Service is provided as follows:

To the extent the Access Service can be made available with reasonable effort, the Telephone Company will provide the Access Service in accordance with the customer's request on a first-come, first-served basis, subject to the following conditions:

Access Services provided will be installed during the business day. If a customer requests that installation be done outside of scheduled work hours, and the Telephone Company agrees to this request, the customer will be subject to applicable Additional Labor Charges as set forth in Sections 16, 17 and 18 following.

Advice No. 03-28

Issued July 23, 2003

Effective August 23, 2003

Issued By CENTURYTEL OF WASHINGTON, INC. d/b/a CenturyTel
P.O. Box 9901, Vancouver, WA

(C)

By Pamela Donovan Title Supervisor, Tariffs

ACCESS SERVICE

5. Ordering Options for Switched and Special Access Service (Cont'd)

5.2 Access Order (Cont'd)

5.2.2 Access Order Modifications (Cont'd)

(B) Partial Cancellation Charge

Any decrease in the number of ordered Special Access Services channels or Switched Access Service lines, trunks or busy hour minutes of capacity will be treated as a partial cancellation and the charges as set forth in 5.2.3(C) following will apply.

(C) Design Change Charge

The customer may request a design change to the service ordered. A design change is any change to an Access Order which requires engineering review. An engineering review is a review by Telephone Company personnel, of the service ordered and the requested changes to determine what changes in the design, if any, are necessary to meet the changes requested by the customer. Design changes include such things as the addition or deletion of optional features of functions or a change in the type of Transport Termination (Switched Access only), type of channel interface, type of Interface Group or technical specification package. Design changes do not include a change of customer premises, and user premises, end office switch, Feature Group type or Special Access Service channel type. Changes of this nature will require the issuance of a new order and the cancellation of the original order with appropriate cancellation charges applied.

Advice No. 03-28

Issued July 23, 2003

Effective August 23, 2003

Issued By CENTURYTEL OF WASHINGTON, INC. d/b/a CenturyTel
P.O. Box 9901, Vancouver, WA

(C)

By Pamela Donovan Title Supervisor, Tariffs

ACCESS SERVICE

5. Ordering Options for Switched and Special Access Service (Cont'd)

5.2 Access Order (Cont'd)

5.2.2 Access Order Modification (Cont'd)

(C) Design Change Charges (Cont'd)

The Telephone Company will review the requested change, notify the customer whether the change is a design change, if it can be accommodated and if a new service date is required. If the customer authorizes the Telephone Company to proceed with the design change, a Design Change Charge will apply. The Design Change Charge will apply on a per order per occurrence basis, for each order requiring a design change. The applicable charge is listed in Sections 16, 17 and 18 following.

If a change of service date is required, the Service Date Change Charge as set forth in Sections 16, 17 and 18 following will also apply.

(D) Expedited Order Charge

When placing an Access Order, a customer may request a service date. A customer may also request an earlier service date on a pending Access Order. If the Telephone Company determines it can provide service on the requested date and it determines additional labor cost or extraordinary costs are required, it will notify the customer and provide an estimate of the additional charges involved. Such additional charges will be determined and billed to the customer as follows:

Advice No. 03-28

Issued July 23, 2003

Effective August 23, 2003

Issued By CENTURYTEL OF WASHINGTON, INC. d/b/a CenturyTel
P.O. Box 9901, Vancouver, WA

(C)

By Pamela Donovan Title Supervisor, Tariffs

ACCESS SERVICE

5. Ordering Options for Switched and Special Access Service (Cont'd)

5.2 Access Order (Cont'd)

5.2.2 Access Order Modifications (Cont'd)

(D) Expedited Order Charge (Cont'd)

To calculate the additional labor charges, the Telephone Company, upon authorization from the customer for the Telephone Company to incur the additional labor charges and to bill the customer for such charges, will keep track of the additional labor hours used to meet the request of the customer and will bill the customer at the applicable Additional Labor charges as set forth in Sections 16, 17 and 18 following.

To develop, determine and bill the customer the extraordinary costs which may be involved, the special construction terms and conditions as set forth in Section 12 will be used by the Telephone Company. Authorization to incur the costs and to bill the customer will be in accordance with Section 12 following.

When the request for expediting occurs subsequent to the issuance of the Access Order, a Service Date Change Charge as set forth in Sections 16, 17 and 18 following also applies.

Advice No. 03-28

Issued July 23, 2003

Effective August 23, 2003

Issued By CENTURYTEL OF WASHINGTON, INC. d/b/a CenturyTel
P.O. Box 9901, Vancouver, WA

(C)

By Pamela Donovan Title Supervisor, Tariffs

ACCESS SERVICE

5. Ordering Options for Switched and Special Access Service (Cont'd)

5.2 Access Order (Cont'd)

5.2.3 Cancellation of an Access Order

- (A) A customer may cancel an Access Order for the installation of service on any date prior to the service date. The cancellation date is the date the Telephone Company receives written or verbal notice from the customer that the order is to be canceled. The verbal notice must be followed by written confirmation within 10 days. If a customer or a customer's end user is unable to accept Access Service within 30 calendar days after the original service date, the customer has the choice of the following options:

The Access Order shall be canceled and charges set forth in Sections 16, 17 and 18 following will apply, or

Billing for the service will commence.

In such instances, the cancellation date or the billing date, depending on which option is selected by the customer, shall be the 31st day beyond the original service date of the Access Order.

Advice No. 03-28

Issued July 23, 2003

Effective August 23, 2003

Issued By CENTURYTEL OF WASHINGTON, INC. d/b/a CenturyTel
P.O. Box 9901, Vancouver, WA

(C)

By Pamela Donovan Title Supervisor, Tariffs

ACCESS SERVICE

5. Ordering Options for Switched and Special Access Service (Cont'd)

5.2 Access Order (Cont'd)

5.2.3 Cancellation of an Access Order

- (C) When a customer cancels an Access Order for the installation or service, a Cancellation Charge will apply as follows:
- (1) Installation of Switched or Special Access Service facilities is considered to have started when the Telephone Company incurs any cost in connection therewith or in preparation thereof which would not otherwise have been incurred.
 - (2) Where the customer cancels an Access Order prior to the start of installation of access facilities, no charges shall apply.
 - (3) Where installation of access facilities has been started prior to the cancellation, the charges specified in (a) or (b) following, whichever is lower, shall apply.
 - (a) A charge equal to the costs incurred in such installation, less estimated net salvage. Such charge is determined as detailed in (4) following.
 - (b) The charge for the minimum period of Switched or Special Access Service ordered by the customer.
 - (4) Charges applicable as specified in (3)(a) preceding include the nonrecoverable cost of equipment and material ordered, provided or used, plus the nonrecoverable cost of installation and removal including the costs of engineering, labor, supervision, transportation, rights-of-way and other associated costs.

Advice No. 03-28

Issued July 23, 2003

Effective August 23, 2003

Issued By CENTURYTEL OF WASHINGTON, INC. d/b/a CenturyTel
P.O. Box 9901, Vancouver, WA

(C)

By Pamela Donovan Title Supervisor, Tariffs

ACCESS SERVICE

5. Ordering Options for Switched and Special Access Service (Cont'd)

5.2 Access Order (Cont'd)

5.2.3 Cancellation of an Access Order (Cont'd)

- (D) When a customer cancels an order for the discontinuance of service, no charges apply for the cancellation.
- (E) If the Telephone Company misses a service date by more than 30 days due to circumstances over which it has direct control (excluding, e.g., acts of God, governmental requirements, work stoppages and civil commotions), the customer may cancel the Access Order without incurring cancellation charges.

5.2.4 Selection of Planned Facilities for Access Orders

- (A) When there are analog or digital high capacity facilities to a Hub on order or in service for the customer's use, the customer may request a specific channel or transmission path be used to provide the Switched or Special Access Service requested in an Access Order. The Telephone Company will make a reasonable effort to accommodate the customer request.
- (B) For all other Access Orders, the option to request a specific transmission path or channel is not provided except as provided for under Special Facilities Routing as set forth in 11. following.

5.2.5 Minimum Period

The minimum period for which Access Service is provided and for which charges are applicable, is one month.

Advice No. 03-28

Issued July 23, 2003

Effective August 23, 2003

Issued By CENTURYTEL OF WASHINGTON, INC. d/b/a CenturyTel
P.O. Box 9901, Vancouver, WA

By Pamela Donovan

Title Supervisor, Tariffs

(C)

ACCESS SERVICE

5. Ordering Options for Switched and Special Access Service (Cont'd)

5.2 Access Order (Cont'd)

5.2.6 Minimum Period Charges

When Access Service is disconnected prior to the expiration of the minimum period, charges are applicable for the balance of the minimum period. A disconnect constitutes facilities being returned to available inventory.

The Minimum Period Charge for monthly billed services will be determined as follows:

- (A) For Switched Access Service the charge for a month or fraction thereof is equal to the applicable monthly charge for the capacity as set forth in Sections 16, 17 and 18 following.
- (B) For Special Access Service, the charge for a month or fraction thereof is the applicable monthly rates for the service as set forth in Sections 16, 17 and 18 following.

5.2.7 Shared Use Facilities

Shared Use (i.e., Switched and Special Access Services provided over the same analog or digital high capacity facilities) is allowed. Shared use facilities to a Hub will be ordered and provided as Special Access Service. Individual services utilizing these facilities must be ordered either as Switched Access Service or Special Access Service depending on the intended use, however, the facilities may be used to provide both service types. When placing the order for the Switched Access Service or the Special Access Service, the customer must specify a channel assignment for each service ordered.

Advice No. 03-28

Issued July 23, 2003

Effective August 23, 2003

Issued By CENTURYTEL OF WASHINGTON, INC. d/b/a CenturyTel
P.O. Box 9901, Vancouver, WA

(C)

By Pamela Donovan Title Supervisor, Tariffs

ACCESS SERVICE

6. Switched Access Service

6.1 General

Switched Access Service, which is available to customers for their use in furnishing their services

to end users, provides a two-point communications path between a customer designated premises and an end user's premises. It provides for the use of common terminating, switching, and trunking facilities and for the use of common subscriber plant of the Telephone Company. Switched Access Service provides for the ability to originate calls from an end user's premises to a customer designated premises, and to terminate calls from a customer designated premises to an end user's premises in the LATA where it is provided. Specific references to material describing the elements of Switched Access Service are provided in 6.1.3 and 6.5 through 6.9 following.

Rates and charges for Switched Access Service depend generally on the specific Feature Group ordered by the customer, e.g., for MTS or WATS services or MTS/WATS equivalent services, and whether it is provided in a Telephone Company end office that is equipped to provide equal or non-equal access. Rates and charges for Switched Access Service are set forth in Sections 16, 17 and 18 following. The application of rates for Switched Access Service is described in 6.4 following. Rates and charges for services other than Switched Access Service, e.g., a customer's interLATA toll message service, may also be applicable when Switched Access Service is used in conjunction with these other services. Descriptions of such applicability are provided in 6.4.5, 6.4.9, 6.5.1(H), 6.5.3, 6.6.1(G), 6.6.2(D) and 6.7.1(F) following. Finally, a credit is applied against line side Switched Access Service charges as described in 6.4.8 following.

6.1.1 Feature Group Arrangements and Manner of Provision

Switched Access Service is provided in four different Feature Group arrangements which are service categories of standard and optional features. These are differentiated by their technical characteristics, e.g., line side vs. trunk side connection at the Telephone Company first point of switching. They are also differentiated by optional feature availability and the manner in which the end user accesses them in originating calling, e.g., with or without access codes of various lengths and digits.

The provision of each Feature Group requires Local Transport facilities, including an Entrance Facility where required, and the appropriate End Office functions. In addition, Special Access Service may, at the option of the customer, be connected with Feature Groups A, B, C, or D at Telephone Company designated WATS Serving Offices.

Advice No. 03-28

Issued July 23, 2003

Effective August 23, 2003

Issued By CENTURYTEL OF WASHINGTON, INC. d/b/a CenturyTel
 P.O. Box 9901, Vancouver, WA

(C)

By Pamela Donovan Title Supervisor, Tariffs

ACCESS SERVICE

6. Switched Access Service (Cont'd)

6.1 General (Cont'd)

6.1.2 Dedicated Access Line Service

Dedicated Access Line Service is a type of Special Access Service that is provided only for use with Feature Group C and D Switched Access Service. Dedicated Access Line Service connects an end user premises with a WATS serving office. This service is described in 7.2.1(B) following.

6.1.3 Rate Categories

There are three rate categories which apply to Switched Access Service:

Local Transport (described in 6.1.3(A) following)

End Office (described in 6.1.3(C) following)

Common Line (described in Sections 3. and 4. preceding)

The following diagram depicts a generic view of the components of Switched Access Service and the manner in which the components are combined to provide a complete access service.

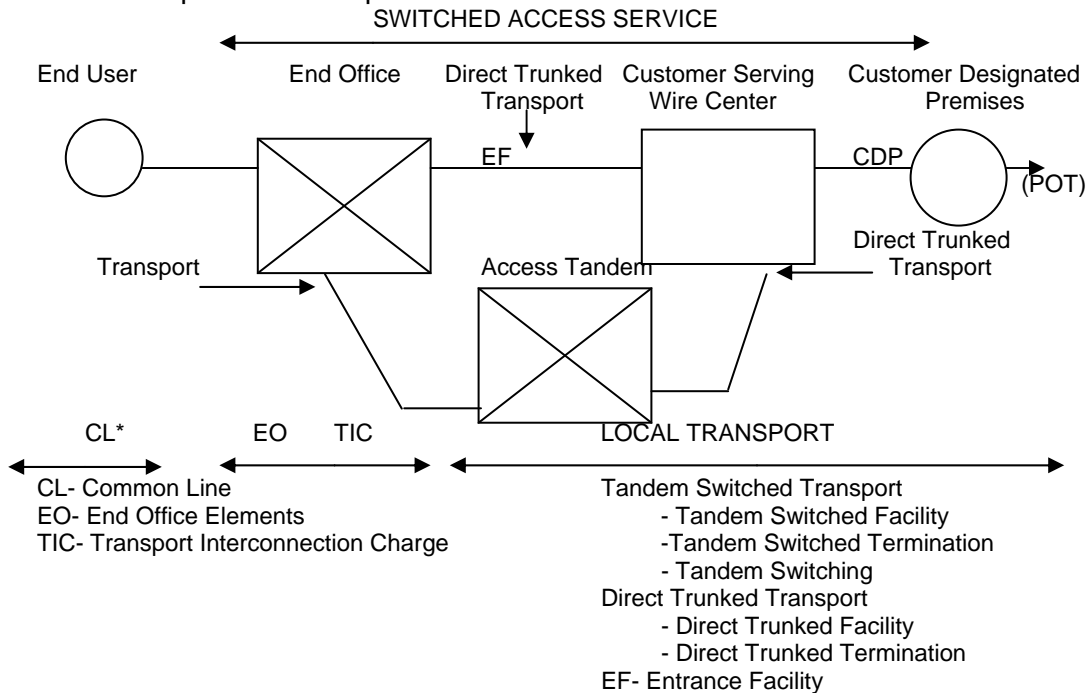

Common Line access is provided under WECA WN U-1.

Advice No. 03-28

Issued July 23, 2003

Effective August 23, 2003

Issued By CENTURYTEL OF WASHINGTON, INC. d/b/a CenturyTel
 P.O. Box 9901, Vancouver, WA

By Pamela Donovan Title Supervisor, Tariffs

ACCESS SERVICE

6. Switched Access Service (Cont'd)
 6.1 General (Cont'd)
 6.1.3 Rate Categories (Cont'd)
 (A) Local Transport (Cont'd)

Local Transport is provided at the rates and charges set forth in Sections 16, 17 and 18 following. The application of these rates with respect to individual Feature Groups is as set forth in 6.4.1(C) following. When more than one Telephone Company is involved in providing the Switched Access Service, the Local Transport rates are applied as set forth in 2.4.7 preceding.

The Local Transport Rate Category includes four classifications of rate elements: (1) Entrance Facility, (2) Direct Trunked Transport, (3) Tandem Switched Transport and (4) Multiplexing.

(1) Entrance Facility

The Entrance Facility recovers a portion of the costs associated with a communications path between a customer designated premises and the serving wire center of that premises. Included as part of the Entrance Facility is a standard channel interface arrangement which defines the technical characteristics associated with the type of facilities to which the access service is to be connected at the customer designated premises and the type of signaling capability, if any.

Three types of Entrance Facility are available: (1) Voice Grade 2 or 4 wire (an analog channel with an approximate bandwidth of 300 to 3000 Hz), (2) High Capacity DS1 (an isochronous serial digital channel with a rate of 1.544 Mbps) and (3) High Capacity DS3 (an isochronous serial digital channel with a rate of 44.736 Mbps). The minimum period for which a DS3 Entrance Facility is provided is twelve months.

One charge applies for each Entrance Facility that is terminated at a customer designated premises. This charge specified in Sections 16, 17 and 18 following will apply even if the customer designated premises and the serving wire center are collocated in a Telephone Company building.

A customer's Local Transport may be connected to the Entrance Facility of another customer, providing the other customer submits a Letter of Authorization for this connection and assumes full responsibility for the cost of the Entrance Facility.

Advice No. 03-28

Issued July 23, 2003

Effective August 23, 2003

Issued By CENTURYTEL OF WASHINGTON, INC. d/b/a CenturyTel
 P.O. Box 9901, Vancouver, WA
 By Pamela Donovan Title Supervisor, Tariffs

(C)

ACCESS SERVICE

6. Switched Access Service (Cont'd)
 6.1 General (Cont'd)
 6.1.3 Rate Categories (Cont'd)
 (A) Local Transport (Cont'd)
 (5) Interface Groups

Four Interface Groups are provided for terminating the Local Transport at the customer's premises.

Each Interface Group provides a specified premises interface (e.g., two-wire, four-wire, DS1, etc.). Where transmission facilities permit, the individual transmission path between the customer's premises and the first point of switching may at the option of the customer be provided with optional features as set forth in (2)(a) and (b) following.

As a consequence of the customer's access order and the type of Telephone Company transport facilities serving the customer's premises, the need for signaling conversions or two-wire to four-wire conversions, or the need to terminate digital or high frequency facilities in channel bank equipment may require that Telephone Company equipment be placed at the customer's premises. For example, if a voice frequency interface is ordered by the customer and the Telephone Company facilities serving the customer's premises are digital, then Telephone Company channel bank equipment must be placed at the customer's premises in order to provide the voice frequency interface ordered by the customer.

Interface Group 1 is provided with Transmission Performance Capability Type C, and Interface Groups 2, 3 and through 6 are provided with Transmission Performance Capability Type A or B, depending on the Feature Group and whether the Access Service is routed directly or through an access tandem. All Interface Groups are provided with Data Transmission Parameters.

Only certain premises interfaces are available at the customer premises. The premises interfaces associated with the Interface Groups may vary among Feature Groups. The various premises interfaces which are available with the Interface Groups, and the Feature Groups with which they may be used, are set forth in (l)(k) following.

Advice No. 03-28

Issued July 23, 2003

Effective August 23, 2003

Issued By CENTURYTEL OF WASHINGTON, INC. d/b/a CenturyTel
 P.O. Box 9901, Vancouver, WA

(C)

By Pamela Donovan Title Supervisor, Tariffs

ACCESS SERVICE

6. Switched Access Service (Cont'd)

6.1 General (Cont'd)

6.1.3 Rate Categories (Cont'd)

(A) Local Transport (Cont'd)

(5) Interface Groups

(a) Interface Group 1 (USOC TPPIX)

Interface Group 1, except as set forth in (b) following, provides two-wire voice frequency transmission at the point of termination at the customer's premises. The interface is capable of transmission of voice and associated telephone signals within the frequency bandwidth of approximately 300 to 3000 Hz.

Interface Group 1 is not provided in association with FGC and FGD when the first point of switching is an access tandem. In addition, Interface Group I is not provided in association with FGB, FGC or FGD when the first point of switching provides only four-wire terminations.

The transmission path between the point of termination at the customer's premises and the first point of switching may be comprised of any form or configuration of plant capable of and typically used in the telecommunications industry for the transmission of voice and associated telephone signals within the frequency bandwidth of 300 to 3000 Hz.

The interface is provided with loop supervisory signaling. When the interface is associated with FGA, such signaling will be loop start or ground start signaling. When the interface is associated with FGB, FGC or FGD, such signaling, except for two-way calling which is E&M signaling, will be reverse battery signaling.

Advice No. 03-28

Issued July 23, 2003

Effective August 23, 2003

Issued By CENTURYTEL OF WASHINGTON, INC. d/b/a CenturyTel
P.O. Box 9901, Vancouver, WA

(C)

By Pamela Donovan Title Supervisor, Tariffs

ACCESS SERVICE

6. Switched Access Service (Cont'd)
6.1 General (Cont'd)
6.1.3 Rate Categories (Cont'd)
(A) Local Transport (Cont'd)
(5) Interface Groups (Cont'd)

(b) Interface Group 2 (USOC TTP2X)

Interface Group 2 provides four-wire voice frequency transmission at the point of termination at the customer's premises. The interface is capable of transmission of voice and associated telephone signals within the frequency bandwidth of approximately 300 to 3000 Hz.

The transmission path between the point of termination at the customer's premises and the first point of switching may be comprised of any form or configuration of plant capable of and typically used in the telecommunications industry for the transmission of voice and associated telephone signals within the frequency bandwidth of approximately 300 to 3000 Hz.

The interface is provided with loop supervisory signaling. When the interface is associated with FGA, such signaling will be loop start or ground start signaling. When the interface is associated with FGB, FGC or FGD, such signaling, except for two-way calling which is E&M signaling, will be reverse battery signaling.

(c) Interface Group 3 (USOC TPP3X)

Interface Group 3 provides group level analog transmission at the point of termination at the customer's premises. The interface is capable of transmitting electrical signals between the frequencies of 60 to 108 kHz, with the capability to channelize up to 12 voice frequency transmission paths. Certain frequencies within the bandwidth of the Interface Group are reserved for Telephone Company use, e.g., pilot and carrier group alarm tones. Before the first point of switching, the Telephone Company will provide multiplex equipment to derive 12 transmission paths of frequency bandwidth of approximately 300 to 3000 Hz.

Advice No. 03-28

Issued July 23, 2003

Effective August 23, 2003

Issued By CENTURYTEL OF WASHINGTON, INC. d/b/a CenturyTel
P.O. Box 9901, Vancouver, WA

(C)

By Pamela Donovan

Title Supervisor, Tariffs

ACCESS SERVICE

6. Switched Access Service (Cont'd)

6.1 General (Cont'd)

6.1.3 Rate Categories (Cont'd)

(A) Local Transport (Cont'd)

(5) Interface Groups (Cont'd)

(e) Available Premises Interface Codes

Following is a matrix showing, for each Interface Group, which customer facility interface codes are available as a function of the Telephone Company switch supervisory signaling and Feature Group. For explanations of these codes, see 7.3 following.

<u>Interface Group</u>	<u>Telephone Company Switch Supervisory Signaling</u>	<u>Premises Facility</u>	<u>Feature Group</u>			
			<u>Interface Code</u>	<u>A</u>	<u>B</u>	<u>C</u>
1	<u>D</u>					
	LO	2LS2	X			
	LO	2LS3	X			
	GO	2GS2	X			
	GO	2GS3	X			
	LO, GO	2DX3	X			
	LO, GO	4EA3-E	X			
	LO, GO	4EA3-M	X			
	LO, GO	6EB3-E	X			
	LO, GO	6EB3-M	X			
	RV, EA, EB, EC	2DX3		X	X	X
	RV, EA, EB, EC	4EA3-E		X	X	X
	RV, EA, EB, EC	4EA3-M		X	X	X
	RV, EA, EB, EC	6EA3-E		X	X	X
	RV, EA, EB, EC	6EB3-M		X	X	X
	EA, EB, EC	6EC3			X	X
	RV	2RV3-O		X	X	X
	RV	2RV3-T		X	X	X
	2	LO, GO	4SF2	X		
		LO, GO	4SF3	X		
LO		4LS2	X			
LO		4LS3	X			
LO		6LS2	X			
GO		4GS2	X			
GO		4GS3	X			
GO		6GS2	X			
LO, GO		4DX2	X			
LO, GO		4DX3	X			
LO, GO		6EA2-E	X			
LO, GO		6EA2-M	X			

Advice No. 03-28

Issued July 23, 2003

Effective August 23, 2003

Issued By CENTURYTEL OF WASHINGTON, INC. d/b/a CenturyTel

P.O. Box 9901, Vancouver, WA

(C)

By Pamela Donovan

Title Supervisor, Tariffs

ACCESS SERVICE

6. Switched Access Service (Cont'd)

6.1 General (Cont'd)

6.1.3 Rate Categories (Cont'd)

(A) Local Transport (Cont'd)

(5) Interface Groups (Cont'd)

(e) Available Premises Interface Codes

Following is a matrix showing, for each Interface Group, which customer facility interface codes are available as a function of the Telephone Company switch supervisory signaling and Feature Group. For explanations of these codes, see 7.3 following.

Interface Group	Telephone Company Switch Supervisory Signaling D	Premises Facility	<u>Feature Group</u>			
			Interface Code	A	B	C
2 (Cont'd)	LO, GO	8EB2-E	X			
	LO, GO	8EB2-M	X			
	LO, GO	6EX2-B	X			
	RV, EA, EB, EC	4SF2		X	X	X
	RV, EA, EB, EC	4SF3	X			
	RV, EA, EB, EC	4DX2		X	X	X
	RV, EA, EB, EC	4DX3		X	X	
	RV, EA, EB, EC	6EA2-E		X	X	X
	RV, EA, EB, EC	6DX2		X	X	
	RV, EA, EB, EC	6EA2-M		X	X	X
	RV, EA, EB, EC	8EB2-E		X	X	X
	RV, EA, EB, EC	8EB2-M		X	X	X
	EA, EB, EC	8EC2-M			X	X
	RV	4RV2-O		X	X	X
	RV	4RV2-T		X	X	X
	RV	4RV3-O	X	X		
	RV	4RV3-T	X	X		
3	LO, GO	4AH5-B	X			
	RV, EA, EB, EC	4AH5-B		X	X	X
6	LO, GO	4DS9-15	X			
	RV, EA, EB, EC	4DS9-15		X	X	X

Advice No. 03-28

Issued July 23, 2003

Effective August 23, 2003

Issued By CENTURYTEL OF WASHINGTON, INC. d/b/a CenturyTel

P.O. Box 9901, Vancouver, WA

(C)

By Pamela Donovan

Title Supervisor, Tariffs

ACCESS SERVICE

6. Switched Access Service (Cont'd)

6.1 General (Cont'd)

6.1.3 Rate Categories (Cont'd)

(A) Local Transport (Cont'd)

(6) Nonchargeable Optional Features

Where transmission facilities permit, the Telephone Company will, at the option of the customer, provide the following nonchargeable optional features in association with Local Transport.

(a) Supervisory Signaling

Where the transmission parameters permit, and where signaling conversion is required by the customer to meet its signaling capability, the customer may order an optional supervisory signaling arrangement for each transmission path provided as follows:

For Interface Groups 1 and 2
DX Supervisory Signaling,
E&M Type I Supervisory Signaling,
E&M Type II Supervisory Signaling, or
E&M Type III Supervisory Signaling

For Interface Group 2
SF Supervisory Signaling, or
Tandem Supervisory Signaling

For Interface Groups 2, 3 and 6
These Interface Groups may, at the option of the customer, be provided with individual transmission path SF supervisory signaling where such signaling is available in Telephone Company central offices. Generally such signaling is available only where the entry switch provides an analog, i.e., non digital, interface to the transport termination.

Advice No. 03-28

Issued July 23, 2003

Effective August 23, 2003

Issued By CENTURYTEL OF WASHINGTON, INC. d/b/a CenturyTel
P.O. Box 9901, Vancouver, WA

(C)

By Pamela Donovan Title Supervisor, Tariffs

ACCESS SERVICE

6. Switched Access Service (Cont'd)

6.1 General (Cont'd)

6.1.3 Rate Categories (Cont'd)

(A) Local Transport (Cont'd)

(6) Nonchargeable Option Features (Cont'd)

(b) Customer Specified Entry Switch Receive Level

This feature allows the customer to specify the receive transmission level at the first point of switching. The range of transmission levels which may be specified is described in Technical Reference PUB 62500. This feature is available with Interface Groups 2, 3 and 6 for Feature Groups A and B. This option allows the customer to specify, for Feature Group B routed directly to an end office or access tandem, a four-wire termination of the Local Transport at the entry switch in lieu of a Telephone Company selected two-wire termination. This option is available only when the Feature Group B arrangement is provided with Type B Transmission Specifications.

Advice No. 03-28

Issued July 23, 2003

Effective August 23, 2003

Issued By CENTURYTEL OF WASHINGTON, INC. d/b/a CenturyTel
P.O. Box 9901, Vancouver, WA

(C)

By Pamela Donovan Title Supervisor, Tariffs

ACCESS SERVICE

6. Switched Access Service (Cont'd)

6.1 General (Cont'd)

6.1.3 Rate Categories (Cont'd)

(C) End Office (Cont'd)

(1) Local Switching (Cont'd)

(a) Common Switching

Common Switching provides the local end office switching functions associated with the various access (i.e., Feature Group) switching arrangements. The Common Switching arrangements provided for the various Feature Group arrangements are described in 6.2 following.

Included as part of the Common Switching are various nonchargeable optional features which the customer can order to meet the customer's specific communications requirements. These optional features are described in 6.3.1 following.

(b) Transport Termination

The Transport Termination provides for the line or trunk side arrangements which terminate the Local Transport facilities. Included as part of Transport Termination are various nonchargeable optional termination arrangements. These optional terminating arrangements are described in 6.3.2 following.

The number of Transport Terminations provided will be determined by the Telephone Company as set forth in 6.5.6 following.

(2) Line Termination

The Line Termination rate element provides the terminations for the end user lines terminating in the local end office. There are two types of Line Terminations, i.e., Common Line Terminations and Dedicated Access Line Terminations.

The Dedicated Access Line Terminations are differentiated by line side vs. trunk side terminations. In addition, there are various types of originating and terminating line side terminations depending on the type of signaling associated with the Dedicated Access Line. Line side terminations are available with either dial pulse or dual tone multifrequency address signaling.

Advice No. 03-28

Issued July 23, 2003

Effective August 23, 2003

Issued By CENTURYTEL OF WASHINGTON, INC. d/b/a CenturyTel
 P.O. Box 9901, Vancouver, WA

(C)

By Pamela Donovan

Title Supervisor, Tariffs

ACCESS SERVICE

6. Switched Access Service (Cont'd)

6.1 General (Cont'd)

6.1.3 Rate Categories (Cont'd)

(C) End Office (Cont'd)

(2) Line Termination (Cont'd)

Line Termination rates are set forth in Sections 16 and 17 following. The application of these rates with respect to individual Feature Groups is as set forth in 6.7.1(D) following.

(3) Intercept

The Intercept rate element provides for the termination of a call at a Telephone Company Intercept operator or recording. The operator or recording tells a caller why a call, as dialed, could not be completed, and if possible, provides the correct number.

Intercept rates are based on usage assessed to a customer based on the total number of access minutes or lines or trunks. Intercept rates are set forth in Sections 16 and 17 following. The application of these rates with respect to individual Feature Groups is as set forth in 6.7.1(D) following.

The number of end office switching transmission paths provided will be determined by the Telephone Company based on the capacity to each end office specified by the customer in its order. The number of transmission paths will be determined as set forth in 6.5.5 following.

Advice No. 03-28

Issued July 23, 2003

Effective August 23, 2003

Issued By CENTURYTEL OF WASHINGTON, INC. d/b/a CenturyTel
P.O. Box 9901, Vancouver, WA

(C)

By Pamela Donovan

Title Supervisor, Tariffs

ACCESS SERVICE

6. Switched Access Service (Cont'd)

6.1 General (Cont'd)

6.1.4 Special Facilities Routing

Any customer may request that the facilities used to provide Switched Access Service be specially routed. The regulations for Special Facilities Routing (i.e., Avoidance, Diversity and Cable- Only) are set forth in 11. following.

6.1.5 Design Layout Report

The Telephone Company will provide to the customer the makeup of the facilities and services provided to the first point of switching. This information will be provided in the form of a Design Layout Report. Design Layout Reports for WATS Access Lines will be provided only when specifically requested by the customer. The Design Layout Report will be provided to the customer at no charge, and will be reissued or updated whenever these facilities are materially changed.

6.1.6 Acceptance Testing

At no additional charge, the Telephone Company will, at the customer's request, cooperatively test, at the time of installation, the following parameters: loss, C-message noise, 3-tone slope, d.c. continuity and operational signaling and C-notched noise. When the Local Transport is provided with an Interface Group 2, and the Transport Termination is two-wire (i.e., there is a four-wire to two-wire conversion in Local Transport), balance parameters (equal level echo path loss) may also be tested. If acceptance tests are not started within 30 minutes after the scheduled appointment time for such tests, as negotiated between the Telephone Company and the customer, additional charges will apply, as set forth in 13.2.6(B) following, unless the delay is caused by the Telephone Company.

6.1.7 Ordering Options and Conditions

Switched Access Service is ordered under the Access Order provisions set forth in 5. preceding. Also, included in that section are other charges which may be associated with ordering Switched Access Service (e.g., Service Data Change Charges, Cancellation Charges, etc.).

Advice No. 03-28

Issued July 23, 2003

Effective August 23, 2003

Issued By CENTURYTEL OF WASHINGTON, INC. d/b/a CenturyTel
P.O. Box 9901, Vancouver, WA

(C)

By Pamela Donovan

Title Supervisor, Tariffs

ACCESS SERVICE

6. Switched Access Service (Cont'd)

6.2 Provision and Description of Switched Access Service Feature Groups

Switched Access Service is provided in four different Feature Group arrangements. The provision of each Feature Group requires Local Transport facilities and the appropriate End Office functions. In addition, a WATS Access Line may, at the option of the customer, be provided with Feature Groups C and D.

There are three specific transmission performances (i.e., Types A, B and C) that have been identified for the provision of Feature Groups. The specific performance provided is dependent on the Interface Group and the routing of the service, i.e., whether the service is routed directly to the end office or via an access tandem. The parameters for the transmission performances are set forth in 6.4.1 following.

Feature Groups are arranged for either originating, terminating or two-way calling, based on the customer end office switching capacity ordered. Originating calling permits the delivery of calls from Telephone Exchange Service locations to the customer's premises. Terminating calling permits the delivery of calls from the customer's premises to Telephone Exchange Service locations. Two-way calling permits the delivery of calls in both directions, but not simultaneously. The Telephone Company will determine the type of calling to be provided unless the customer requests that a different type of directional calling is to be provided. In such cases, the Telephone Company will work cooperatively with the customer to determine the directionality.

There are various nonchargeable optional features available with the Feature Groups. These additional optional features are provided as Local Transport, common Switching or Transport Termination options. Following are detailed descriptions of each of the available Feature Groups. Each Feature Group is described in terms of its specific physical characteristics and calling patterns, the transmission performances with which it is provided, the optional features available for use with it and the standard testing capabilities.

The Common Switching and Transport Termination optional features, which are described in 6.3 following, unless specifically stated otherwise, are available at all Telephone Company end office switches.

Advice No. 03-28

Issued July 23, 2003

Effective August 23, 2003

Issued By CENTURYTEL OF WASHINGTON, INC. d/b/a CenturyTel
P.O. Box 9901, Vancouver, WA

(C)

By Pamela Donovan Title Supervisor, Tariffs

ACCESS SERVICE

6. Switched Access Service (Cont'd)

6.2 Provision and Description of Switched Access Service Feature Groups (Cont'd)

6.2.1 Feature Group A (FGA)

(A) Description

- (1) FGA is provided in connection with Telephone Company electronic and electromechanical end offices. At the option of the customer, FGA is provided on a single or multiple line group basis and is arranged for originating calling only, terminating calling only, or two-way calling.
- (2) FGA provides a line side termination at the first point of switching. The line side termination will be provided with either ground start supervisory signaling or loop start supervisory signaling. The type of signaling is at the option of the customer.
- (3) The Telephone Company shall select the first point of switching, within the selected LATA, at which the line side termination is to be provided unless the customer requests a different first point of switching and Telephone Company facilities and measurement capabilities where necessary are available to accommodate such a request.
- (4) A seven digit local telephone number assigned by the Telephone Company is provided for access to FGA switching in the originating direction. The seven digit local telephone number will be associated with the selected end office switch and is of the form NXX-XXXX.

Advice No. 03-28

Issued July 23, 2003

Effective August 23, 2003

Issued By CENTURYTEL OF WASHINGTON, INC. d/b/a CenturyTel
P.O. Box 9901, Vancouver, WA

(C)

By Pamela Donovan Title Supervisor, Tariffs

ACCESS SERVICE

6. Switched Access Service (Cont'd)
6.2 Provision and Description of Switched Access Service Feature Groups (Cont'd)
6.2.1 Feature Group A (FGA) (Cont'd)
(A) Description (Cont'd)
(4) (Cont'd)

If the customer requests a specific seven digit tele phone number that is not currently assigned, and the Telephone Company can, with reasonable effort, comply with that request, the requested number will be assigned to the customer.

- (5) FGA switching, when used in the terminating direction, is arranged with dial tone start-dial signaling. When used in the terminating direction FGA switching may, at the option of the customer, be arranged for dial pulse or dual tone multifrequency address signaling, subject to availability of equipment at the first point of switching. When FGA switching is provided in a hunt group or uniform call distribution arrangement, all FGA switching will be arranged for the same type of address signaling.
- (6) No address signaling is provided by the Telephone Company when FGA Switching is used in the originating direction. Address signaling in such cases, if required by the customer, must be provided by the customer's end user using inband tone signaling techniques. Such inband tone address signals will not be regenerated by the Telephone Company and will be subject to the ordinary transmission capabilities of the Local Transport provided.

Advice No. 03-28

Issued July 23, 2003

Effective August 23, 2003

Issued By CENTURYTEL OF WASHINGTON, INC. d/b/a CenturyTel
P.O. Box 9901, Vancouver, WA

(C)

By Pamela Donovan

Title Supervisor, Tariffs

ACCESS SERVICE

6. Switched Access Service (Cont'd)

6.2 Provision and Description of Switched Access Service Feature Groups(Cont'd)

6.2.1 Feature Group A (FGA) (Cont'd)

(A) Description (Cont'd)

- (7) FGA switching, when used in the terminating direction, may be used to access valid NXXs in the LATA, local operator service (0- and 0+), Directory Assistance (411 where available and 555-1212), emergency reporting service (911 where available), exchange telephone repair (611 where available), time or weather announcement services of the Telephone Company, community information services of an information service provider, and other customers services (by dialing the appropriate digits). Charges for FGA terminating calls requiring operator assistance or calls to 611 or 911 will only apply where sufficient call details are available. Additional charges will also be billed for (1) an operator surcharge, as set forth in the local exchange tariffs, for local operator assistance (0- and 0+) calls, (2) calls to certain community information services, for which rates are applicable under Telephone Company exchange service tariffs, e.g., 976 (DIAL-IT) Network Services and, (3) customer call charges for use of a customer's service in accordance with the customer's tariff in force when the Telephone Company performs the billing for such customer calls.
- (8) When a FGA switching arrangement for an individual customer (a single line or entire hunt group) is discontinued at an end office, an intercept announcement is provided. This arrangement provides, for a limited period of time, an announcement that the service associated with the number dialed has been disconnected.

Advice No. 03-28

Issued July 23, 2003

Effective August 23, 2003

Issued By CENTURYTEL OF WASHINGTON, INC. d/b/a CenturyTel
P.O. Box 9901, Vancouver, WA

(C)

By Pamela Donovan

Title Supervisor, Tariffs

ACCESS SERVICE

6. Switched Access Service (Cont'd)

6.2 Provision and Description of Switched Access Service Feature Groups(Cont'd)

6.2.1 Feature Group A (FGA) (Cont'd)

(A) Description (Cont'd)

- (9) The definition of Feature Group A Service is modified as follows: FGA Access, when used for MTS/WATS, which provides line side access to Telephone Company end office switches with an associated seven-digit local telephone number for originating communications from and terminating communications to an Interexchange Carrier's Intrastate Service shall only be available to authorized Interexchange Carriers for their use in providing service to their customers. Interexchange Carriers are defined in Section 2.6. See Sections 2.4.8(A)(2) and 6.7 for application of rates.
- (10) Feature Group A, when used as FX or FX ONAL in the terminating direction, may access valid NNX's in the local service area. The description of a specific local service area will be provided to the customer upon request. Calls outside the local service area will incur additional Intrastate toll charges. See Sections 2.4.8(A)(1) and 6.7 for application of rates.

Advice No. 03-28

Issued July 23, 2003

Effective August 23, 2003

Issued By CENTURYTEL OF WASHINGTON, INC. d/b/a CenturyTel
P.O. Box 9901, Vancouver, WA

(C)

By Pamela Donovan

Title Supervisor, Tariffs

ACCESS SERVICE

6. Switched Access Service (Cont'd)
- 6.2 Provision and Description of Switched Access Service Feature Groups (Cont'd)
- 6.2.1 Feature Group A (FGA) (Cont'd)
- (B) Optional Features
- (1) Common Switching Optional Features
- (a) Hunt Group Arrangement
 - (b) Uniform Call Distribution Arrangement
 - (c) Nonhunting Number for Use with Hunt Group Arrangement or Uniform Call Distribution Arrangement
 - (d) Call Denial
 - (e) Service Code Denial
- (2) Transport Termination Optional Features
- (a) Two-way operation with dial pulse address signaling and loop start supervisory signaling
 - (b) Two-way operation with dial pulse address signaling and ground start supervisory signaling
 - (c) Two-way operation with dual tone multifrequency address signaling and loop start supervisory signaling
 - (d) Two-way operation with dual tone multifrequency address signaling and ground start supervisory signaling
 - (e) Terminating operation with dial pulse address signaling and loop start supervisory signaling
 - (f) Terminating operation with dial pulse address signaling and ground start supervisory signaling
 - (g) Terminating operation with dual tone multifrequency address signaling and loop start supervisory signaling
 - (h) Terminating operation with dual tone multifrequency address signaling and ground start supervisory signaling
 - (i) Originating operation with loop start supervisory signaling
 - (j) Originating operation with ground start supervisory signaling

Advice No. 03-28

Issued July 23, 2003

Effective August 23, 2003

Issued By CENTURYTEL OF WASHINGTON, INC. d/b/a CenturyTel
P.O. Box 9901, Vancouver, WA

(C)

By Pamela Donovan Title Supervisor, Tariffs

ACCESS SERVICE

6. Switched Access Service (Cont'd)

6.2 Provision and Description of Switched Access Service Feature Groups (Cont'd)

6.2.1 Feature Group A (FGA) (Cont'd)

(B) Optional Features (Cont'd)

(3) Certain other features which may be available in connection with Feature Group A are provided under the Telephone Company's local and/or general exchange service tariffs. These are:

- (a) Speed Calling
- (b) Remote Call Forwarding
- (c) Bill Number Screening
- (d) IntraLATA extensions

(C) Transmission Performance

FGA is provided with either Type B or Type C Transmission Performance. The parameters associated with these performances are guaranteed to the first point of switching. Type C Transmission Performance is provided with Interface Group 1 and Type B is provided with Interface Groups 2, 3 and 6. Type DB Data Transmission Parameters are provided with FGA to the first point of switching.

(D) Testing Capabilities

FGA is provided, in the terminating direction where equipment is available, with seven digit access to balance (100 type) test line and milliwatt (102 type) test line. In addition to the tests described in 6.1.6 preceding, additional Cooperative Acceptance Testing and Non-Scheduled Testing will be provided for FGA as set forth in 13.3.5. following.

Advice No. 03-28

Issued July 23, 2003

Effective August 23, 2003

Issued By CENTURYTEL OF WASHINGTON, INC. d/b/a CenturyTel
P.O. Box 9901, Vancouver, WA

(C)

By Pamela Donovan Title Supervisor, Tariffs

ACCESS SERVICE

6. Switched Access Service (Cont'd)

6.2 Provision and Description of Switched Access Service Feature Groups (Cont'd)

6.2.2 Feature Group B (FGB)

(A) Description

- (1) FGB, when directly routed to an end office (i.e., provided without the use of an access tandem switch), is provided at appropriately equipped Telephone Company electronic end office switches. When provided via Telephone Company designated electronic access tandem switches, FGB switching is provided at Telephone Company electronic and electromechanical end office switches.
- (2) FGB is provided as trunk side switching through the use of end office or access tandem switch trunk equipment. The switch trunk equipment is provided with wink start start- pulsing signals and answer and disconnect supervisory signaling.
- (3) FGB switching is provided with multifrequency address signaling in both the originating and terminating directions. Except for FGB switching provided with the automatic number identification (ANI) or rotary dial station signaling arrangements as set forth in 6.3 following, any other address signaling in the originating direction, if required by the customer, must be provided by the customer's end user using inband tone signaling techniques. Such inband tone address signals will not be regenerated by the Telephone Company and will be subject to the ordinary transmission capabilities of the Local Transport provided.

Advice No. 03-28

Issued July 23, 2003

Effective August 23, 2003

Issued By CENTURYTEL OF WASHINGTON, INC. d/b/a CenturyTel
P.O. Box 9901, Vancouver, WA

(C)

By Pamela Donovan

Title Supervisor, Tariffs

ACCESS SERVICE

6. Switched Access Service (Cont'd)6.2 Provision and Description of Switched Access Service Feature Groups (Cont'd)6.2.2 Feature Group B (FGB) (Cont'd)(A) Description (Cont'd)

- (4) The access code for FGB switching is a uniform access code. The form of the uniform access code is 950-10XX for carriers. These uniform access codes will be the assigned access numbers of all FGB switched access service provided to the customer by the Telephone Company.
- (5) FGB switching, when used in the terminating direction, may be used to access valid NXXs in the LATA, time or weather announcement services of the Telephone Company, community information services of an information service provider and other customers' services (by dialing the appropriate digits). When directly routed to an end office, only those valid NXX codes served by that end office may be accessed. When routed through an access tandem, only those valid NXX codes served by end offices subtending the access tandem may be accessed. The customer will also be billed additional charges for calls to certain community information services for which rates are applicable under Telephone Company exchange service tariffs, e.g., 976 (DIAL-IT) Network Service. Additionally, non-access charges will also be billed for calls from a FGB trunk to another customer's service in accordance with that customer's applicable service rates when the Telephone Company performs the billing for such customer calls. Calls in the terminating direction will not

Advice No. 03-28

Issued July 23, 2003

Effective August 23, 2003

Issued By CENTURYTEL OF WASHINGTON, INC. d/b/a CenturyTel
P.O. Box 9901, Vancouver, WA

By Pamela Donovan

Title Supervisor, Tariffs

(C)

ACCESS SERVICE

6. Switched Access Service (Cont'd)
- 6.2 Provision and Description of Switched Access Service Feature Groups (Cont'd)
- 6.2.2 Feature Group B (FGB) (Cont'd)
- (A) Description (Cont'd)
- (7) When all FGB switching arrangements are discontinued at an end office and/or in a LATA, an intercept announcement is provided. This arrangement provides, for a limited period of time, an announcement that the service associated with the number dialed has been disconnected.
- (B) Optional Features
- (1) Common Switching Optional Features
- (a) Automatic Number Identification (ANI)
- (b) Up to 7 Digit Outpulsing of Access Digits to Customer
- (2) Transport Termination Optional Features
- (a) Rotary Dial Station Signaling
- (3) Local Transport Optional Features
- (a) Customer Specification of Local Transport Termination
- (b) Supervisory Signaling (as set forth in 6.1.3(B)(3)(a) preceding)
- (c) Customer Specified Entry Switch Receive Level
- (4) Another feature, Bill Number Screening, which may be available in connection with FGB, is provided under the Telephone Company's local and/or general exchange service tariffs.

Advice No. 03-28

Issued July 23, 2003

Effective August 23, 2003

Issued By CENTURYTEL OF WASHINGTON, INC. d/b/a CenturyTel
P.O. Box 9901, Vancouver, WA

(C)

By Pamela Donovan Title Supervisor, Tariffs

ACCESS SERVICE

6. Switched Access Service (Cont'd)
 6.2 Provision and Description of Switched Access Service Feature Groups (Cont'd)
 6.2.2 Feature Group B (FGB) (Cont'd)
 (C) Transmission Performance

FGB is provided with either Type B or Type C Transmission Specifications. The specifications for the associated parameters are guaranteed to the end office when routed directly or to the first point of switching when routed via an access tandem. Type C Transmission Specifications are provided with Interface Group 1 and Type B is provided with Interface Groups 2, 3 and 6. Type DB Data Transmission Parameters are provided with FGB to the first point of switching.

(D) Testing Capabilities

FGB is provided, in the terminating direction where equipment is available, with seven digit access to balance (100 type) test line, milliwatt (102 type) test line, nonsynchronous or synchronous test line, automatic transmission measuring (105 type) test line, data transmission (107 type) test line, loop around test line, short circuit test line and open circuit test line. In addition to the tests described in 6.1.6 preceding, which are included with the installation of service, Additional Cooperative Acceptance Testing, Automatic Scheduled Testing, Cooperative Scheduled Testing, Manual Scheduled Testing and Nonscheduled Testing will be provided as set forth in 13.3.5 following.

6.2.3 Feature Group C (FGC)

(A) Description

- (1) FGC is provided at all Telephone Company end office switches on a direct trunk basis or via Telephone Company designated access tandem switches. FGC switching is provided to the customer (i.e., providers of MTS and WATS) at an end office switch unless Feature Group D end office switching is provided in the same office. When FGD switching is available, FGC switching will not be provided.

Advice No. 03-28

Issued July 23, 2003

Effective August 23, 2003

Issued By CENTURYTEL OF WASHINGTON, INC. d/b/a CenturyTel

P.O. Box 9901, Vancouver, WA

(C)

By Pamela Donovan

Title Supervisor, Tariffs

ACCESS SERVICE

6. Switched Access Service (Cont'd)

6.2 Provision and Description of Switched Access Service Feature Groups (Cont'd)

6.2.3 Feature Group C (FGC) (Cont'd)

(A) Description (Cont'd)

- (2) FGC is provided as trunk side switching through the use of end office or access tandem switch trunk equipment. The switch trunk equipment is provided with answer and disconnect supervisory signaling. Wink start pulsing signals are provided in all offices where available. In those offices where wink start pulsing signals are not available, delay dial start-pulsing signals will be provided, unless immediate dial pulse signaling is provided, in which case no start-pulsing signals are provided.
- (3) FGC is provided with multifrequency address signaling except in certain electromechanical end office switches where multifrequency signaling is not available. In such switches, the address signaling will be dial pulse, revertive pulse, immediate dial pulse or panel call indicator signaling, whichever is available. Up to 12 digits of the called party number dialed by the customer's end user using dual tone multifrequency or dial pulse address signals will be provided by Telephone Company equipment to the customer's premises where the Switched Access Service terminates. Such called party number signals will be subject to the ordinary transmission capabilities of the Local Transport provided.
- (4) No access code is required for FGC switching. The telephone number dialed by the customer's end user shall be a seven or ten digit number for calls in the North American Numbering Plan (NANP).

Advice No. 03-28

Issued July 23, 2003

Effective August 23, 2003

Issued By CENTURYTEL OF WASHINGTON, INC. d/b/a CenturyTel

P.O. Box 9901, Vancouver, WA

(C)

By Pamela Donovan

Title Supervisor, Tariffs

ACCESS SERVICE

6. Switched Access Service (Cont'd)

6.2 Provision and Description of Switched Access Service Feature Groups (Cont'd)

6.2.3 Feature Group C (FGC) (Cont'd)

(A) Description (Cont'd)

- (5) FGC switching, when used in the terminating direction, may be used to access valid NXXs in the LATA, time or weather announcement services of the Telephone Company, community information services of an information provider, and other customers' services (by dialing the appropriate codes) when the services can be reached using valid NXX codes. When directly routed to an end office, only those valid NXX codes served by that office may be accessed. When routed through an access tandem, only those valid NXX codes served by offices subtending the access tandem may be accessed. Where measurement capabilities exist, the customer will also be billed additional charges for calls to certain community information services, for which rates are applicable under Telephone Company exchange service tariffs, e.g., 976 (DIAL-IT) Network Services. Additionally, non-access charges will also be billed for calls from a FGC trunk to another customer's service in accordance with that customer's service rates when the Telephone Company performs the billing function for the customer. Calls in the terminating direction will not be completed to 950-10XX access codes, local operator assistance (0- and 0+), service codes (611 and 911 where available) and 10XXX access codes. Calls will be completed to Directory Assistance (411 where available and 555- 1212) when FGC switching is combined with Directory Assistance switching. FGC may not be switched, in the terminating direction, to Switched Access Service Feature Groups B, C or D.
- (6) The Telephone Company will establish a trunk group or groups for the customer at end office switches or access tandem switches where FGC switching is provided. When required by technical limitations, a separate trunk group will be established for each type of FGC switching arrangement provided. Different types of FGC or other switching arrangements may be combined in a single trunk group at the option of the Telephone Company.

Advice No. 03-28

Issued July 23, 2003

Effective August 23, 2003

Issued By CENTURYTEL OF WASHINGTON, INC. d/b/a CenturyTel
P.O. Box 9901, Vancouver, WA

(C)

By Pamela Donovan Title Supervisor, Tariffs

ACCESS SERVICE

6. Switched Access Service (Cont'd)
- 6.2 Provision and Description of Switched Access Service Feature Groups (Cont'd)
- 6.2.3 Feature Group C (FGC) (Cont'd)
- (B) Optional Features
- (1) Common Switching Optional Features
- (a) Automatic Number Identification (ANI)
 - (b) Service Class Routing
 - (c) Dial Pulse Address Signaling
 - (d) Revertive Pulse Address Signaling
 - (e) Delay Dial Start-Pulsing Signaling
 - (f) Immediate Dial Pulse Address Signaling
 - (g) Panel Call Indicator Address Signaling
 - (h) Alternate Traffic Routing
 - (i) Trunk Access Limitation
 - (j) End Office End User Line Service Screening for Use with Special Access Dedicated Access Lines
 - (k) Hunt Group Arrangement for Use with Dedicated Access Lines
 - (l) Uniform Call Distribution Arrangement for Use with Special Access Dedicated Access Lines
 - (m) Nonhunting Number for Use with Hunt Group Arrangement or Uniform Call Distribution Arrangement for Use with Special Access Dedicated Access Lines
 - (n) Band Advance Arrangement for Use with Special Access Dedicated Access Lines
- (2) Transport Termination Optional Features
- (a) Operator Trunks - i.e., Coin, Non-Coin and Combined Coin and Non-Coin. (Non-Coin Trunks are provided at Telephone Company electronic and electromechanical end offices. Coin and Combined Coin and Non-Coin are provided only at Telephone Company electronic end offices and other Telephone Company end offices where equipment is available.)

Advice No. 03-28

Issued July 23, 2003

Effective August 23, 2003

Issued By CENTURYTEL OF WASHINGTON, INC. d/b/a CenturyTel
P.O. Box 9901, Vancouver, WA

(C)

By Pamela Donovan Title Supervisor, Tariffs

ACCESS SERVICE

6. Switched Access Service (Cont'd)
6.2 Provision and Description of Switched Access Service Feature Groups (Cont'd)
6.2.3 Feature Group C (FGC) (Cont'd)
(C) Transmission Specifications

FGC is provided with either Type B or Type C Transmission Specifications as follows:

When routed directly to the end office either Type B or Type C is provided.

When routed to an access tandem only Type B is provided.

Type B or Type C is provided on the transmission path from the access tandem to the end office.

Type C Transmission Specifications are provided with Interface Group 1 when routed directly to an end office. Type B is Provided with Interface Groups 2, 3 and 6, whether routed directly to an end office or to an access tandem.

Type DB Data Transmission Parameters are provided with FGC for the transmission path between the customer's premises and the end office when directly routed to the end office, and Type DB Data Transmission Parameters are provided for the transmission path between the customer's premises and the access tandem and between the access tandem and the end office when routed via an access tandem.

Advice No. 03-28

Issued July 23, 2003

Effective August 23, 2003

Issued By CENTURYTEL OF WASHINGTON, INC. d/b/a CenturyTel
P.O. Box 9901, Vancouver, WA

(C)

By Pamela Donovan

Title Supervisor, Tariffs

ACCESS SERVICE

6. Switched Access Service (Cont'd)
 6.2 Provision and Description of Switched Access Service Feature Groups (Cont'd)
 6.2.3 Feature Group C (FGC) (Cont'd)
 (D) Testing Capabilities

FGC is provided, in the terminating direction where equipment is available, with seven digit access to balance (100 type) test line, milliwatt (102 type) test line, nonsynchronous or synchronous test line, automatic transmission measuring (105 type) test line, data transmission (107 type) test line, loop around test line, short circuit test line and open circuit test line. In addition to the tests described in 6.1.6 preceding which are included with the installation of service, additional Cooperative Acceptance Testing, non-optional Automatic Scheduled Testing, Cooperative Scheduled Testing or Manual Scheduled Testing, and Nonscheduled Testing will be provided as set forth in 13.3.5 following for FGC.

- 6.2.4 Feature Group D (FGD)
 (A) Description

- (1) FGD and Dialing Parity will be provided where technologically and economically practical at Telephone Company designated electronic end office switches whether routed directly or via Telephone Company designated electronic access tandem switches. Provision of FGD services, when not available upon customer request, will be under the guidelines set by the Federal Communications Commission in Docket 78-72, Phase III, Order 86-4 released January 8, 1986 and in Docket 96-98 Second Report and Order released August 8, 1996.
- (2) FGD is provided as trunk side switching through the use of end office or access tandem switch trunk equipment. The switch trunk equipment is provided with wink start start-pulsing signals and answer and disconnect supervisory signaling.
- (3) FGD switching is provided with multifrequency address signaling. Up to 12 digits of the called party number dialed by the customer's end user using dual tone multifrequency or dial pulse address signals will be provided by Telephone Company equipment to the customer's premises where the Switched Access Service terminates. Such address signals will be subject to the ordinary transmission capabilities of the Local Transport provided.
- (4) FGD switching, when used in the terminating direction, may be used to access valid NXXs in the LATA, time or weather announcement services of the Telephone Company, community

Advice No. 03-28

Issued July 23, 2003

Effective August 23, 2003

Issued By CENTURYTEL OF WASHINGTON, INC. d/b/a CenturyTel
 P.O. Box 9901, Vancouver, WA
 By Pamela Donovan Title Supervisor, Tariffs

(C)

ACCESS SERVICE

6. Switched Access Service (Cont'd)

6.2 Provision and Description of Switched Access Service Feature Groups (Cont'd)

6.2.4 Feature Group D (FGD) (Cont'd)

(A) Description (Cont'd)

- (5) The Telephone Company will establish a trunk group or groups for the customer at end office switches or access tandem switches where FGD switching is provided. When required by technical limitations, a separate trunk group will be established for each type of FGD switching arrangement provided. Different types of FGD or other switching arrangements may be combined in a single trunk group at the option of the Telephone Company.
- (6) The access code for FGD switching is a uniform access code of the form 10XXX. A single access code will be the assigned number of all FGD access provided to the customer by the Telephone Company. No access code is required for calls to a customer over FGD Switched Access Service if the end user's telephone exchange service is arranged for presubscription to that customer, as set forth in I3. following.

Advice No. 03-28

Issued July 23, 2003

Effective August 23, 2003

Issued By CENTURYTEL OF WASHINGTON, INC. d/b/a CenturyTel
P.O. Box 9901, Vancouver, WA

(C)

By Pamela Donovan Title Supervisor, Tariffs

ACCESS SERVICE

6. Switched Access Service (Cont'd)

6.2 Provision and Description of Switched Access Service Feature Groups (Cont'd)

6.2.4 Feature Group D (FGD) (Cont'd)

(B) Optional Features

(1) Common Switching Optional Features

- (a) Automatic Number Identification (ANI)
- (b) Service Class Routing
- (c) Alternate Traffic Routing
- (d) Call Gapping Arrangement
- (e) Trunk Access Limitation
- (f) End Office Customer Line Service Screening for Use with Special Access Dedicated Access Line Service
- (g) Hunt Group Arrangement for Use with Special Access Dedicated Access Lines
- (h) Uniform Call Distribution Arrangement for Use with Special Access Dedicated Access Line Service
- (i) Nonhunting Number for Use with Hunt Group Arrangement or Uniform Call Distribution Arrangement for Use with Special Access Dedicated Access Lines
- (j) Band Advance Arrangement for Use with Special Access Dedicated Access Lines

(2) Transport Termination Optional Features

- (a) Operator Trunks, Full Feature Arrangement

(3) Dedicated Access Lines

(C) Transmission Specifications

FGD is provided with either Type A, Type B or Type C Transmission Performance as follows:

When routed directly to the end office either Type B or Type C is provided.

Advice No. 03-28

Issued July 23, 2003

Effective August 23, 2003

Issued By CENTURYTEL OF WASHINGTON, INC. d/b/a CenturyTel
P.O. Box 9901, Vancouver, WA

(C)

By Pamela Donovan Title Supervisor, Tariffs

ACCESS SERVICE

6. Switched Access Service (Cont'd)
6.2 Provision and Description of Switched Access Service Feature Groups (Cont'd)
6.2.4 Feature Group D (FGD) (Cont'd)
(C) Transmission Specification (Cont'd)

When routed to an access tandem only Type A is provided.

Type A is provided on the transmission path from the access tandem to the end office.

Type C Transmission Specification is provided with Interface Group 1. Type A and Type B

Transmission Specifications are provided with Interface Groups 2, 3 and 6.

Type DA Data Transmission Parameters are provided for the transmission path between the premises and the access tandem and between the access tandem and the end office. Type DB Data Transmission Parameters are provided with FGD for the transmission path between the premises and the end office when directly routed to the end office.

(D) Testing Capabilities

FGD is provided, in the terminating direction where equipment is available, with seven digit access to balance (100 type) test line, milliwatt (102 type) test line, nonsynchronous or synchronous test line, automatic transmission measuring (105 type) test line, data transmission (107 type) test line, loop around test line, short circuit test line and open circuit test line. In addition to the tests described in 6.1.6 preceding, which are included with the installation of the service, additional Cooperative Acceptance Testing, non-optional Automatic Scheduled Testing, Cooperative Scheduled Testing, or Manual Scheduled Testing, and Non-Scheduled Testing, are available for FGD as set forth in 13.3.5 following.

Advice No. 03-28

Issued July 23, 2003

Effective August 23, 2003

Issued By CENTURYTEL OF WASHINGTON, INC. d/b/a CenturyTel
P.O. Box 9901, Vancouver, WA

(C)

By Pamela Donovan

Title Supervisor, Tariffs

ACCESS SERVICE

6. Switched Access Service (Cont'd)
6.2 Provision and Description of Switched Access Service Feature Groups (Cont'd)
6.2.5 800 Access Service

800 Access Service is an originating service utilizing trunk-side switched Access Service that may be provided via 800 Access service trunk groups, or may be provided in conjunction with FGD. The service provides for the forwarding of end user dialed 800 calls to a Telephone Company Service Switching Point (SSP) which will initiate an 800 data base query to the Telephone Company's 800 data base to perform the customer identification function. The call is forwarded to the appropriate customer based on the dialed 800 number.

No Access code is required for 800 Access Service. When the 800 call is originated by an end user, the Telephone Company will perform the 800 data base query based on the dialed digits to determine the customer location to which the call is to be routed. The 800 data base query will be performed from suitably equipped end offices or access tandems. If the call originates from an end office not equipped to perform the 800 data base query, the call will be routed to an access tandem at which the query function is available. Once customer identification has been established, the call will be routed to the customer. 800 calls may be routed to different customers based on the local access transport area in which the call originates; however, calls originating from an end office switch not included in the customer's area of service for 800 Access Service will not be completed.

Advice No. 03-28

Issued July 23, 2003

Effective August 23, 2003

Issued By CENTURYTEL OF WASHINGTON, INC. d/b/a CenturyTel
P.O. Box 9901, Vancouver, WA

(C)

By Pamela Donovan Title Supervisor, Tariffs

ACCESS SERVICE

6. Switched Access Service (Cont'd)

6.3 Common Switching and Transport Termination Nonchargeable Optional Features

Following are descriptions of the various optional features that are available in lieu of, or in addition to, the standard features provided with the Feature Groups. They are provided as either Common Switching or Transport Termination options.

6.3.1 Common Switching Optional Features

(A) Call Denial on Line or Hunt Group

This option allows for the screening of terminating calls within the LATA, and for the completion only of calls to 411, 611, 911, 800, 555-1212, and a Telephone Company specified set of NXXs within the Telephone Company local exchange calling area of the dial tone office in which the arrangement is provided. All other "toll" calls are routed to a reorder tone or recorded announcement. This feature is provided in all Telephone Company electronic end offices and, where available, in electromechanical end offices. It is available with Feature Group A.

(B) Service Code Denial on Line or Hunt Group

This option allows for the screening of terminating calls within the LATA, and for disallowing completion of calls to 0-, 555 and N11 (e.g., 411, 611, and 911). This feature is provided where available in all Telephone Company electronic end offices and electromechanical end offices. It is available with Feature Group A.

(C) Hunt Group Arrangement

This option provides the ability to sequentially access one of two or more line side connections in the originating direction, when the access code of the line group is dialed. This feature is provided in all Telephone Company end offices. It is available with Feature Group A.

(D) Uniform Call Distribution Arrangement

This option provides a type of multiline hunting arrangement which provides for an even distribution of calls among the available lines in a hunt group. Where available, this feature is provided in Telephone Company electronic end offices only. It is available with Feature Group A.

Advice No. 03-28

Issued July 23, 2003

Effective August 23, 2003

Issued By CENTURYTEL OF WASHINGTON, INC. d/b/a CenturyTel

P.O. Box 9901, Vancouver, WA

(C)

By Pamela Donovan

Title Supervisor, Tariffs

ACCESS SERVICE

6. Switched Access Service (Cont'd)
6.3 Common Switching and Transport Termination Nonchargeable Optional Features
(Cont'd)
6.3.1 Common Switching Optional Features (Cont'd)

(E) Nonhunting Number for Use with Hunt Group or Uniform Call Distribution Arrangement

This option provides an arrangement for an individual line within a multiline hunt or uniform call distribution group that provides access to that line within the hunt or uniform call distribution group when it is idle or provides busy tone when it is busy, when the nonhunting number is dialed. Where available, this feature is provided in Telephone Company electronic end offices only. It is available with Feature Group A.

(F) Automatic Number Identification (ANI)

This option provides the automatic transmission of a seven or ten digit number and information digits to the customer's premises for calls originating in the LATA, to identify the calling station. The ANI feature is an end office software function which is associated on a call-by-call basis with (1) all individual transmission paths in a trunk group routed directly between an end office and a customer's premises or, where technically feasible, with (2) all individual transmission paths in a trunk group between an end office and an access tandem, and a trunk group between an access tandem and a customer's premises.

The seven digit ANI telephone number is available with Feature Groups B and C. With these Feature Groups, technical limitations may exist in Telephone Company switching facilities which require ANI to be provided only on a directly trunked basis. ANI will be transmitted on all calls except those originating from multiparty lines, coin stations and coinless pay telephones using Feature Group B, or when an ANI failure has occurred.

The ten digit ANI telephone number is only available with Feature Group D. The ten digit ANI telephone number consists of the Numbering Plan Area (NPA) plus the seven digit ANI telephone number. The ten digit ANI telephone number will be transmitted

Advice No. 03-28

Issued July 23, 2003

Effective August 23, 2003

Issued By CENTURYTEL OF WASHINGTON, INC. d/b/a CenturyTel
P.O. Box 9901, Vancouver, WA

(C)

By Pamela Donovan Title Supervisor, Tariffs

ACCESS SERVICE

6. Switched Access Service (Cont'd)
6.3 Common Switching and Transport Termination Nonchargeable Optional Features
(Cont'd)
6.3.1 Common Switching Optional Features (Cont'd)
(F) Automatic Number Identification (ANI) (Cont'd)

on all calls except those identified as multiparty line or ANI failure, in which case only the NPA will be transmitted (in addition to the information digit described below).

With Feature Group C, ANI is provided from end offices at which Telephone Company recording for end user billing is not provided, or where it is not required. It is not provided from end offices for which the Telephone Company needs to forward ANI to its recording equipment.

Where ANI cannot be provided, e.g., on calls from 4 and 8 party services, information digits will be provided to the customer.

The information digits identify: (1) telephone number is the station billing number - no special treatment required, (2) multiparty line - telephone number is a 4- or 8-party line and cannot be identified - number must be obtained via an operator or in some other manner, (3) ANI failure has occurred in the end office switch which prevents identification of calling telephone number - must be obtained by operator or in some other manner, (4) hotel/motel originated call which requires room number identification, (5) coinless station, hospital, inmate, etc, call which requires special screening or handling by the customer, and (6) call is an Automatic Identified Outward Dialed (AIOD) call from customer premises equipment. The ANI telephone number is the listed telephone number of the customer and is not the telephone number of the called party.

Advice No. 03-28

Issued July 23, 2003

Effective August 23, 2003

Issued By CENTURYTEL OF WASHINGTON, INC. d/b/a CenturyTel
P.O. Box 9901, Vancouver, WA

(C)

By Pamela Donovan

Title Supervisor, Tariffs

ACCESS SERVICE

6. Switched Access Service (Cont'd)
6.3 Common Switching and Transport Termination Nonchargeable Optional Features (Cont'd)
6.3.1 Common Switching Optional Features (Cont'd)

(N) Trunk Access Limitation

This option provides for the routing of originating 900 service calls to a specified number of transmission paths in a trunk group, in order to limit (choke) the completion of such traffic to the customer. Calls to the designated service which could not be completed over the subset of transmission paths in the trunk group, i.e., the choked calls, would be routed to reorder tone. It is provided in all Telephone Company electronic end offices and where available in electromechanical end offices. It is available with Feature Groups C and D.

(O) Call Gapping Arrangement

This option, provided in suitably equipped end office switches, provides for the routing of originating calls to 900 service to be switched in the end office to all transmission paths in a trunk group at a prescribed rate of flow, e.g., one call every five seconds, in order to limit (choke) the completion of such traffic to the customer. Calls to the designated service which are denied access by this feature, i.e., the choked calls, would be routed to a no-circuit announcement. It is provided in selected Feature Group D equipped end offices and is available only with Feature Group D.

(P)

(Q)

Advice No. 03-28

Issued July 23, 2003

Effective August 23, 2003

Issued By CENTURYTEL OF WASHINGTON, INC. d/b/a CenturyTel
P.O. Box 9901, Vancouver, WA

(C)

By Pamela Donovan

Title Supervisor, Tariffs

ACCESS SERVICE

6. Switched Access Service (Cont'd)
 6.3 Common Switching and Transport Termination Nonchargeable Optional Features
 (Cont'd)
 6.3.1 Common Switching Optional Features (Cont'd)

(R) Band Advance Arrangement for Use with Dedicated Access Lines

This option, which is provided in association with two or more Dedicated Access Line Service (DALs) groups, provides for the automatic overflow of terminating calls to a DALs group, when that group has exceeded its call capacity, to another DALs group with a band designation equal to or greater than that of the overflowing DALs group. This arrangement does not provide for call overflow from a group with a higher band designation to one with a lower one. This option is available with Feature Groups C and D.

(S) End Office End User Line Service Screening for Use with Dedicated Access Lines

This option provides the ability to verify that an end user has dialed a called party address (by screening the called NPA and/or NXX on the basis of geographical bands selected by the Telephone Company) which is in accordance with that end user's service agreement with the customer, e.g., WATS. This option is provided in all Telephone Company electronic end offices and, where available, in electromechanical end offices in which WATS Access Lines are provided. It is available with Feature Groups C and D.

(T) Hunt Group Arrangement for Use with Dedicated Access Lines

This option provides the ability to sequentially access one of two or more Dedicated Access Lines (e.g., 800 Service access lines) in the terminating direction, when the hunting number of the Dedicated Access Line Service group is forwarded from the customer to the Telephone Company. This feature is provided in all Telephone Company end offices in which Dedicated Access Lines are provided. It is available with Feature Groups C and D.

Advice No. 03-28

Issued July 23, 2003

Effective August 23, 2003

Issued By CENTURYTEL OF WASHINGTON, INC. d/b/a CenturyTel
 P.O. Box 9901, Vancouver, WA

(C)

By Pamela Donovan Title Supervisor, Tariffs

ACCESS SERVICE

6. Switched Access Service (Cont'd)6.3 Common Switching and Transport Termination Nonchargeable Optional Features
(Cont'd)6.3.1 Common Switching Optional Features (Cont'd)(U) Uniform Call Distribution Arrangement for Use with Dedicated Access Lines

This option provides a type of multiline hunting arrangement which provides for an even distribution of terminating calls among the available Dedicated Access Lines in the hunt group. Where available, this feature is only provided in Telephone Company electronic end offices in which Switched Access Lines are provided. It is available with Feature Groups C and D.

(V) Nonhunting Number for Use with Hunt Group Arrangement or Uniform Call Distribution

Arrangement for Use with Dedicated Access Lines This option provides an arrangement for an individual Dedicated Access Lines within a multiline hunt or uniform call distribution group that provides access to that Dedicated Access Lines within the hunt or uniform call distribution group when it is idle or provides busy tone when it is busy, when the nonhunting number is dialed. Where available, this feature is only provided in Telephone Company electronic end offices in which Dedicated Access Lines are provided. It is available with Feature Groups C and D.

6.3.2 Termination Optional Features(A) Rotary Dial Station Signaling

This option provides for the transmission of called party address signaling from rotary dial stations to the customer's premises for originating calls. This option is provided in the form of a specific type of Transport Termination. It is available with Feature Group B, only on a directly trunked basis.

Advice No. 03-28

Issued July 23, 2003

Effective August 23, 2003

Issued By CENTURYTEL OF WASHINGTON, INC. d/b/a CenturyTel
P.O. Box 9901, Vancouver, WA

(C)

By Pamela Donovan

Title Supervisor, Tariffs

ACCESS SERVICE

6. Switched Access Service (Cont'd)
 6.3 Common Switching and Transport Termination Nonchargeable Optional Features
 (Cont'd)
 6.3.2 Transport Termination Optional Features (Cont'd)
 (B) Operator Trunk - Coin, Non-Coin, or Combined Coin and Non-Coin (Cont'd)

Non-Coin: (Cont'd)

The operator assistance non-coin calling arrangement is also normally ordered by the customer in conjunction with the ANI optional feature, since the preponderance of trunk groups equipped with this arrangement will be terminated in the customer's TSPS systems, rather than in the customer's manual cord boards. When so equipped, the ANI feature provides for the forwarding of information digits which identify that the call has originated from a hotel or motel, and whether room number identification is required, or that special screening is required, e.g., for coinless public stations, dormitory or inmate stations, or other screening arrangements agreed to between the customer and the Telephone Company.

Combined Coin and Non-Coin:

This arrangement provides for initial coin return control and routing of 0+, 0-, 1+, 01+ or 011+ prefixed originating operator assisted coin and non-coin calls requiring operator assistance to the customer's premises. Because operator assisted coin and non-coin calling traffic is routed over a trunk group dedicated to operator assisted calls, this arrangement is only provided in association with the Service Class Routing option.

This arrangement is normally ordered by the customer in conjunction with the ANI optional feature, since the preponderance of trunk groups equipped with this arrangement will be terminated in the customer's operator services systems, rather than in the customer's manual cord boards. When so equipped, the ANI optional feature provides for the forwarding of information digits which identify that the call has originated from a hotel or motel, and whether room number identification is required, or that special screening is required, e.g., for coinless public stations, dormitory or inmate stations, or other screening arrangements agreed to between the customer and the Telephone Company.

Advice No. 03-28

Issued July 23, 2003

Effective August 23, 2003

Issued By CENTURYTEL OF WASHINGTON, INC. d/b/a CenturyTel
 P.O. Box 9901, Vancouver, WA

(C)

By Pamela Donovan Title Supervisor, Tariffs

ACCESS SERVICE

6. Switched Access Service (Cont'd)

6.4 Transmission Performance Specifications

Each Switched Access Service transmission path is provided with a standard transmission performance. There are three different standard performances (Types A, B and C). The standard for a particular transmission path is dependent on the Feature Group, the Interface Group and whether the service is directly routed or via an access tandem. In addition, the Dedicated Access Line is provided with standard transmission performance for two-wire and four-wire. The available transmission performances are set forth in 6.4.1 following. Data Transmission Parameters are also provided with each Dedicated Access Service transmission path and Dedicated Access Line. The Telephone Company will, upon notification by the customer that the data parameters set forth in 6.4.2(A), 6.4.2(B) or 6.4.2(C) are not being met, conduct tests independently or in cooperation with the customer, and take any necessary action to insure that the data parameters are met. The testing will be charged for at the rates set forth in Sections 16, 17 and 18 following for Nonscheduled Testing, unless the testing determines that data parameters are not being met by Telephone Company facilities, in which case no charge applies.

In addition, the Dedicated Access Line may be optionally provided with Improved Two-Wire Voice Transmission Specifications as forth in 6.4.3 following.

The Telephone Company will maintain existing transmission specifications on functioning service configurations installed prior to the effective date of this tariff. Service configurations having performance specifications exceeding the standards listed in this provision will be maintained at the performance levels specified in this tariff.

The transmission specifications contained in this Section are immediate action limits. Acceptance and Maintenance limits are set forth in Technical Reference PUB 62500. This Technical Reference also provides the basis for determining Switched Access Service maintenance limits.

Advice No. 03-28

Issued July 23, 2003

Effective August 23, 2003

Issued By CENTURYTEL OF WASHINGTON, INC. d/b/a CenturyTel
 P.O. Box 9901, Vancouver, WA

(C)

By Pamela Donovan Title Supervisor, Tariffs

ACCESS SERVICE

6. Switched Access Service (Cont'd)
6.4 Transmission Performance Specifications (Cont'd)
6.4.1 Standard Transmission Specifications

Following are descriptions of the three Standard Transmission Specifications available with Switched Access Service Feature Groups and the two Standard Transmission Specifications for WATS Switched Access Service. Their specific applications in terms of the Feature Groups and Interface Groups with which the Feature Group Standard Transmission Specifications are provided are set forth in 6.2.1(C), 6.2.2(C), 6.2.3(C) and 6.2.4(C) preceding.

- (A) Transmission Performance Type A
Transmission Performance Type A is provided with the following parameters:

- (1) Loss Deviation

The maximum Loss Deviation of the 1004 Hz loss relative to the Expected Measured Loss (EML) is ± 2.0 dB

Advice No. 03-28

Issued July 23, 2003 Effective August 23, 2003
Issued By CENTURYTEL OF WASHINGTON, INC. d/b/a CenturyTel
 P.O. Box 9901, Vancouver, WA
By Pamela Donovan Title Supervisor, Tariffs

(C)

ACCESS SERVICE

- 6. Switched Access Service (Cont'd)
 - 6.4 Transmission Specifications
 - 6.4.1 Standard Transmission Specifications (Cont'd)
 - (A) Type A Transmission Specifications (Cont'd)

- (2) Attenuation Distortion

The maximum Attenuation Distortion in the 404 to 2804 Hz frequency band relative to the loss at 1004 Hz is -1.0 dB to +3.0 dB.

- (3) -Message Noise

The maximum C-Message Noise for the transmission path at the route miles listed is less than or equal to:

<u>Route Miles</u>	<u>C-Message Noise</u>
less than 50	32 dBrnCO
51 to 100	34 dBrnCO
101 to 200	37 dBrnCO
201 to 400	40 dBrnCO
401 to 1000	42 dBrnCO

- (4) -Notch Noise

The maximum C-Notch Noise, utilizing a -16 dBmO holding tone, is less than or equal to 45 dBrnCO.

- (5) Echo Control

Echo Control, identified as Equal Level Echo Path Loss, and expressed as Echo Return Loss and Singing Return Loss, is dependent on the routing, i.e., whether the service is routed directly from the customer's Point of Termination (POT) to the end office or via an access tandem. It is equal to or greater than the following:

<u>Loss</u>	<u>Echo Return Loss</u>	<u>Singing Return</u>
POT to Access Tandem	21 dB	14 dB
POT to End office		
- Direct	N/A	N/A
- Via Access Tandem	16 dB	11 dB

Advice No. 03-28

Issued July 23, 2003

Effective August 23, 2003

Issued By CENTURYTEL OF WASHINGTON, INC. d/b/a CenturyTel

P.O. Box 9901, Vancouver, WA

(C)

By Pamela Donovan

Title Supervisor, Tariffs

ACCESS SERVICE

6. Switched Access Service (Cont'd)
6.4 Transmission Specification (Cont'd)
6.4.1 Standard Transmission Specifications (Cont'd)
(A) Type A Transmission Specifications (Cont'd)
(6) Standard Return Loss

Standard Return Loss expressed as Echo Return Loss and Singing Return Loss on two-wire ports of a four-wire point of interface shall be equal to or greater than:

<u>Echo Return Loss</u>	<u>Singing Return Loss</u>
5 dB	2.5 dB

- (B) Type B Transmission Performance Specifications

Type B Transmission Specifications are provided with the following parameters:

- (1) Loss Deviation

The maximum Loss Deviation of the 1004 Hz loss relative to the Expected Measured Loss (EML) is ± 2.5 dB.

- (2) Attenuation Distortion

The maximum Attenuation Distortion in the 404 to 2804 Hz frequency band relative to loss at 1004 Hz is -2.0 dB to +4.0 dB.

- (3) C-Message Noise

The maximum C-Message Noise for the transmission path at the route miles listed is less than or equal to:

Advice No. 03-28

Issued July 23, 2003

Effective August 23, 2003

Issued By CENTURYTEL OF WASHINGTON, INC. d/b/a CenturyTel
P.O. Box 9901, Vancouver, WA

(C)

By Pamela Donovan Title Supervisor, Tariffs

ACCESS SERVICE

- 6 Switched Access Service (Cont'd)
 6.4 Transmission Specifications (Cont'd)
 6.4.1 Standard Transmission Specifications (Cont'd)
 (B) Type B Transmission Specifications (Cont'd)
 (3) C-Message Noise (Cont'd)

Route Miles	<u>C-Message Noise*</u>	
	<u>Type B1</u>	<u>Type B2</u>
less than 50	32 dBrnCO	35 dBrnCO
51 to 100	33 dBrnCO	37 dBrnCO
101 to 200	35 dBrnCO	40 dBrnCO
201 to 400	37 dBrnCO	43 dBrnCO
401 to 1000	39 dBrnCO	45 dBrnCO

- (4) C-Notch Noise

The maximum C-Notch Noise, utilizing a -16 dBmO holding tone is less than or equal to 47 dBrnCO.

- (5) Echo Control

Echo Control, identified as Impedance Balance for FGA and FGB and Equal Level Echo Path Loss for FGC and FGD, and expressed as Echo Return Loss (ERL) and Singing Return Loss (SRL), is dependent on the routing, i.e., whether the service is routed directly from the customer's Point of Termination (POT) to the end office or via an access

* For Feature Groups C and D only, Type B2 will be provided. For Feature Groups A and B, Type B1 or B2 will be provided where suitable Telephone Company facilities are available.

Advice No. 03-28

Issued July 23, 2003

Effective August 23, 2003

Issued By CENTURYTEL OF WASHINGTON, INC. d/b/a CenturyTel
 P.O. Box 9901, Vancouver, WA

(C)

By Pamela Donovan Title Supervisor, Tariffs

ACCESS SERVICE

6. Switched Access Service (Cont'd)
 6.4 Transmission Specifications (Cont'd)
 6.4.1 Standard Transmission Specifications (Cont'd)
 (B) Type B Transmission Specifications (Cont'd)
 (5) Echo Control (Cont'd)

tandem. The ERL and SRL also differ by Feature Group, type of termination, and type of transmission path. They are greater than or equal to the following:

<u>Loss</u>	<u>Echo Return Loss</u>	<u>Singing Return</u>
POT to Access Tandem		
- Terminated in 4-Wire Trunk	21 dB	14 dB
- Terminated in 2-Wire Trunk	16 dB	11 dB
POT to End Office		
- Direct	16 dB	11 dB
- Via Access Tandem		
-.For FGB access		
(Effective 4-Wire		
transmission path at		
end office)	16 dB	11 dB
- For FGC access		
(Effective 2-Wire		
transmission path at		
end office)	13 dB	6 dB

(6) Standard Return Loss

Standard Return Loss, expressed as Echo Return Loss and Singing Return Loss, on two-wire ports of a four-wire point of termination shall be equal to or greater than:

<u>Loss</u>	<u>Echo Return Loss</u>	<u>Singing Return</u>
	5 dB	2.5 dB

Advice No. 03-28

Issued July 23, 2003

Effective August 23, 2003

Issued By CENTURYTEL OF WASHINGTON, INC. d/b/a CenturyTel
 P.O. Box 9901, Vancouver, WA

(C)

By Pamela Donovan Title Supervisor, Tariffs

ACCESS SERVICE

6 Switched Access Service (Cont'd)
6.4 Transmission Specifications (Cont'd)
6.4.2 Data Transmission Parameters

Two types of Data Transmission Parameters, i.e., Type DA and Type DB, are provided for the Feature Group arrangements. The specific applications in terms of the Feature Groups with which they are provided are set forth in 6.2.1(C), 6.2.2(C), 6.2.3(C) and 6.2.4(C) preceding. In addition, the WATS Switched Access Service is provided with Data Transmission Parameters. Following are descriptions of each.

(A) Data Transmission Parameters Type DA

(1) Signal to C-Notched Noise Ratio

The Signal to C-Notched Noise Ratio is equal to or greater than 33 dB.

Advice No. 03-28

Issued July 23, 2003

Effective August 23, 2003

Issued By CENTURYTEL OF WASHINGTON, INC. d/b/a CenturyTel
P.O. Box 9901, Vancouver, WA

(C)

By Pamela Donovan Title Supervisor, Tariffs

ACCESS SERVICE

6. Switched Access Service (Cont'd)
- 6.4 Transmission Specifications(Cont'd)
- 6.4.2 Data Transmission Parameters (Cont'd)
- (A) Data Transmission Parameters Type DA (Cont'd)
- (2) Envelope Delay Distortion
 The maximum Envelope Delay Distortion for the frequency bands and route miles specified is:
- | | |
|---|------------------|
| 604 to 2804 Hz | |
| less than 50 route miles | 500 microseconds |
| equal to or greater than 50 route miles | 900 microseconds |
| 1004 to 2404 Hz | |
| less than 50 route miles | 200 microseconds |
| equal to or greater than 50 route miles | 400 microseconds |
- (3) Impulse Noise Counts
 The Impulse Noise Counts exceeding a 65 dBmCO threshold in 15 minutes is no more than 15 counts.
- (4) Intermodulation Distortion
 The Second Order (R2) and Third Order (R3) Intermodulation Distortion products are equal to or greater than:
- | | |
|-------------------|-------|
| Second Order (R2) | 33 dB |
| Third Order (R3) | 37 dB |
- (5) Phase Jitter
 The Phase Jitter over the 4-300 Hz frequency band is less than or equal to 5° peak-to-peak.
- (6) Frequency Shift
 The maximum Frequency Shift does not exceed -2 to +2Hz.
- (B) Data Transmission Parameters Type DB
- (1) Signal to C-Notched Noise Ratio
 The signal to C-Notched Noise Ratio is equal to or greater than 30 dB.

Advice No. 03-28

Issued July 23, 2003

Effective August 23, 2003

Issued By CENTURYTEL OF WASHINGTON, INC. d/b/a CenturyTel

P.O. Box 9901, Vancouver, WA

By Pamela Donovan

Title Supervisor, Tariffs

(C)

ACCESS SERVICE

6. Switched Access Service (Cont'd)
- 6.4 Transmission Specifications (Cont'd)
- 6.4.2 Data Transmission Parameters (Cont'd)
- (B) Data Transmission Parameter Type DB (Cont'd)
- (2) Envelope Delay Distortion
 The maximum Envelope Delay Distortion for the frequency band and route miles specified is:
- | | |
|-----------------------------------|-----------------------|
| | <u>604 to 2804 Hz</u> |
| less than 50 route miles equal to | 800 microseconds |
| or greater than 50 route miles | 1000 microseconds |
-
- | | |
|-----------------------------------|------------------------|
| | <u>1004 to 2404 Hz</u> |
| less than 50 route miles equal to | 320 microseconds |
| or greater than 50 route miles | 500 microseconds |
- (3) Impulse Noise Counts
 The Impulse Noise Counts exceeding a 67 dB_{rnCO} threshold in 15 minutes is no more than 15 counts.
- (4) Intermodulation Distortion
 The Second Order (R2) and Third Order (R3) Intermodulation Distortion products are equal to or greater than:
- | | |
|-------------------|-------|
| Second Order (R2) | 31 dB |
| Third Order (R3) | 34 dB |
- (5) Phase Jitter
 The Phase Jitter over the 4-300 Hz frequency band is less than or equal to 7° peak-to-peak.
- (6) Frequency Shift
 The maximum Frequency Shift does not exceed -2 to +2 Hz.

Advice No. 03-28

Issued July 23, 2003

Effective August 23, 2003

Issued By CENTURYTEL OF WASHINGTON, INC. d/b/a CenturyTel
 P.O. Box 9901, Vancouver, WA

(C)

By Pamela Donovan Title Supervisor, Tariffs

ACCESS SERVICE

6. Switched Access Service (Cont'd)

6.5 Obligations of the Telephone Company

In addition to the obligations of the Telephone Company set forth in 2. preceding, the Telephone Company has certain other obligations pertaining only to the provision of Switched Access Service. These obligations are as follows:

6.5.1 Network Management

The Telephone Company will administer its network to insure the provision of acceptable service levels to all telecommunications users of the Telephone Company's network services. Generally, service levels are considered acceptable only when both end users and customers are able to establish connections with little or no delay encountered within the Telephone Company network. The Telephone Company maintains the right to apply protective controls, i.e., those actions, such as call gapping, which selectively cancel the completion of traffic, over any traffic carried over its network, including that associated with a customer's Switched Access Service. Generally, such protective measures would only be taken as a result of occurrences such as failure or overload of Telephone Company or customer facilities, natural disasters, mass calling or focused overloads, or national security demands. In the event that the protective controls applied by the Telephone Company result in the complete loss of service by the customer, the customer will be granted a Credit Allowance for Service Interruption.

6.5.2 Design and Traffic Routing of Switched Access Service

For Feature Groups C and D, the Telephone Company shall design and determine the routing of Switched Access Service, including the selection of the first point of switching and the selection of facilities from the interface to any switching point and to the end offices where busy hour minutes of capacity are ordered. The Telephone Company shall also decide if capacity is to be provided by originating only, terminating only, or two-way trunk groups. Finally, the Telephone Company will decide whether trunk side access will be provided through the use of two-wire or four-wire trunk terminating equipment. Selection of facilities and equipment and traffic routing of the service are based on standard engineering methods, available facilities and equipment, and the Telephone Company traffic routing plans. If the customer desires routing or directionality different from that determined by the Telephone

Advice No. 03-28

Issued July 23, 2003

Effective August 23, 2003

Issued By CENTURYTEL OF WASHINGTON, INC. d/b/a CenturyTel
P.O. Box 9901, Vancouver, WA

(C)

By Pamela Donovan Title Supervisor, Tariffs

ACCESS SERVICE

6. Switched Access Service (Cont'd)
6.5 Obligations of the Telephone Company (Cont'd)
6.5.2 Design and Traffic Routing of Switched Access Service (Cont'd)

Company, the Telephone Company will work cooperatively with the customer in determining (1) whether the service is to be directly to an end office or through an access tandem switch and (2) the directionality of the service.

For Feature Groups A and B, the line or trunk directionality and traffic routing of the Switched Access Service between the customer's premises and the entry switch are determined by the customer's order for service. Additionally, for Feature Group B the customer may order the optional feature Customer Specification of Local Transport Termination.

6.5.3 Provision of Service Performance Data

Subject to availability, end-to-end service performance data available to the Telephone Company through its own service evaluation routines, may also be made available to the customer based on previously arranged intervals and format. These data provide information on overall end-to-end call completion and non completion performance, e.g., customer equipment blockage, failure results and transmission performance. These data do not include service performance data which are provided under other tariff sections, e.g., testing service results. If data are to be provided in other than paper format, the charges for such exchange will be determined on an individual case basis.

Advice No. 03-28

Issued July 23, 2003

Effective August 23, 2003

Issued By CENTURYTEL OF WASHINGTON, INC. d/b/a CenturyTel
P.O. Box 9901, Vancouver, WA

(C)

By Pamela Donovan Title Supervisor, Tariffs

ACCESS SERVICE

6. Switched Access Service (Cont'd)

6.5 Obligations of the Telephone Company (Cont'd)

6.5.4 Trunk Group Measurement Reports

Subject to availability, the Telephone Company will make available trunk group data in the form of usage in CCS, peg count and overflow, to the customer based on previously agreed to intervals.

6.5.5 Determination of Number of Transmission Paths

For Feature Groups A and B, which are ordered on a per line or per trunk basis respectively, the customer specifies the number of transmission paths in the order for service. The Telephone Company will determine the number of Switched Access Service transmission paths to be provided for the Switched Access Feature Group C or D busy hour minutes of capacity ordered. A transmission path is a communication path within the frequency bandwidth of approximately 300 to 3000 Hz or a derived communication path of a frequency bandwidth of approximately 300 Hz to 300 Hz provided over a high frequency analog facility or a high speed digital facility between a customer, end user or Telephone Company location and another customer, end user or Telephone Company location. The number of transmission paths will be developed using the total busy hour minutes of capacity by traffic type (as described in 6.1.1(E) preceding) for the end offices for each Feature Group ordered from a customer's premises. The total busy hour minutes of capacity by type for the Feature Group end office will be converted to transmission paths using standard Telephone Company traffic engineering methods. The number of transmission paths provided shall be the number required based on (1) the use of access tandem switches and end office switches, (2) the use of end office switches only, or (3) the use of tandem switches only.

6.5.6 Determination of Number of End Office Transport Terminations

For analog entry switches, a termination will be provided for each transmission path provided. For digital entry switches, an equivalent termination will be provided for each transmission path provided.

6.5.7 Design Blocking Probability

The Telephone Company will design the facilities used in the provision of Switched Access Service to meet the blocking probability criteria as set forth in (A) through (D) following.

Advice No. 03-28

Issued July 23, 2003

Effective August 23, 2003

Issued By CENTURYTEL OF WASHINGTON, INC. d/b/a CenturyTel
P.O. Box 9901, Vancouver, WA

(C)

By Pamela Donovan Title Supervisor, Tariffs

ACCESS SERVICE

- 6. Switched Access Service (Cont'd)
- 6.5 Obligations of the Telephone Company (Cont'd)
- 6.5.7 Design Blocking Probability (Cont'd)
 - (D) (Cont'd)
 - (1) (Cont'd)

Number of Transmission Paths p.m. <u>Per Trunk Group</u>	Measured Blocking Thresholds in the Time Consistent Busy Hour for the Number of Measurements Taken between 8:00 a.m. and 11:00			
	<u>Per Trunk Group</u>			
	15-20	11-14	7-10	3-6
	<u>Measurements</u>		<u>Measurements</u>	
2	.070	.080	.090	140
3	.050	.060	.070	.090
4	.050	.060	.070	.080
5-6	.040	.050	.060	.070
7 or More	.030	.035	.040	.060

- (2) For transmission paths carrying first routed traffic between an end office and a premises via an access tandem, the measured blocking thresholds are as follows:

Number of Transmission Paths p.m. <u>Per Trunk Group</u>	Measured Blocking Thresholds in the Time Consistent Busy Hour for the Number of Measurements Taken between 8:00 a.m. and 11:00			
	<u>Per Trunk Group</u>			
	15-20	11-14	7-10	3-6
	<u>Measurements</u>		<u>Measurements</u>	
2	.045	.055	.060	.095
3	.035	.040	.045	.060
4	.035	.040	.045	.055
5-6	.025	.035	.040	.045
7 or More	.020	.025	.030	.040

Advice No. 03-28

Issued July 23, 2003

Effective August 23, 2003

Issued By CENTURYTEL OF WASHINGTON, INC. d/b/a CenturyTel
 P.O. Box 9901, Vancouver, WA

(C)

By Pamela Donovan Title Supervisor, Tariffs

ACCESS SERVICE

6. Switched Access Service (Cont'd)
6.6 Obligations of the Customer

In addition to the obligations of the customer set forth in 2. preceding the customer has certain specific obligations pertaining to the use of Switched Access Service. These obligations are as follows:

6.6.1 Report Requirements

Customers are responsible for providing the following reports to the Telephone Company, when applicable.

(A) Jurisdictional Reports

When a customer orders Switched Access Service for both interstate and intrastate use, the customer is responsible for providing reports as set forth in 2.3.14 preceding. Charges will be apportioned in accordance with those reports. The method to be used for determining the intrastate charges is set forth in 2.3.15 preceding.

(B) Code Screening Reports

When a customer orders service class routing, trunk access limitation or call gapping arrangements, it must report the number of trunks and/or the appropriate codes to be instituted in each end office or access tandem switch, for each of the arrangements ordered.

Advice No. 03-28

Issued July 23, 2003

Effective August 23, 2003

Issued By CENTURYTEL OF WASHINGTON, INC. d/b/a CenturyTel
P.O. Box 9901, Vancouver, WA

(C)

By Pamela Donovan Title Supervisor, Tariffs

ACCESS SERVICE

6. Switched Access Service (Cont'd)

6.7 Rate Regulations

This section contain the specific regulations governing the rates and charges that apply for Switched Access Service.

6.7.1 Description and Application of Rates and Charges

There are three types of rates and charges that apply to Switched Access Service. These are monthly recurring rates, usage rates and nonrecurring charges. These rates and charges are applied differently to the various rate elements as set forth in (D) following.

(A) Monthly Rates

Monthly rates are flat recurring rates that apply each month or fraction thereof that a specific rate element is provided. For billing purposes, each month is considered to have 30 days.

(B) Usage Rates

Usage rates are rates that apply only when a specific rate element is used. These are applied on a per access minute basis. Access minute charges are accumulated over a monthly period.

(C) Nonrecurring Charges

Nonrecurring charges are one-time charges that apply for a specific work activity (installation or change to an existing service - administrative non facility related changes do not have nonrecurring charges). The types of nonrecurring charges that apply for Switched Access Service are: installation of service and service rearrangements.

(1) Installation of Service

Nonrecurring charges apply to each Switched Access Service installed. For FGA and FGB, which are ordered on a per line or trunk basis respectively, the charge is applied per line on trunk. For FGC and FGD, which are ordered on a busy hour minutes of capacity basis, the charge is also applied on a per trunk basis but the charge applies only when the capacity ordered requires the installation of an additional trunk(s).

Advice No. 03-28

Issued July 23, 2003

Effective August 23, 2003

Issued By CENTURYTEL OF WASHINGTON, INC. d/b/a CenturyTel
P.O. Box 9901, Vancouver, WA

(C)

By Pamela Donovan

Title Supervisor, Tariffs

ACCESS SERVICE

6. Switched Access Service (Cont'd)
 6.7 Rate Regulations (Cont'd)
 6.7.1 Types of Rates and Charges (Cont'd)
 (C) Nonrecurring Charge (Cont'd)
 (2) Service Rearrangements

All changes to existing services will be treated as a discontinuance of the existing service and an installation of a new service. The nonrecurring charge described in (1) preceding will apply for this work activity. Moves that change the physical location of the points of termination are described and charged for as set forth in the following.

Administrative changes will be made without charge(s) to the customer. Administrative changes are as follows:

- Change of customer name,
- Change of customer or customer's end user premises address when the change of address is not a result of a physical relocation of equipment
- Change in billing date (name, address, or contact name or telephone number),
- Change of agency authorization,
- Change of customer circuit identification,
- Change of billing account number,
- Change of customer test line number,
- Change of customer or customer's end user contact name of telephone number,
- Change of implementation contact name or telephone number, or
- Change of design contact name or telephone number.
- Change of jurisdiction

Advice No. 03-28

Issued July 23, 2003

Effective August 23, 2003

Issued By CENTURYTEL OF WASHINGTON, INC. d/b/a CenturyTel
 P.O. Box 9901, Vancouver, WA

(C)

By Pamela Donovan Title Supervisor, Tariffs

ACCESS SERVICE

6. Switched Access Service (Cont'd)

6.7 Rate Regulations (Cont'd)

6.7.1 Types of Rates and Charges (Cont'd)

(D) Application of Rates (Cont'd)

(4)

- (a) All access minutes that originate from or terminate at the equal access end office(s) will be billed at premium rates. Access minutes that originate from or terminate at end offices not equipped with equal access capabilities, hereinafter referred to as nonpremium access minutes, will continue to be billed at transitional rates. Transitional usage or monthly rates will apply as follows depending on the type of service.
 - (i) Premium access minutes will be determined as set forth in (b) following.
- (b) The number of access minutes to be rated as premium access minutes is determined as follows:
 - (i) Where end office specific usage data is available, premium rates apply to the measured access minutes originating from or terminating at the equal access end office(s).

Advice No. 03-28

Issued July 23, 2003

Effective August 23, 2003

Issued By CENTURYTEL OF WASHINGTON, INC. d/b/a CenturyTel
P.O. Box 9901, Vancouver, WA

(C)

By Pamela Donovan

Title Supervisor, Tariffs

ACCESS SERVICE

6. Switched Access Service (Cont'd)
- 6.7 Rate Regulations (Cont'd)
- 6.7.1 Types of Rates and Charges (Cont'd)
- (D) Application of Rates (Cont'd)
- (4) (Cont'd)
- (b) (Cont'd)
- (ii) Where end office specific usage data is not available for originating and/or terminating FGA, the total originating usage will be measured or assumed usage at the entry switch as set forth in 6.7.1(D)(4)(c) and 3.7(C). FGA originating and/or terminating usage will then be apportioned between premium and non-premium access minutes in the following manner. First, develop the ratio of the number of subscriber lines in the local calling area of the entry switch that are served by equal access end offices to the total number of subscriber lines in that local calling area. Then apply this ratio to the total number of originating and/or terminating FGA access minutes to determine the usage to be billed at premium rates, unless adjusted as set forth in (v) following. The local calling area of the entry switch is as defined in the Telephone Company's local and/or general exchange service tariff. For purposes of administering this regulation, subscriber lines are defined as exchange service lines provided by the Telephone Company under its local and/or general exchange service tariff.
- (iii)
- (iv) Where end office specific usage data is not available for originating and/or terminating FGB, the total originating and/or terminating usage will be measured or assumed usage at the entry switch (i.e., access tandem) as set forth in 6.7.8 following. FGB originating and/or terminating usage will then be apportioned between premium and non-premium access minutes in the following manner. First, develop the ratio of the number of subscriber lines provided to end offices subtending the access tandem that are served by equal access end offices to

Advice No. 03-28

Issued July 23, 2003

Effective August 23, 2003

Issued By CENTURYTEL OF WASHINGTON, INC. d/b/a CenturyTel
 P.O. Box 9901, Vancouver, WA

(C)

By Pamela Donovan Title Supervisor, Tariffs

ACCESS SERVICE

6. Switched Access Service (Cont'd)
 6.7 Rate Regulations (Cont'd)
 6.7.1 Types of Rates and Charges (Cont'd)
 (D) Application of Rates (Cont'd)
 (4) (Cont'd)
 (b) (Cont'd)
 (iv) (Cont'd)

the total number of subscriber lines in all end offices subtending the access tandem. Then apply this ratio to the total number of originating and/or terminating FGB access minutes to determine the usage to be billed at premium rates, unless adjusted as set forth in (v) following. For purposes of administering this regulation, subscriber lines are defined as exchange service lines provided by the Telephone Company under its local and/or general exchange service tariff.

The ratio used to calculate the premium usage as set forth in (ii) and (iv) preceding will be determined on a quarterly basis and provided to the customer with the last bill rendered for the preceding quarter of mailed separately within five working days after the first day of the new quarter. A quarter is defined for these purposes as beginning on the first day of January, April, July or October.

- (v) Where FGD Switched Access Service is provided to a customer in an end office(s) where that customer's premium access minutes have been determined in accordance with (ii) and (iv) preceding, such premium access minutes will be adjusted in the following manner. For each FGD access minute originating and/or terminating from that end office, the premium access minutes as set forth in (ii) and (iv) preceding will be reduced on a one-for-one basis, but in no event shall the reduction exceed the total number of premium access minutes as set forth in (ii) and (iv) from that end office. The customer will be billed for the revised number of premium access minutes.

Advice No. 03-28

Issued July 23, 2003

Effective August 23, 2003

Issued By CENTURYTEL OF WASHINGTON, INC. d/b/a CenturyTel
 P.O. Box 9901, Vancouver, WA

(C)

By Pamela Donovan

Title Supervisor, Tariffs

ACCESS SERVICE

6. Switched Access Service (Cont'd)
6.7 Rate Regulations (Cont'd)
6.7.1 Types of Rates and Charges (Cont'd)
(D) Application of Rates (Cont'd)

The Telephone Company will provide written notification to all access customers of record within a particular LATA that an end office in that LATA is scheduled to be converted to an equal access end office. This notification will be sent, via certified U.S. Mail, to each customer of record in the LATA where the conversion is scheduled to occur, at least six months in advance of the conversion date.

The customer will have the choice of converting existing services to equal access (i.e., Feature Group D) at no charge or retaining the existing services (with the exception of FGC). Premium rates will apply to the total access minutes beginning on the actual conversion date, whether the customer chooses to convert to FGD or retain existing services.

- (E) 800 Access Service Data Base Query

In addition to the rates and charges described preceding which are applicable to all Switched Access Services, the 800 Access Service Data Base Query charge applies for each 800 call that is completed to the customer. The Basic Query charge applies for queries which do not have vertical services associated. The Enhanced Query charge applies to all queries which contain vertical services.

- 6.7.2 Minimum Periods

Switched Access Service is provided for a minimum period of one month.

6.7.3

6.7.4

6.7.5

Advice No. 03-28

Issued July 23, 2003

Effective August 23, 2003

Issued By CENTURYTEL OF WASHINGTON, INC. d/b/a CenturyTel
P.O. Box 9901, Vancouver, WA

(C)

By Pamela Donovan Title Supervisor, Tariffs

ACCESS SERVICE

6. Switched Access Service (Cont'd)

6.7 Rate Regulations (Cont'd)

6.7.8 Measuring Access Minutes (Cont'd)

(A) Feature Group Assumed Usage (Cont'd)

- (2) When a Feature Group B Switched Access Service is arranged for two-way calling and is provided where neither the originating access minutes nor the terminating access minutes are measured, the assumed intrastate access minutes of use are 9000 minutes. When originating only FGB Switched Access Service is provided where the originating access minutes are not measured, the originating assumed intrastate access minutes are 4500 minutes. When terminating only FGB Switched Access Service is provided, where the terminating access minutes are not measured, the terminating assumed intrastate access minutes are 4500. Where measurement capability exists for either originating or terminating usage, but not both, on a trunk arranged for two-way calling, the number of access minutes per trunk will be an assumed 9000 or the measured usage, whichever is greater. If the usage in the measured direction exceeds 9000 access minutes, it will be assumed that there is zero usage in the unmeasured direction. If the measured usage is less than 9000 access minutes, the usage in the unmeasured direction will be assumed to be 9000 access minutes minus the measured (e.g., 9000-6000 measured =3000 assumed in unmeasured direction).

(B) Feature Group A Usage Measurement

For Originating calls over FGA, usage measurement begins when the originating FGA entry switch receives an off-hook supervisory signal forwarded from the customer's point of termination. (Where FGA is used for MTS/WATS-type services, this off-hook signal is generally provided by the customer's equipment. Where FGA is used for FX/ONAL services, the off-hook signal is generally forwarded by the customer's equipment when the called party answers.)

The measurement of originating call usage over FGA ends when the originating FGA entry switch receives an on-hook supervisory signal from either the originating end user's end office, indicating the originating end user has disconnected, or the customer's point of termination, whichever is recognized first by the entry switch.

Advice No. 03-28

Issued July 23, 2003

Effective August 23, 2003

Issued By CENTURYTEL OF WASHINGTON, INC. d/b/a CenturyTel
 P.O. Box 9901, Vancouver, WA

(C)

By Pamela Donovan

Title Supervisor, Tariffs

ACCESS SERVICE

6. Switched Access Service (Cont'd)
6.7 Rate Regulations (Cont'd)
6.7.8 Measuring Access Minutes (Cont'd)

(D) Feature Group C Usage Measurement

For originating calls over FGC, usage measurement begins when the originating FGC entry switch receives answer supervision from the customer's point of termination, indicating the called party has answered.

The measurement of originating call usage over FGC ends when the originating FGC entry switch receives disconnect supervision from either the originating end user's end office, indicating the originating end user has disconnected, or the customer's point of termination, whichever is recognized first by the entry switch.

For terminating calls over FGC to services other than 800, 900 or Directory Assistance, terminating FGC usage is not directly measured at the terminating entry switch, but is imputed from originating usage, excluding usage from calls to 800, 900 or Directory Assistance Services.

For terminating calls over FGC or 800 Service, usage measurement begins when the terminating FGC entry switch receives answer supervision from the terminating end user's end office, indicating the terminating 800 Service end user has answered.

The measurement of terminating call usage over FGC to 800 Service ends when the terminating FGC entry switch receives an on-hook supervisory signal from the terminating end user's end office, indicating the terminating 800 Service end user has disconnected, or from the customer's point of termination, whichever is recognized first by the entry switch.

Advice No. 03-28

Issued July 23, 2003

Effective August 23, 2003

Issued By CENTURYTEL OF WASHINGTON, INC. d/b/a CenturyTel
P.O. Box 9901, Vancouver, WA

(C)

By Pamela Donovan Title Supervisor, Tariffs

ACCESS SERVICE

6. Switched Access Service (Cont'd)
6.7 Rate Regulations (Cont'd)
6.7.8 Measuring Access Minutes (Cont'd)

(E) Feature Group D Usage Measurement

For originating calls over FGD, usage measurement begins when the originating FGD entry switch receives the first wink supervisory signal forwarded from the customer's point of termination.

The measurement of originating call usage over FGD ends when the originating FGD entry switch receives disconnect supervision from either the originating end user's end office, indicating the originating end user has disconnected, or the customer's point of termination, whichever is recognized first by the entry switch.

For terminating calls over FGD, the measurement of access minutes begins when the terminating FGD entry switch receives answer supervision from the terminating end user's end office, indicating the terminating end user has answered.

The measurement of terminating call usage over FGD ends when the terminating FGD entry switch receives disconnect supervision from either the terminating end user's end office, indicating the terminating end user has disconnected, or the customer's point of termination, whichever is recognized first by the entry switch.

Advice No. 03-28

Issued July 23, 2003

Effective August 23, 2003

Issued By CENTURYTEL OF WASHINGTON, INC. d/b/a CenturyTel
P.O. Box 9901, Vancouver, WA

(C)

By Pamela Donovan Title Supervisor, Tariffs

ACCESS SERVICE

6. Switched Access Service (Cont'd)
6.7 Rate Regulations (Cont'd)
6.7.10 Application of Rates for Extension Service

Feature Group A Switched Access Service and Feature Group C and D WATS Access Lines are available¹ with extensions, i.e., additional terminations of the service at different building(s) in the same or a different LATA. Feature Group A extensions within the LATA are provided and charged for under the Telephone Company's local and/or general exchange service tariffs. Feature Group A extensions in different LATAs and WATS Access Line extensions are provided and charged for as Special Access Service. The rate elements which apply are: A Voice Grade Connecting Channel, Channel Mileage, if applicable, and a Channel Interface (with signaling). All appropriate monthly rates and nonrecurring charges will apply.

6.7.11 Message Unit Credit

Calls from end users to the seven digit local telephone numbers associated with Feature Group A Switched Access Service are subject to Telephone Company local and/or general exchange service tariff charges (including message unit and toll charges as applicable). The monthly bills rendered to customers for their Feature Group A Switched Access Service will include a credit to reflect any message unit charges collected from their end users under the Telephone Company's local and/or general exchange service tariffs. No credit will apply for any terminating FGA access minutes. The message unit credit for originating access minutes will be based on the generally applicable message unit charge of the Telephone Company.

6.7.12 Local Information Delivery Services

Calls over Switched Access in the terminating direction to certain community information services will be rated under the applicable rates for Switched Access Service as set forth in 6.8 following. In addition, the charges per call as specified under the Telephone Company's local and/or general exchange service tariffs, e.g., 976 (DIAL-IT) Network Services, will also apply.

Advice No. 03-28

Issued July 23, 2003

Effective August 23, 2003

Issued By CENTURYTEL OF WASHINGTON, INC. d/b/a CenturyTel
P.O. Box 9901, Vancouver, WA

(C)

By Pamela Donovan Title Supervisor, Tariffs

WN U-4

Fifth Revised Sheet No. 174
Cancels
Fourth Revised Sheet No. 174
CENTURYTEL OF WASHINGTON, INC.

(C)

ACCESS SERVICE

6. Switched Access Service (Cont'd)

Advice No. 03-28

Issued July 23, 2003 Effective August 23, 2003
Issued By CENTURYTEL OF WASHINGTON, INC. d/b/a CenturyTel
 P.O. Box 9901, Vancouver, WA
By Pamela Donovan Title Supervisor, Tariffs

(C)

ACCESS SERVICE

6. Switched Access Service (Cont'd)6.8 Nonchargeable Optional Features6.8.2 Local Transport

(1) <u>Supervisory Signaling</u>	<u>FID</u>
DX Supervisory Signaling arrangement Per Transmission Path*	NCI ++DX+
SF Supervisory Signaling arrangement Per Transmission Path**	NCI ++SF+
E&M Type I Supervisory Signaling arrangement Per Transmission Path*	NCI ++EA+
E&M Type II Supervisory Signaling arrangement Per Transmission Path*	NCI ++EB+
E&M Type III Supervisory Signaling Per Transmission Paths*	NCI ++EC+
Tandem Supervisory Signaling Per Transmission Path**	NCI ++EX+
(2) Customer specification of the receive transmission level at the first point of switching within a range acceptable to the Telephone Company Per Transmission Path***	TLV
(3) Customer specification of Local Transport Termination Four-wire termination in line of two-wire termination Per Transmission Path****	LT1++

* Available with Interface Group 2 for FGC and FGD.

** Available with Interface Group 2 for FGA.

*** Available with Interface Groups 2, 3 and 6 for FGA and FGB. The range of transmission levels which may be specified is described in Technical Reference PUB 62500.

**** Available with Feature Group B with Type B Transmission Performance.

Advice No. 03-28

Issued July 23, 2003

Effective August 23, 2003

Issued By CENTURYTEL OF WASHINGTON, INC. d/b/a CenturyTel
 P.O. Box 9901, Vancouver, WA

(C)

By Pamela Donovan Title Supervisor, Tariffs

WN U-4

Fifth Revised Sheet No. 176
Cancels
Fourth Revised Sheet No. 176
CENTURYTEL OF WASHINGTON, INC.

(C)

ACCESS SERVICE

6. Switched Access Service (Cont'd)
6.8 Nonchargeable Optional Features (Cont'd)

Advice No. 03-28

Issued July 23, 2003 Effective August 23, 2003
Issued By CENTURYTEL OF WASHINGTON, INC. d/b/a CenturyTel
 P.O. Box 9901, Vancouver, WA
By Pamela Donovan Title Supervisor, Tariffs

(C)

ACCESS SERVICE

6. Switched Access Service (Cont'd)
- 6.8 Nonchargeable Optional Features (Cont'd)
- 6.8.3 End Office (Cont'd)
- (A) Local Switching (Cont'd)
- (1) Common Switching Nonchargeable Optional Features (Cont'd)
- | | |
|---|------------|
| | <u>FID</u> |
| Automatic Number Identification
(available with FGB, FGC and FGD)
- Per End Office | ANI |
| Up to 7 Digit Outpulsing of Access Digits to IC
(available with FGB)
- Per Entry Switch | USDO |
| Delay Dial Start-Pulsing Signaling
(available with FGC)
- Per Transmission Path Group | DDSP |
| Immediate Dial Pulse Address Signaling
(available with FGC)
- Per Transmission Path Group | ADS IDP |
| Dial Pulse Address Signaling
(available with FGC)
-Per Transmission Path Group | ADS DP |

Advice No. 03-28

Issued July 23, 2003

Effective August 23, 2003

Issued By CENTURYTEL OF WASHINGTON, INC. d/b/a CenturyTel
 P.O. Box 9901, Vancouver, WA

(C)

By Pamela Donovan Title Supervisor, Tariffs

ACCESS SERVICE

6. Switched Access Service (Cont'd)6.8 Nonchargeable Optional Features (Cont'd)6.8.3 End Office (Cont'd)(A) Local Switching (Cont'd)(1) Common Switching Nonchargeable Optional Features (Cont'd)

	<u>FID</u>
Service Class Routing (available with FGC and FGD) - Per Transmission Path Group	SCRT
Alternate Traffic Routing (available with FGC and FGD) - Per Transmission Path Group	ARTG
Trunk Access Limitation Arrangement (available with FGC and FGD) - Per End Office	CHOK
Call Gapping Arrangement (available with FGD) - Per End Office	CGAP
Band Advance Arrangement for use with Special Access Dedicated Access Lines (available with FGC and FGD) - Per Arrangement	BAAD

Advice No. 03-28

Issued July 23, 2003

Effective August 23, 2003

Issued By CENTURYTEL OF WASHINGTON, INC. d/b/a CenturyTel
 P.O. Box 9901, Vancouver, WA

(C)

By Pamela Donovan Title Supervisor, Tariffs

ACCESS SERVICE

6. Switched Access Service (Cont'd)6.8 Nonchargeable Optional Features (Cont'd)6.8.3 End Office (Cont'd)(A) Local Switching (Cont'd)(2) Transport Termination Nonchargeable OptionsFID

(a) Line Side Terminations (For FGA)

Two Way Operation

- Dial Pulse with Loop Start

NC +++A

- Dial Pulse with Ground Start

NC +++E

- DTMF with Loop Start

NC +++F

- DTMF with Ground Start

NC +++G

Terminating Operation

- Dial Pulse with Loop Start

NC +++N

- Dial Pulse with Ground Start

NC +++P

- DTMF with Loop Start

NC +++R

- DTMF with Ground Start

NC +++S

Originating Operation

- Loop Start

NC +++U

- Ground Start

NC +++V

(b) Trunk Side Terminations (For FGB, FGC, and FGD)

Standard Trunk for Originating,
 Terminating or Two-Way operation
 (available with FGB,
 FGC and FGD)

TTC SO

TTC ST

TTC TY

Rotary Dial Station Signaling Trunk
 (available with FGB)

TTC RD

Operator Trunk, Coin Non-Coin or
 Combined Coin and Non-Coin(available with FGC)

TTC CO

Operator Trunk, Full Feature Arrangement
 (available with FGD)

TTC FF

Advice No. 03-28

Issued July 23, 2003

Effective August 23, 2003

Issued By CENTURYTEL OF WASHINGTON, INC. d/b/a CenturyTel
 P.O. Box 9901, Vancouver, WA

(C)

By Pamela Donovan

Title Supervisor, Tariffs

ACCESS SERVICE

6. Switched Access Service (Cont'd)
 6.8 Nonchargeable Optional Features (Cont'd)
 6.8.3 End Office (Cont'd)

(B) Line Terminations

FID

(1) Access Line Termination Nonchargeable Options

(a) Line Side Terminations:

Originating Only Loop Start, Line Side
 Connection, with DTMF Address Signaling
 - Per Transmission Path NC ++R

Originating Only Loop Start, Line Side
 Connection, with Dial Pulse Address Signaling
 - Per Transmission Path NC +++N

Originating Only Ground Start, Line Side
 Connection, with DTMF Address Signaling
 - Per Transmission Path NC +++S

Originating Only Ground Start, Line Side
 Connection, with Dial Pulse Address Signaling
 - Per Transmission Path NC +++P

Advice No. 03-28

Issued July 23, 2003

Effective August 23, 2003

Issued By CENTURYTEL OF WASHINGTON, INC. d/b/a CenturyTel
 P.O. Box 9901, Vancouver, WA

(C)

By Pamela Donovan Title Supervisor, Tariffs

ACCESS SERVICE

6. Switched Access Service (Cont'd)

6.8 Nonchargeable Optional Features (Cont'd)

6.8.3 End Office (Cont'd)

(B) Line Terminations (Cont'd)

(1) Access Line Termination Nonchargeable Options

(a) Line Side Terminations: (Cont'd)

FID

Terminating Only Loop Start, Line Side Connection
 - Per Transmission Path

NC +++U

Terminating Only Ground Start, Line Side Connection
 - Per Transmission Path

NC +++V

(b) Trunk Side Terminations:

Terminating Only Trunk Side Connection for forwarding
 of Dialed Number Identification to End User
 - Per Transmission Path

NC +++T

6.8.4 Local Business Line Rates for Resold Service

The local business line rates that apply for arrangements provided as set forth in 6.7.3 preceding are contained in the general and/or local exchange service tariffs of the Telephone Company.

Advice No. 03-28

Issued July 23, 2003

Effective August 23, 2003

Issued By CENTURYTEL OF WASHINGTON, INC. d/b/a CenturyTel
 P.O. Box 9901, Vancouver, WA

(C)

By Pamela Donovan

Title Supervisor, Tariffs

WN U-4

Fourth Revised Sheet No. 184
Cancels
Third Revised Sheet No. 184
CENTURYTEL OF WASHINGTON, INC.

(C)

ACCESS SERVICE

6. Switched Access Service (Cont'd)
6.8 Nonchargeable Optional Features (Cont'd)

Advice No. 03-28

Issued July 23, 2003 Effective August 23, 2003
Issued By CENTURYTEL OF WASHINGTON, INC. d/b/a CenturyTel
 P.O. Box 9901, Vancouver, WA
By Pamela Donovan Title Supervisor, Tariffs

(C)

ACCESS SERVICE

7. Special Access Service

7.1 General

Special Access Service provides a transmission path to connect customer designated premises *, either directly or through a Telephone Company hub where bridging or multiplexing functions are performed. Special Access Service includes all exchange access not utilizing Telephone Company end office switches.

The connections provided by Special Access Service can be either analog or digital. Analog connections are differentiated by spectrum and bandwidth. Digital connections are differentiated by bit rate. The specific types of services (e.g., Narrowband, Voice Grade, Digital, High Capacity) provided under Special Access Service are described in 7.2 following.

7.1.1 Rate Categories

There are four basic rate categories which apply to Special Access Service:

- Optional Miscellaneous Functions
- Special Transport
- Features and Functions (Optional)
- Special Access Line (Local Channel)

* Telephone Company Centrex CO-like switches are considered to be customer designated premises for purposes of this tariff.

Advice No. 03-28

Issued July 23, 2003

Effective August 23, 2003

Issued By CENTURYTEL OF WASHINGTON, INC. d/b/a CenturyTel
P.O. Box 9901, Vancouver, WA

(C)

By Pamela Donovan Title Supervisor, Tariffs

ACCESS SERVICE

- 7. Special Access Service (Cont'd)
- 7.1 General (Cont'd)
- 7.1.1 Rate Categories (Cont'd)

The following diagram depicts a generic view of the components of Special Access Service and the manner in which the components are combined to provide a complete Access Service.

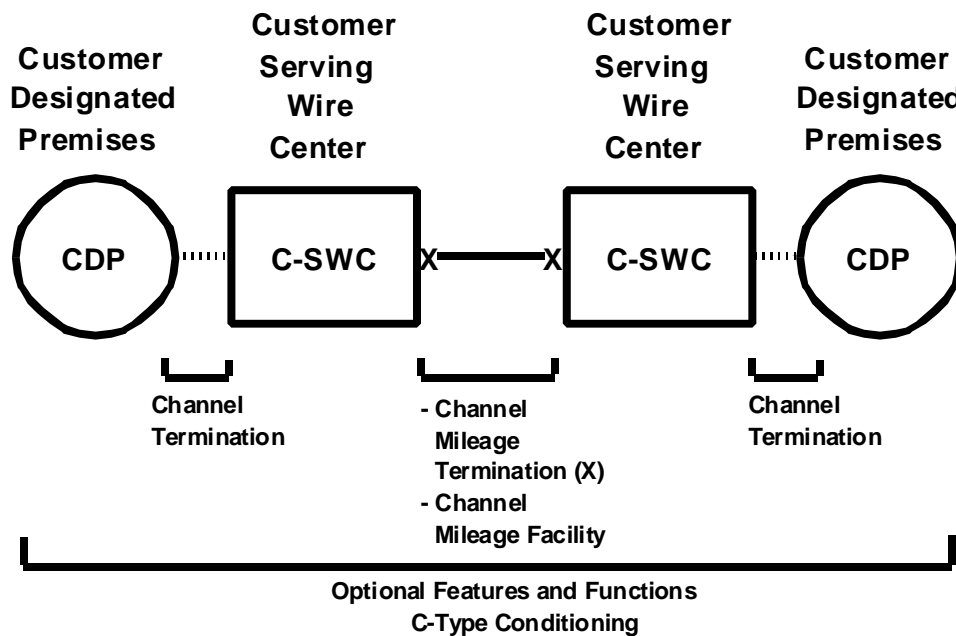

(C)

(C)

Advice No. 03-28

Issued July 23, 2003

Effective August 23, 2003

Issued By CENTURYTEL OF WASHINGTON, INC. d/b/a CenturyTel
 P.O. Box 9901, Vancouver, WA

By Pamela Donovan Title Supervisor, Tariffs

(C)

ACCESS SERVICE

7. Special Access Service (Cont'd)

7.1 General (Cont'd)

7.1.1 Rate Categories (Cont'd)

(A) Optional Miscellaneous Functions

The rate category applies to equipment used to condition a basic voice grade channel, for multiplexing, for gain conditioning, bridging and improved return loss.

(B) Special Transport (Interexchange Channel)

This rate category applies to the interexchange channel between the serving wire centers associated with two customer designated premises, between a serving wire center associated with a customer designated premises and a Telephone Company hub or between two Telephone Company hubs or to a point of interface with another exchange telephone company.

(C) Features and Functions (optional)

This rate category provides optional available facility interface combinations (including signaling), and optional features or functions that improve the quality or utility of a service to meet specific communications requirements.

(D) Special Access Line (Local Channel)

This rate category provides for the communications path between a customer designated premises and the serving wire center of that premises. This rate category also provides the actual physical transmission facilities between and end user serving wire center and a WATS serving office (for Dedicated Access Line Service Only). The facilities may be either analog or digital. When customers elect to provide the inside wiring at customer designated premises for connection to the Special Access Line, a reduced charge as set forth in 7.5.4(B) applies. For purposes of this tariff, inside wiring is delineated pursuant to Part 68 of the Commission's Rules.

Advice No. 03-28

Issued July 23, 2003

Effective August 23, 2003

Issued By CENTURYTEL OF WASHINGTON, INC. d/b/a CenturyTel

P.O. Box 9901, Vancouver, WA

(C)

By Pamela Donovan

Title Supervisor, Tariffs

ACCESS SERVICE

7. Special Access Service (Cont'd)

7.1 General (Cont'd)

7.1.2 Facility Interface (FI) Combinations

When ordering Special Access Service, the customer must specify the facility interface (FI) that is desired for the service ordered. The FI defines the technical characteristics associated with the type of signaling and type of facilities presented for connection to the Access Service at each customer location.

The FIs specified for the premises may be asymmetrical or symmetrical. However, only certain combinations are technically possible. Therefore, for purposes of this tariff, FIs are being described in terms of available combinations for all services except Dedicated Access Line Service which is only provided between an end user premises and a WATS serving office. These combinations are set forth in 7.2 following.

7.1.3 Optional Miscellaneous Functions

Optional miscellaneous functions may be added at the customer's option to a service to improve its quality or utility to meet specific communications requirements. These are not necessarily identifiable with specific facilities, but rather represent the end result in terms of performance characteristics which may be obtained. These characteristics may be obtained by using various combinations of facilities. Although the facilities necessary to perform a specified function may be installed at various locations along the path of the service, including the customer designated premises, they will be charged for as additional rate elements.

Examples of optional miscellaneous functions that are available include, but are not limited to, the following:

Conditioning
Bridging

Descriptions for each of the available optional miscellaneous functions are set forth in 7.5.3(C) and (D) following.

7.1.4 Service Configurations

There are two types of service configurations over which Special Access Services are provided: two-point service and multipoint service.

Advice No. 03-28

Issued July 23, 2003

Effective August 23, 2003

Issued By CENTURYTEL OF WASHINGTON, INC. d/b/a CenturyTel
P.O. Box 9901, Vancouver, WA

(C)

By Pamela Donovan Title Supervisor, Tariffs

ACCESS SERVICE

7. Special Access Service (Cont'd)
7.1 General (Cont'd)
7.1.4 Service Configurations (Cont'd)
(A) Two-Point-Service

A two-point service connects two customer designated premises, either on a directly connected basis or through a Telephone Company hub where multiplexing functions are performed. These hub locations are found in Section 15.

Applicable rate elements are:

Special Access Line
Special Transport (as applicable)
Features & Functions
Optional Miscellaneous Functions (when applicable)

In addition, the Special Access Surcharge, as set forth in 7.5.4 following may be applicable.

- (B) Multipoint Service

A Multipoint Service connects three or more customer designated premises through a Telephone Company hub. A mid-link is a channel between hubs, (i.e., bridging locations). Multipoint service is available with any number of mid-links in tandem; however, more than three mid-links in tandem may degrade the quality of service.

Special Access Service, Surcharge, if applicable, per Special Access Line. (See Section 7.5.4 following for exceptions.)

Multipoint service is provided in the following manner:

Serving wire centers where bridging (by service type) is available are referred to as Hubs.

Advice No. 03-28

Issued July 23, 2003 Effective August 23, 2003
Issued By CENTURYTEL OF WASHINGTON, INC. d/b/a CenturyTel
 P.O. Box 9901, Vancouver, WA
By Pamela Donovan Title Supervisor, Tariffs

(C)

ACCESS SERVICE

7. Special Access Service (Cont'd)
7.1 General (Cont'd)
7.1.4 Service Configurations (Cont'd)

(B) Multipoint Service (Cont'd)

The customer will specify the bridging serving wire center (i.e., Hub), selected to the Telephone Company. These Hub locations are identified in Section 15.

Service will be priced as provided.

Special Transport from the customer serving wire center to the bridging serving wire center (may also be customer designated premise.)

Optional facility interface combination per customer premises bridged. The facility interfaces at the customer premises do not have to be the same at each customer designated premises on a multipoint service, but communications can only be provided between compatible channel interfaces. The rates to be applied at the customer premises are those for the facility interface combination with the highest monthly rates at the initial installation of service.

Special Transport from the bridging serving wire center to the customer serving wire center, if required.

Special Access Line from the customer serving wire center to customer designated premises (per location).

Special Access Service Surcharge if applicable, (per customer premises). (See Section (B) for exceptions.)

Optional miscellaneous functions consist of equipment placed on a basic voice grade channel to improve circuit characteristic, i.e. gain, conditioning, bridging, hubbing.

Advice No. 03-28

Issued July 23, 2003 Effective August 23, 2003
Issued By CENTURYTEL OF WASHINGTON, INC. d/b/a CenturyTel
 P.O. Box 9901, Vancouver, WA
By Pamela Donovan Title Supervisor, Tariffs

(C)

ACCESS SERVICE

- 7. Special Access Service (Cont'd)
- 7.1 General (Cont'd)
- 7.1.4 Service Configurations (Cont'd)

(B) Multipoint Service (Cont'd)

As each additional leg is added to an existing multipoint service, additional Special Transport, an optional customer designated premise facility interface, an optional miscellaneous function, a Special Access Line and a Special Access Service Surcharge may be charged to the customer as required. If another bridge is connected, additional Special Transport, optional customer facility interface(s), an optional miscellaneous function, Special Access Line(s) and a Special Access Service Surcharge may be charged to the customer as required.

(C)

CT - Channel Termination (and Mileage charge, if applicable)

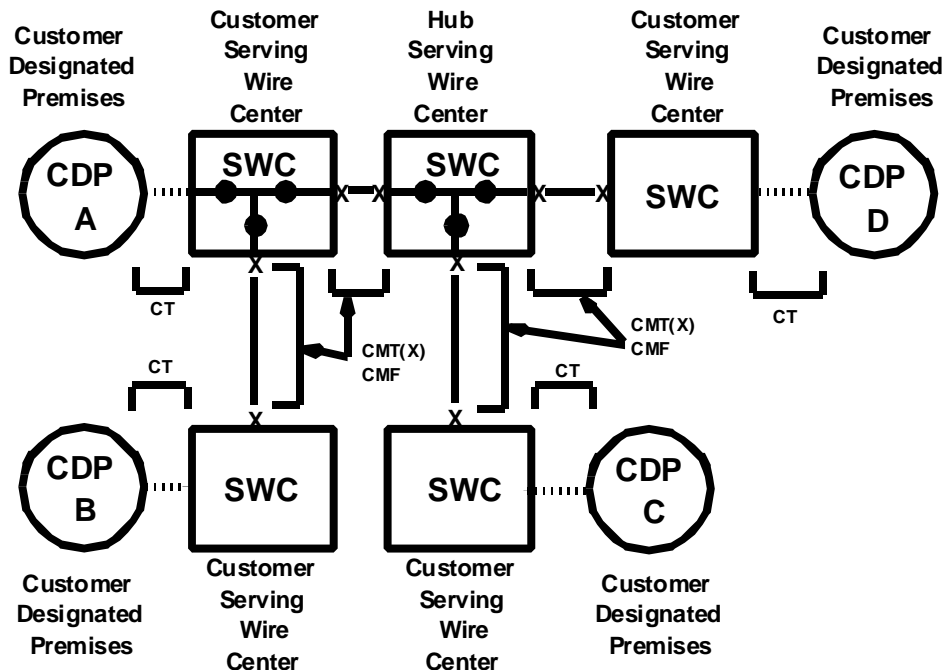

CMT - Channel Mileage Termination
 CMF - Channel Mileage Facility
 - Bridging Port

Applicable rate elements are:

- Channel Terminations (4 applicable)
- Channel Mileage
- 2 Channel Mileage Terminations per Channel Mileage Facility section for a total of 8,
- plus
- 4 sections, Channel Mileage Facility per mile
- Bridging Optional Feature (6 applicable, i.e., each bridge port)

(C)

Advice No. 03-28

Issued July 23, 2003

Effective August 23, 2003

Issued By CENTURYTEL OF WASHINGTON, INC. d/b/a CenturyTel
 P.O. Box 9901, Vancouver, WA

(C)

By Pamela Donovan Title Supervisor, Tariffs

ACCESS SERVICE

7. Special Access Service (Cont'd)

7.1 General (Cont'd)

7.1.5 Alternate Use

Alternate Use occurs when a customer uses a service for different types of transmission. The customer may use a service in any beneficial manner. However, where technical or engineering changes are required to effectuate an alternative use, the Telephone Company will make such special arrangements available on an individual case basis.

The Telephone Company will review each request for alternate use on an individual case basis for specific technical protection parameters as set forth in Section 2.5. The customer specified arrangement required to transfer the service from one operation to the other (i.e., the transfer relay and control leads) will be rated and provided on an individual case basis and filed in Section 12., Specialized Service or Arrangements. The customer will pay the stated tariff rates for the Access Service rate elements ordered (i.e., miscellaneous function, Special Transport, Facility Interface Combination and Special Access Line).

7.1.6 Special Facilities Routing

An customer may request that the facilities used to provide Special Access Service be specially routed. The regulations, rates and charges for Special Facilities Routing (i.e., Avoidance, Diversity and Cable-Only) are as set forth in 11. following.

7.1.7 Design Layout Report

The Telephone Company will provide to the customer within twenty normal business days the make-up of the facilities and service provided under this tariff as Special Access to aid the customer in designing its overall service. This information will be provided in the form of a Design Layout Report. The Design Layout Report will be provided to the customer at no charge.

Advice No. 03-28

Issued July 23, 2003

Effective August 23, 2003

Issued By CENTURYTEL OF WASHINGTON, INC. d/b/a CenturyTel
P.O. Box 9901, Vancouver, WA

(C)

By Pamela Donovan Title Supervisor, Tariffs

ACCESS SERVICE

7. Special Access Service (Cont'd)

7.1 General (Cont'd)

7.1.8 Acceptance Testing

At no additional charge, the Telephone Company will, at the customers request, cooperatively test, at the time of installation, the following parameters:

For analog services, acceptance tests will include tests for loss, 3-tone slope, DC continuity, operational signaling, C-notched noise, frequency response, harmonic distortion, phase jitter, impulse noise, C-message noise, and delay distortion when these parameters are specified in the order for service. Additionally, for Voice Grade services, a balance (improved loss) test will be made if the customer has ordered the improved loss optional feature.

All other Access Service will be tested to the performance parameters specified for the individual services.

7.1.9 Ordering Options and Conditions

There is an ordering options available to a customer in the provision of Special Access Service. It is:

Access Order

This option is set forth in detail in 5. preceding, as are the conditions under which the options may be elected. Cancellation charges associated with this option are set forth in Sections 16, 17 and 18 following.

Advice No. 03-28

Issued July 23, 2003

Effective August 23, 2003

Issued By CENTURYTEL OF WASHINGTON, INC. d/b/a CenturyTel
P.O. Box 9901, Vancouver, WA

(C)

By Pamela Donovan Title Supervisor, Tariffs

ACCESS SERVICE

7. Special Access Service (Cont'd)

7.2 Technical Service Descriptions for Special Access Service

Special Access Service may be either analog or digital. Analog services are differentiated by spectrum and bandwidth. Digital services are differentiated by bit rate.

There are three major categories of analog service and two digital service. These are:

Analog: Narrowband
 Voice Grade
 Dedicated Access Line Service

Digital: High Capacity
 Digital Data

Each of these except Dedicated Access Line Service, are further broken down into a number of subcategories.

This section includes the technical service descriptions for each type of analog and digital service provided, typical applications for which each type of service can be used, the optional miscellaneous functions available with specific services, transmission performances and optional available facility interface (FI) combinations with which service can be provided. The optional facility interface codes are described in 7.3 following.

The Telephone Company will maintain existing transmission specifications on services installed prior to the effective date of this tariff, except that existing services with performance specifications exceeding the standards listed in this provision will be maintained at the performance levels specified in this tariff.

Advice No. 03-28

Issued July 23, 2003

Effective August 23, 2003

Issued By CENTURYTEL OF WASHINGTON, INC. d/b/a CenturyTel
 P.O. Box 9901, Vancouver, WA

(C)

By Pamela Donovan Title Supervisor, Tariffs

ACCESS SERVICE

7. Special Access Service (Cont'd)

7.2 Technical Service Descriptions for Special Access Service (Cont'd)

7.2.1 Analog Services

(A) Narrowband Services

(1) Narrowband 4 (NB4) Special Access Service

(a) Description

Special Access Service NB 4 provides a channel for transmission of asynchronous transitions between two current levels at rates up to 75 baud. This service is furnished for half- duplex or duplex operation on a two-point or multipoint configuration. Neither direct current continuity of this service nor the capability to transport continuous ly varying alternating current is assured.

(b) Illustrative Applications

Special Access Service NB4 is suitable for use as part of the facilities required to provide intra-state telecommunications services such as:

Telegraph Grade Facilities
Entrance Facility - Telegraph Grade
Extension Service - Telegraph Grade
Teletypewriter Service
Alarm Circuits
Control/Remote Metering - Telegraph Grade

(c) Optional Miscellaneous Functions

Central office bridging capability.

(d) Transmission Performance

Telegraph Distortion

Remedial action will be initiated whenever the telegraph distortion is observed to exceed 9%.

Advice No. 03-28

Issued July 23, 2003

Effective August 23, 2003

Issued By CENTURYTEL OF WASHINGTON, INC. d/b/a CenturyTel
P.O. Box 9901, Vancouver, WA

(C)

By Pamela Donovan Title Supervisor, Tariffs

ACCESS SERVICE

7. Special Access Service (Cont'd)
 7.2 Technical Service Descriptions for Special Access Service (Cont'd)
 7.2.1 Analog Services (Cont'd)
 (A) Narrowband Services (Cont'd)
 (1) Narrowband 4 (NB4) Special Access Service (Cont'd)
 (e) Available Optional Facility Interface Combinations

Compatible FI Combinations

2DB2-43+	2TT2-2
2DB2-43+	4TT2-2
2DB2-43+	4TT2-2
4DB2-43+	2TT2-6
4DB2-43+	2TT2-6

+ Supplemental Channel Assignment information required.

Advice No. 03-28

Issued July 23, 2003

Effective August 23, 2003

Issued By CENTURYTEL OF WASHINGTON, INC. d/b/a CenturyTel
 P.O. Box 9901, Vancouver, WA

(C)

By Pamela Donovan

Title Supervisor, Tariffs

ACCESS SERVICE

7. Special Access Service (Cont'd)
7.2 Technical Service Descriptions for Special Access Service (Cont'd)
7.2.1 Analog Services (Cont'd)
(A) Narrowband Services (Cont'd)
(2) Narrowband 5 (NB5) Special Access Service

(a) Description

Special Access Service NB5 provides a channel for transmission of asynchronous transitions between two current levels at rates up to 150 baud. This service is furnished for half-duplex or duplex operation on a two-point or multipoint configuration. Neither direct current continuity of this service nor the capability to transport continuously varying alternating currents is assured.

(b) Illustrative Applications

Special Access Service NB5 is suitable for use as part of the facilities required to provide intra-state telecommunications services such as:

Extension Service - Telegraph Grade
Teletypewriter Service
Alarm Circuits
Type II Telegraph
Control/Remote Metering - Telegraph Grade

(c) Optional Miscellaneous Functions

Central office bridging capability.

(d) Transmission Performance

Telegraph Distortion

Remedial action will be initiated whenever the telegraph distortion is observed to exceed 12%.

Advice No. 03-28

Issued July 23, 2003

Effective August 23, 2003

Issued By CENTURYTEL OF WASHINGTON, INC. d/b/a CenturyTel
P.O. Box 9901, Vancouver, WA

(C)

By Pamela Donovan Title Supervisor, Tariffs

ACCESS SERVICE

7. Special Access Service (Cont'd)
 7.2 Technical Service Descriptions for Special Access Service (Cont'd)
 7.2.1 Analog Services (Cont'd)
 (A) Narrowband Services (Cont'd)
 (2) Narrowband 5 (NB5) Special Access Service (Cont'd)
 (e) Available Optional Facility Interface Combinations

Compatible FI Combinations

2DB2-10	10IA2
4DB2-10	10IA2
2DB2-43+	10IA2
4DB2-43+	10IA2

(B) Voice Grade Service

Basic voice grade facilities are unconditioned facilities capable of transmitting voice or data signals within the frequency band of approximately 300 Hz to 3000 Hz. These facilities are furnished on a two-point or multipoint basis and may be two-wire or four-wire at the points of termination. Optional functions and features may be added, at applicable charges, to enhance the operational capabilities of the facilities.

(1) Basic Voice Grade Special Access Service

(a) Description

Special Access Service provides a channel for voice frequency transmission capability. Usable frequencies are nominally 300 to 3000 Hz between customer and customer designated

+ Supplemental Channel Assignment information required.

Advice No. 03-28

Issued July 23, 2003

Effective August 23, 2003

Issued By CENTURYTEL OF WASHINGTON, INC. d/b/a CenturyTel
 P.O. Box 9901, Vancouver, WA

(C)

By Pamela Donovan Title Supervisor, Tariffs

ACCESS SERVICE

7. Special Access Service (Cont'd)
 7.2 Technical Service Descriptions for Special Access Service (Cont'd)
 7.2.1 Analog Services (Cont'd)
 (B) Voice Grade Services (Cont'd)
 (1) Basic Voice Grade Special Access Service (Cont'd)
 (d) Transmission Performance

C-Message Noise

The C-Message Noise shall be less than:

<u>Channel Mileage (mi)</u>	<u>Limit (dBmCO)</u> <u>Type VG</u>
0 - 50	32
51 - 100	33
101 - 200	35
201 - 400	37
401 - 1000	39

Echo Control

Echo Control, identified as Equal Level Echo Path Loss at four-wire interfaces or Return Loss at two-wire interfaces, and expressed as Echo Return Loss and Singing Return Loss, at the customer designated premises shall not be less than the following limits:

Advice No. 03-28

Issued July 23, 2003

Effective August 23, 2003

Issued By CENTURYTEL OF WASHINGTON, INC. d/b/a CenturyTel
 P.O. Box 9901, Vancouver, WA

(C)

By Pamela Donovan Title Supervisor, Tariffs

ACCESS SERVICE

7. Special Access Service (Cont'd)
 7.2 Technical Service Descriptions for Special Access Service (Cont'd)
 7.2.1 Analog Services (Cont'd)
 (B) Voice Grade Services (Cont'd)
 (1) Basic Voice Grade Special Access Service (Cont'd)
 (d) Transmission Performance (Cont'd)

Improved Return Loss

The Return Loss (RL), expressed as Echo Return Loss (ERL) and Singing Return Loss (SRL), on two-wire ports of a four-wire point of interface shall be equal to or greater than:

<u>Standard RL</u>	<u>Improved RL</u>
ERL 5 dB	ERL 20 dB
SRL 2.5 dB	SRL 13.5 dB

Loss Variation

The long term loss variation from the nominal 1004 Hz EML shall not exceed ± 4.0 dB.

Attenuation Distortion

The attenuation distortion between 404 Hz and 2804 Hz shall be within -2.0 dB and +10.0 dB with reference to the loss at 1004 Hz (minus equals less loss, plus equals more loss). The attenuation distortion between 504 Hz and 2504 Hz shall be within -2.0 dB and +8.0 dB and between 304 Hz and 3004 Hz shall be within -3.0 dB and +12.0 db.

- (e) Available Optional Facility Interface Combinations

Basic Voice Grade is also available with various chargeable optional facility interface combinations. These combinations are set forth in 7.2.1(B)(13) following.

Advice No. 03-28

Issued July 23, 2003

Effective August 23, 2003

Issued By CENTURYTEL OF WASHINGTON, INC. d/b/a CenturyTel
 P.O. Box 9901, Vancouver, WA

(C)

By Pamela Donovan Title Supervisor, Tariffs

ACCESS SERVICE

7. Special Access Service (Cont'd)
7.2 Technical Service Descriptions for Special Access Service (Cont'd)
7.2.1 Analog Services (Cont'd)
(B) Voice Grade Services (Cont'd)
(2) Dedicated Access Line Service (DALs) (Cont'd)

(c) Optional Features

Two-Wire Improved Voice Transmission Performance (guaranteed performance levels are set forth in (d)(ii) following).

Four-Wire Improved Voice Transmission Performance (guaranteed performance levels are set forth in (d)(iii) following).

Data Transmission Performance (guaranteed performance levels are set forth in (4)(iii) following).

Certain other features which may be provided in connection with Dedicated Access Line Service are available under the Telephone Company's local and/or general exchange service tariffs. These are:

End user access to a Telephone Company test lines
Speed Calling
Remote Call Forwarding
Directory Numbers (with trunk side terminations)

(d) Transmission Performance

(i) Standard Transmission Performance

Loss Deviation

The maximum Loss Deviation of the 1004 Hz loss relative to the Expected Measured Loss (EML) is ± 4.0 dB.

Advice No. 03-28

Issued July 23, 2003

Effective August 23, 2003

Issued By CENTURYTEL OF WASHINGTON, INC. d/b/a CenturyTel
P.O. Box 9901, Vancouver, WA

(C)

By Pamela Donovan Title Supervisor, Tariffs

ACCESS SERVICE

7. Special Access Service (Cont'd)
 7.2 Technical Service Descriptions for Special Access Service (Cont'd)
 7.2.1 Analog Services (Cont'd)
 (B) Voice Grade Services (Cont'd)
 (2) Dedicated Access Line Service (DALs) (Cont'd)
 (d) Transmission Performance (Cont'd)
 (i) Standard Transmission Performance (Cont'd)

Attenuation Distortion

The maximum Attenuation Distortion in the 404 to 2804 Hz frequency band relative to the loss at 1004 Hz is -3.0 dB to +9.0 dB.

C-Message Noise

The maximum C-Message Noise for the transmission path at the route miles listed is less than:

<u>Route Miles</u>	<u>C-Message Noise</u>
Less than 50	35 dBrnCO
51 to 100	37 dBrnCO
101 to 200	40 dBrnCO
201 to 400	43 dBrnCO
401 to 1000	45 dBrnCO

Echo Path Loss

When provided in association with a two-wire interface, the Echo Path Loss, expressed as Echo Return Loss (ERL) and Singing Return Loss (SRL), is equal to or greater than:

ERL 6.0 dB
 SRL 3.0 dB

Advice No. 03-28

Issued July 23, 2003

Effective August 23, 2003

Issued By CENTURYTEL OF WASHINGTON, INC. d/b/a CenturyTel
 P.O. Box 9901, Vancouver, WA

(C)

By Pamela Donovan Title Supervisor, Tariffs

ACCESS SERVICE

7. Special Access Service (Cont'd)
 7.2 Technical Service Descriptions for Special Access Service (Cont'd)
 7.2.1 Analog Services (Cont'd)
 (B) Voice Grade Services (Cont'd)
 (2) Dedicated Access Line Service (DALs) (Cont'd)
 (d) Transmission Performance (Cont'd)
 (iii) Four-Wire Improved Voice Transmission Performance

Loss Deviation

The maximum Loss Deviation of the 1004 Hz loss relative to the Expected Measured Loss (EML) is -4.0 dB to +4.0 dB.

Attenuation Distortion

The maximum Attenuation Distortion in the 404 to 2804 Hz frequency band relative to the loss at 1004 Hz is -2.0 dB to +6.0 dB.

C-Message Noise

The maximum C-Message Noise for the transmission path at the route miles listed is less than:

<u>Route Miles</u>	<u>C-Message Noise</u>
Less than 50	35 dBrnCO
51 to 100	37 dBrnCO
101 to 200	40 dBrnCO
201 to 400	43 dBrnCO
401 to 1000	45 dBrnCO

Echo Path Loss

The Echo Path Loss, expressed as Echo Return Loss (ERL) and Singing Return Loss (SRL), is equal to or greater than:

ERL 16.0 dB
 SRL 11.0 dB

Advice No. 03-28

Issued July 23, 2003

Effective August 23, 2003

Issued By CENTURYTEL OF WASHINGTON, INC. d/b/a CenturyTel
 P.O. Box 9901, Vancouver, WA

(C)

By Pamela Donovan Title Supervisor, Tariffs

ACCESS SERVICE

7. Special Access Service (Cont'd)
 7.2 Technical Service Descriptions for Special Access Service (Cont'd)
 7.2.1 Analog Services (Cont'd)
 (B) Voice Grade Services (Cont'd)
 (2) Dedicated Access Line Service (DALIS) (Cont'd)
 (d) Transmission Performance (Cont'd)

(iv) Data Transmission Parameters

Signal to C-Notched Noise Ratio

The minimum Signal-to-C-Notched Noise Ratio is 30 dB.

Envelope Delay Distortion

The maximum Envelope Delay Distortion for the frequency bands specified is:

1000 microseconds	604 to 2804 Hz
500 microseconds	1000 to 2404 Hz

Impulse Noise Counts

The Impulse Noise Counts exceeding a 67 dB_{rnCO} threshold in 15 minutes is no more than 15 counts.

Intermodulation Distortion

The Second Order (R2) and Third Order (R3) Intermodulation Distortion products are equal to or greater than:

Second Order (R2)	31 dB
Third Order (R3)	34 dB

Phase Jitter

The Phase Jitter over the 4 to 300 Hz frequency band is less than or equal to 7° peak-to-peak.

Advice No. 03-28

Issued July 23, 2003

Effective August 23, 2003

Issued By CENTURYTEL OF WASHINGTON, INC. d/b/a CenturyTel
 P.O. Box 9901, Vancouver, WA

(C)

By Pamela Donovan Title Supervisor, Tariffs

ACCESS SERVICE

7. Special Access Service (Cont'd)
7.2 Technical Service Descriptions for Special Access Service (Cont'd)
7.2.1 Analog Services (Cont'd)
(B) Voice Grade Service (Cont'd)
(2) Dedicated Access Line Service (DALSL) (Cont'd)
(d) Transmission Performance (Cont'd)

(iv) Data Transmission Parameters (Cont'd)

Frequency Shift

The maximum Frequency Shift does not exceed -2 to +2 Hz.

(e) Facility Interface (FI) Codes

Dedicated Access Line Service is available with either loop start or ground start facility inter-faces at the end user premises. The codes for these are as follows:

2LS2 or 2GS2

4LS2 or 4GS2

(f) Application of Rates

See 7.4.5 following, Rate Application Exception Rules, for the application of rates for this service.

Advice No. 03-28

Issued July 23, 2003

Effective August 23, 2003

Issued By CENTURYTEL OF WASHINGTON, INC. d/b/a CenturyTel
P.O. Box 9901, Vancouver, WA

(C)

By Pamela Donovan

Title Supervisor, Tariffs

ACCESS SERVICE

7. Special Access Service (Cont'd)
 7.2 Technical Services Descriptions for Special Access Service (Cont'd)
 7.2.1 Analog Services (Cont'd)
 (B) Voice Grade Services (Cont'd)
 (3) Available Optional Facility Interface (FI) Combinations

The following table shows the available optional facility interface (FI) combinations with which they may be ordered to supplement the basic voice grade service.

Compatible FI Combinations

4LS	4SF2
6LS2	4SF2
4N02	6DA2
4N02	4DA2
4N02	2DA2
4NO2	4N02
4NO2	2NO2
2NO2	2N02
2NO3	2N02
4SF2	4LS2
4SF3	4LS2
4SF2	2LS2
4SF2	2LS3
4SF3	4EA2-E
4SF3	4EA2-M
4SF2	4AC2
4SF2	2AC2

Advice No. 03-28

Issued July 23, 2003

Effective August 23, 2003

Issued By CENTURYTEL OF WASHINGTON, INC. d/b/a CenturyTel
 P.O. Box 9901, Vancouver, WA

(C)

By Pamela Donovan Title Supervisor, Tariffs

ACCESS SERVICE

7. Special Access Service (Cont'd)
7.2 Technical Service Descriptions for Special Access Service (Cont'd)
7.2.2 Digital Services

(A)

(B) Digital Data Access Services

Digital Data Access Services are only available via Telephone Company designated Digital Data Hubs.

(1) Digital Data Access 1 (DA1) Special Access Service

(a) Description

Special Access Service DA1 provides a channel for duplex four-wire transmission capability of serial synchronous data at the 2.4 kbps rate between customer designated premises. The service is synchronous with timing provided through the Telephone Company's facilities to the end user on the received bit stream. DA1 is available to any customer served by a wire center capable of providing digital service. Customers served by wire centers that are unable to provide digital service may receive DA1 service through an analog off-network extension which is provided as a Voice Grade Service as set forth in 7.2.1.(B) preceding. The customer may provide Channel Service-type equipment or other Network Channel Terminating Equipment associated with the Digital Data channel at the customer designated premises. The interim program for interconnection of such equipment is set forth in Technical Reference PUB AS No. 1.

(b) Illustrative Applications

Special Access Service DA1 is suitable for use as part of the facilities required to provide intrastate telecommunications services such as:

Digital Data - 2.4 kbps

(c) Optional Miscellaneous Functions

Central office bridging capability.

Advice No. 03-28

Issued July 23, 2003

Effective August 23, 2003

Issued By CENTURYTEL OF WASHINGTON, INC. d/b/a CenturyTel

P.O. Box 9901, Vancouver, WA

(C)

By Pamela Donovan

Title Supervisor, Tariffs

ACCESS SERVICE

7. Special Access Service (Cont'd)
7.2 Technical Service Descriptions for Special Access Service (Cont'd)
7.2.2 Digital Services (Cont'd)
(B) Digital Data Access Services (Cont'd)
(2) Digital Data Access 2 (DA2) Special Access Service (Cont'd)

(b) Illustrative Applications

Special Access Service DA2 is suitable for use as part of the facilities required to provide intrastate telecommunications services such as:

Digital Data - 4.8 kbps

(c) Optional Miscellaneous Functions

Central office bridging capability.

(d) Transmission Performance

Error-Free Seconds

While in service, the monthly average of the error-free seconds will be equal to or greater than 98.75%.

(e) Available Optional Facility Interface Combinations

Compatible FI Combinations

6DU5-48 6DU5-48

Advice No. 03-28

Issued July 23, 2003

Effective August 23, 2003

Issued By CENTURYTEL OF WASHINGTON, INC. d/b/a CenturyTel
P.O. Box 9901, Vancouver, WA

(C)

By Pamela Donovan Title Supervisor, Tariffs

ACCESS SERVICE

7. Special Access Service (Cont'd)
 7.2 Technical Service Descriptions for Special Access Service (Cont'd)
 7.2.2 Digital Services (Cont'd)
 (B) Digital Data Access Services (Cont'd)
 (4) Digital Data Access 4 (DA4) Special Access Service(Cont'd)

(b) Illustrative Applications

Special Access Service DA4 is suitable for use as part of the facilities required to provide interstate telecommunications services such as:

Digital Data - 56 kbps

(c) Optional Miscellaneous Functions

Central office bridging capability.

(d) Transmission Performance

Error-Free Seconds

While in service, the monthly average of the error-free seconds will be equal to or greater than 98.75%.

(e) Available Optional Facility Interface Combinations

<u>Customer</u>		<u>Customer Designated Premises</u>
6DU5-56		6DU5-56

Advice No. 03-28

Issued July 23, 2003

Effective August 23, 2003

Issued By CENTURYTEL OF WASHINGTON, INC. d/b/a CenturyTel
 P.O. Box 9901, Vancouver, WA

(C)

By Pamela Donovan Title Supervisor, Tariffs

ACCESS SERVICE

7. Special Access Service (Cont'd)
 7.2 Technical Service Descriptions for Special Access Service (Cont'd)
 7.2.2 Digital Services (Cont'd)

(C) High Capacity Service

(1) Description

A High Capacity channel is a channel for the transmission of nominal 1.544 mbps isynchronous serial data. High Capacity channels are provided between customer designated premises or between a customer designated premises and Telephone Company hub.

(2) Transmission Performance

A channel with technical specifications package HC1 will be capable of on error-free second performance of 98.75% over a continuous 24 hour period as measured at the 1.544 mbps rate through a CSU equivalent which is designed, manufactured and maintained to conform with the specifications contained in Technical Reference PUB 62411. Included in this offering is the framing format constraint with a D4 interface mode.

(3) Available Optional Facility Interface Combinations

<u>Customer</u>	<u>Customer Designated Premises</u>
4D59-15	4D59-15+

+ Available also as a cross connect of two individual channels of 1.544 mbps facilities at a Telephone Company hub.

Advice No. 03-28

Issued July 23, 2003

Effective August 23, 2003

Issued By CENTURYTEL OF WASHINGTON, INC. d/b/a CenturyTel
 P.O. Box 9901, Vancouver, WA

(C)

By Pamela Donovan Title Supervisor, Tariffs

ACCESS SERVICE

7. Special Access Service (Cont'd)
 7.2 Technical Service Descriptions for Special Access Service (Cont'd)
 7.2.3 Service Designator/Network Channel Code Conversion Table

The purpose of this table is to show the relationship between the service designator codes (e.g. VG, NB2, etc.) and the network channel codes that are used for various administrative purposes.

<u>Service Designator Code</u>	<u>Network Channel Code</u>
NB1	NT
NB2	NU
NB4	NW
NB5	NY
VG	LB
AP1	PE
AP2	PF
AP4	PK
DA1	XA
DA2	XB
DA3	XG
DA4	XH

Advice No. 03-28

Issued July 23, 2003

Effective August 23, 2003

Issued By CENTURYTEL OF WASHINGTON, INC. d/b/a CenturyTel
 P.O. Box 9901, Vancouver, WA

(C)

By Pamela Donovan Title Supervisor, Tariffs

ACCESS SERVICE

7. Special Access Service (Cont'd)

7.3 Optional Facility Interface Codes

This section explains the optional facility interface codes set forth in 7.2.1 and 7.2.2 preceding that the customer can specify when ordering Special Access Service. Included is an example which explains the specific characters of the code, a glossary of facility interface codes and impedance levels.

Example: If the customer specifies a 2DC8-3 facility interface at the premises, it is requesting the following:

- 2 = Number of physical wires at premises
- DC = Facility interface for direct current or voltage
- 8 = Variable impedance level
- 3 = facilities (DC continuity) for direct current/low frequency control signals or slow speed data (30 baud)

7.3.1 Glossary of Optional Facility Interface Codes and Options

<u>Code</u>	<u>Option</u>	<u>Definition</u>
AB -		accepts 20 Hz ringing signal at customer point of termination
AC -		accepts 20 Hz ringing signal at end user network interface
AH -		analog high capacity interface
	- B	60 kHz to 108 kHz (12 channels)
	- C	312 kHz to 552 kHz (60 channels)
	- D	564 kHz to 3084 kHz (600 channels)
DA -		data stream in VF frequency band at end user network interface
DB -		data stream in VF frequency band at customer location
	- 10	VF for NB4 and NB5
	- 43	VF for 43 Telegraph Carrier type signals, NB4 and NB5
DC -		direct current or voltage
	- 1	monitoring interface with series RC combination (McCulloch format)
	- 2	Telephone Company energized alarm channel
	- 3	Metallic facilities (DC continuity) for direct current/ low frequency control signals or slow speed data (30 baud)

Advice No. 03-28

Issued July 23, 2003

Effective August 23, 2003

Issued By CENTURYTEL OF WASHINGTON, INC. d/b/a CenturyTel
 P.O. Box 9901, Vancouver, WA

(C)

By Pamela Donovan Title Supervisor, Tariffs

ACCESS SERVICE

7. Special Access Service (Cont'd)
 7.3 Optional Facility Interface Codes (Cont'd)
 7.3.1 Glossary of Optional Facility Interface Codes and Options (Cont'd)

<u>Code</u>	<u>Option</u>	<u>Definition</u>
DD -		DATAPHONE Select-A-Station (and TABS) interface at customer point of termination
DE -		DATAPHONE Select-A-Station (and TABS) interface at the users NI
D0 -		digital interface at customer location at the digital signal level zero A (DS-0A)
DS -		digital hierarchy interface
	-15	1.544 mbps (DS1) format per PUB 41451 + D4
DU -		digital access interface at customer premises
	- 24	2.4 kbps
	- 48	4.8 kbps
	- 96	9.6 kbps
DX -		duplex signaling interface at customer POI
DY -		duplex signaling interface at end user NI
EA -		Type I, E&M Lead Signaling. Customer at POI or end user at NI originates on E Lead.

Advice No. 03-28

Issued July 23, 2003

Effective August 23, 2003

Issued By CENTURYTEL OF WASHINGTON, INC. d/b/a CenturyTel
 P.O. Box 9901, Vancouver, WA

(C)

By Pamela Donovan Title Supervisor, Tariffs

ACCESS SERVICE

7. Special Access Service (Cont'd)7.3 Optional Facility Interface Codes7.3.1 Glossary of Optional Facility Interface Codes and Options (Cont'd)

<u>Code</u>	<u>Option</u>	<u>Definition</u>
EA	- M	Type I, E&M Lead Signaling. Customer at POI or end user at NI originates on M Lead.
EB	-	Type II, E&M Lead Signaling. Customer at POI or end user at NI originates on E Lead.
EB	- M	Type II, E&M Lead Signaling. Customer at POI or end user at NI originates on M Lead.
EC	-	Type III, E&M signaling at customer terminal POI
EX	-	A tandem channel unit signaling for loop start of ground start and customer supplies open end (dial tone, etc.) functions.
EX	-	B tandem channel unit signaling for loop start of ground start and customer supplies closed end (dial pulsing, etc.) functions.
GO	-	ground start loop signaling - open end function by customer or end user
GS	-	ground start loop signaling - closed end function by customer or end user
IA	-	E.I.A. (25 pin RS-232)
LA	-	end user loop start loop signaling - Type A OPS registered port open end
LB	-	end user loop start loop signaling - Type B OPS registered port open end
LC	-	end user loop start loop signaling - Type C OPS registered port open end
LO	-	loop start loop signaling - open end function by customer or end user
LR	-	20 Hz automatic ringdown interface at customer with Telephone Company provided PLAR
LS	-	loop start loop signaling - closed end function by customer or end user
NO	-	no signaling interface, transmission only

Advice No. 03-28

Issued July 23, 2003

Effective August 23, 2003

Issued By CENTURYTEL OF WASHINGTON, INC. d/b/a CenturyTel
 P.O. Box 9901, Vancouver, WA

(C)

By Pamela Donovan Title Supervisor, Tariffs

ACCESS SERVICE

7. Special Access Service (Cont'd)7.3 Optional Facility Interface Codes7.3.1 Glossary of Optional Facility Interface Codes and Options (Cont'd)

<u>Code</u>	<u>Option</u>	<u>Definition</u>
PG	-	program transmission - no dc signaling
	- 1	nominal frequency from 50 to 15,000 Hz
	- 3	nominal frequency from 200 to 3,500 Hz
	- 5	nominal frequency from 100 to 5,000 Hz
	- 8	nominal frequency from 50 to 8,000 Hz
RV	-	0 reverse battery signaling, one way operation, originate by customer
RV	-	T reverse battery signaling, one way operation, terminate function by customer or end user
SF	-	single frequency signaling with VF band at either customer POI or customer designated premise NI
TF	-	telephotograph interface
TT	-	telegraph/teletypewriter interface at either customer POI or customer designated premise
	- 2	20.0 milliamperes
	- 3	3.0 milliamperes
	- 6	62.5 milliamperes

Advice No. 03-28

Issued July 23, 2003

Effective August 23, 2003

Issued By CENTURYTEL OF WASHINGTON, INC. d/b/a CenturyTel
 P.O. Box 9901, Vancouver, WA

(C)

By Pamela Donovan Title Supervisor, Tariffs

ACCESS SERVICE

7. Special Access Service (Cont'd)
7.4 Rate Regulations (Cont'd)
7.4.1 Types of Rates and Charges (Cont'd)
(C) Nonrecurring Charges (Cont'd)

(1) Installation of Service (Cont'd)

first service installed and a lower charge of ½ the basic charge for each additional identical service installed at the same customer premises. Nonrecurring charges for the installation of all services apply per service termination (i.e., customer location and customer designated premises). These are set forth in Sections 16, 17 and 18 following.

(2) Installation of Optional Features and Optional Functions

Nonrecurring charges apply for the installation of the optional features and functions available with Special Access Service and are set forth in Sections 16, 17 and 18 following. The charge applies whether the feature or function is installed coincident with the initial installation of service or at any time subsequent to the installation of the service.

(3) Service Rearrangements

Nonrecurring charges apply for service rearrangements. Service rearrangements are changes to existing services that do not result in a change to any of the following: (1) address of the customer location, (2) address of the end users premises, (3) type of service or (4) a WATS serving office. Changes of this nature constitute a discontinuance and start of service.

Advice No. 03-28

Issued July 23, 2003

Effective August 23, 2003

Issued By CENTURYTEL OF WASHINGTON, INC. d/b/a CenturyTel
P.O. Box 9901, Vancouver, WA

(C)

By Pamela Donovan

Title Supervisor, Tariffs

ACCESS SERVICE

7. Special Access Service (Cont'd)

7.4 Rate Regulations (Cont'd)

7.4.2 Surcharge for Special Access Service

(A) General

(1) In addition to the rates and charges described in 7.4.1 preceding, there is a monthly Special Access Surcharge that may apply to Special Access Service.

(a) The Special Access Surcharge will apply to each interstate Special Access Service that terminates on an end user's PBX or other device where, through a function of the device, the Special Access Service interconnects to the local exchange network. Interconnection functions include but are not limited to wiring and software functions, bridging, switching or patching of calls or stations. The Surcharge will apply irrespective of whether the interconnection function is performed in equipment located at the customer's premises or in a Centrex Co-type switch.

Special Access Service will be exempted from the Surcharge by the Telephone Company upon receipt of the customer's written certification for the following Special Access Service terminations:

- (1) an open-end termination in a Telephone Company switch of an FX line, including CCSA and CCSA equivalent ONALs or
- (2) an analog channel termination that is used for radio or television program transmission; or
- (3) a termination used for TELEX service; or

Advice No. 03-28

Issued July 23, 2003

Effective August 23, 2003

Issued By CENTURYTEL OF WASHINGTON, INC. d/b/a CenturyTel
P.O. Box 9901, Vancouver, WA

(C)

By Pamela Donovan Title Supervisor, Tariffs

ACCESS SERVICE

7. Special Access Service (Cont'd)

7.4 Rate Regulations (Cont'd)

7.4.2 Surcharge for Special Access Service (Cont'd)

(A) General (Cont'd)

(1) (Cont'd)

(a) (Cont'd)

- (4) a termination that by the nature of its operating characteristics could not make use of Tele phone Company common lines such as, terminations which are restricted through hardware or software; or
- (5) a termination that interconnects either directly or indirectly to the local exchange network where the usage is subject to Carrier Common Line charges such as, where the Special Access Service accesses only FGA and no local exchange lines, or Special Access Service between customer points of termination, or Special Access Service connecting CCSA or CSA-type equipment (inter-machine trunks); or
- (6) a termination that the customer certifies to the Telephone Company is not connected to a PBX or other device which interconnects the Special Access Service to a local exchange subscriber line.

Advice No. 03-28

Issued July 23, 2003

Effective August 23, 2003

Issued By CENTURYTEL OF WASHINGTON, INC. d/b/a CenturyTel
P.O. Box 9901, Vancouver, WA

(C)

By Pamela Donovan

Title Supervisor, Tariffs

ACCESS SERVICE

7. Special Access Service (Cont'd)

7.4 Rate Regulations (Cont'd)

7.4.2 Surcharge for Special Access Service (Cont'd)

(B) Exemption of Special Access Service

- (1) Special Access Services which are terminated as set forth in 7.4.2(A) preceding will be exempted from the Special Access Surcharge if the customer provides the Telephone Company with written exemption certification. The certification may be provided to the Telephone Company (1) at the time the Special Access Service is ordered or installed; (2) at such time as the service is reterminated to a device incapable of interconnection to local exchange facilities, or (3) at such time as the service becomes associated with a Switched Access Service that is subject to Carrier Common Line Charges.
- (2) The exemption certification is to be provided by the customer ordering the service. The certification must be signed by the customer or authorized representative and include the category of exemption, as set forth in 7.4.2(A) preceding, for each termination, and the date which the exemption is effective.
- (3) The customer shall also notify the Telephone Company when an exempted Special Access Service is changed or reterminated such that the exemption is no longer applicable.
- (4) The Telephone Company will work cooperatively with the customer to resolve any questions regarding the exemption certification. However, the Telephone Company may withhold exemption of the service until the dispute is resolved.

Advice No. 03-28

Issued July 23, 2003

Effective August 23, 2003

Issued By CENTURYTEL OF WASHINGTON, INC. d/b/a CenturyTel
P.O. Box 9901, Vancouver, WA

(C)

By Pamela Donovan Title Supervisor, Tariffs

ACCESS SERVICE

7. Special Access Service (Cont'd)7.4 Rate Regulations (Cont'd)7.4.2 Surcharge for Special Access Service (Cont'd)

(C) The surcharge applies to each channel of a Special Access Service and per voice grade equivalent service derived from a Special Access Service as shown in the following example:

<u>Special Access Service</u>	<u>Voice Grade Equivalent</u>	x	<u>Surcharge</u>	=	<u>Monthly Charge</u>
DS1	24	x	\$0	=	\$ 0.00

- (1) One surcharge will apply for each termination of a multipoint Special Access Service at a customer's designated premises, minus one.
- (2) The Telephone Company will bill the appropriate Special Access Surcharge to the ordering customer for each intrastate Special Access Service installed unless exemption certification is provided as set forth in 7.4.2(B) preceding.
- (3) If a written certification is not received at the time the Special Access Service is obtained, the surcharge will be applied. Exempt status will become effective on the certification date indicated by the customer, subject to the regulations set forth in (D) following.

(D) Crediting the Surcharge

- (1) The Telephone Company will cease billing the Special Access Surcharge when certification, as set forth in 7.4.2(A) preceding, is received. If the status of the Special Access Service was changed prior to receipt of the exemption certification, the Telephone Company will credit the customer's account, not to exceed ninety (90) days, based on the effective date of the change as specified by the customer in the letter of certification.

Advice No. 03-28

Issued July 23, 2003

Effective August 23, 2003

Issued By CENTURYTEL OF WASHINGTON, INC. d/b/a CenturyTel
 P.O. Box 9901, Vancouver, WA

(C)

By Pamela Donovan Title Supervisor, Tariffs

ACCESS SERVICE

7. Special Access Service (Cont'd)

7.4 Rate Regulations (Cont'd)

7.4.4 Moves (Cont'd)

(B) Moves To a Different Building

Moves to a different building will be treated as a discontinuance and start of service and all associated nonrecurring charges will apply. Minimum period requirements will be as of the initial start of service date.

7.4.5 Rate Application Exception Rules

- (A) When Dedicated Access Line Service is provided, the only rate elements which apply are Special Access Lines (SAL) between the end user premises and the end office (i.e., WATS serving office) and, when the end office is not a WATS serving office, Special Transport to extend the SAL to a WATS serving office. The nonrecurring charge for this service is that for the Special Access Line. A Special Access Service Surcharge as set forth in Sections 16, 17 and 18 following applies for each Dedicated Access Line Service installed.

Payment of any Special Access Surcharge, Message Station Equipment Recovery charge and inside wiring charge, billed on Dedicated Access Line facilities in service as of June 1, 1986, may be deferred, without penalty for up to ninety (90) days from the date of the first bill rendered for the Special Access Surcharge.

If appropriate exemption certification is not received by the Telephone Company by the end of ninety (90) day deferral period, the billed Special Access Surcharges, Message Station Equipment Recovery charge and the inside wiring charge will become due. These charges, if unpaid, will be subject to a late payment charge set forth in Section 2.4.1(B)(3). Customers who provide exemption certification within the first ninety (90) days will be given credit for the appropriate charges.

Advice No. 03-28

Issued July 23, 2003

Effective August 23, 2003

Issued By CENTURYTEL OF WASHINGTON, INC. d/b/a CenturyTel
P.O. Box 9901, Vancouver, WA

(C)

By Pamela Donovan Title Supervisor, Tariffs

ACCESS SERVICE

7. Special Access Service (Cont'd)

7.4 Rate Regulations (Cont'd)

7.4.5 Rate Application Exception Rules (Cont'd)

(A) (Cont'd)

When extensions (i.e., additional terminations of the service at another building in the same or a different LATA) are provided, they are rated in the following manner. Extensions within the LATA are provided as additional Special Access Lines and Special Transport as required. The Special Access Line nonrecurring charge will also apply. Extensions in different LATAs are rated as Special Transport (from the extension bridging point to the IC serving wire center), Access Connections and one half of the monthly recurring rates and non-recurring charges for the appropriate facility interface combination. No Special Access Service Surcharge applies to the extension service.

(B) ISDN Transport

The Telephone Company will provide ISDN Transport for customers from a telephone company providing ISDN to the desired customer premises, applying the ISDN Transport rates in Sections 16, 17 and 18 following. Access Line charges apply for the loop, in addition to any applicable interface charges. ISDN repeater rates will apply to the physical extension of the loop for each 18,000 foot segment beyond the first 18,000 feet from the central office.

(C) Reserved for Future Use

(D) Message Station Equipment Recovery Charge

The Message Station Equipment Recovery Charge is a charge to recover that portion of message station equipment that is assigned to Special Access Service.

Pursuant to CC Docket 83-1145 Memorandum Opinion and Order adopted by the Federal

Communications on November 8, 1984 and released on November 9, 1984, this charge is assessed only to those customers to which the Special Access Surcharge applies. The rate for the Message Station Equipment Recovery Charge is set forth in Sections 16, 17 and 18 following.

Advice No. 03-28

Issued July 23, 2003

Effective August 23, 2003

Issued By CENTURYTEL OF WASHINGTON, INC. d/b/a CenturyTel
 P.O. Box 9901, Vancouver, WA

(C)

By Pamela Donovan Title Supervisor, Tariffs

WN U-4

Fifth Revised Sheet No. 234
Cancels
Fourth Revised Sheet No. 234
CENTURYTEL OF WASHINGTON, INC.

(C)

ACCESS SERVICE

7. Special Access Service (Cont'd)

Advice No. 03-28

Issued July 23, 2003 Effective August 23, 2003
Issued By CENTURYTEL OF WASHINGTON, INC. d/b/a CenturyTel
 P.O. Box 9901, Vancouver, WA
By Pamela Donovan Title Supervisor, Tariffs

(C)

WN U-4

Third Revised Sheet No. 235
Cancels
Second Revised Sheet No. 235
CENTURYTEL OF WASHINGTON, INC.

(C)

ACCESS SERVICE

7. Special Access Service (Cont'd)

Advice No. 03-28

Issued July 23, 2003 Effective August 23, 2003
Issued By CENTURYTEL OF WASHINGTON, INC. d/b/a CenturyTel
 P.O. Box 9901, Vancouver, WA
By Pamela Donovan Title Supervisor, Tariffs

(C)

WN U-4

Fourth Revised Sheet No. 236
Cancels
Third Revised Sheet No. 236
CENTURYTEL OF WASHINGTON, INC.

(C)

ACCESS SERVICE

7. Special Access Service (Cont'd)

Advice No. 03-28

Issued July 23, 2003 Effective August 23, 2003
Issued By CENTURYTEL OF WASHINGTON, INC. d/b/a CenturyTel
 P.O. Box 9901, Vancouver, WA
By Pamela Donovan Title Supervisor, Tariffs

(C)

WN U-4

Fourth Revised Sheet No. 237
Cancels
Third Revised Sheet No. 237
CENTURYTEL OF WASHINGTON, INC.

(C)

ACCESS SERVICE

7. Special Access Service (Cont'd)

Advice No. 03-28

Issued July 23, 2003 Effective August 23, 2003
Issued By CENTURYTEL OF WASHINGTON, INC. d/b/a CenturyTel
 P.O. Box 9901, Vancouver, WA
By Pamela Donovan Title Supervisor, Tariffs

(C)

WN U-4

Third Revised Sheet No. 238
Cancels
Second Revised Sheet No. 238
CENTURYTEL OF WASHINGTON, INC.

(C)

ACCESS SERVICE

7. Special Access Service (Cont'd)

Advice No. 03-28

Issued July 23, 2003 Effective August 23, 2003
Issued By CENTURYTEL OF WASHINGTON, INC. d/b/a CenturyTel
 P.O. Box 9901, Vancouver, WA
By Pamela Donovan Title Supervisor, Tariffs

(C)

ACCESS SERVICE

7. Special Access Service (Cont'd)

7.5 Optional Features and Functions

(1) Voice Grade Services

- (a) Conditioning: Conditioning provides more specific transmission characteristics for data or telephoto services. There are two types of data conditioning, C-Type and DA-Type. C-Type conditioning controls attenuation distortion and envelope delay distortion; DA-Type conditioning controls the signal to C-notched noise ratio and intermodulation distortion. Telephoto conditioning controls attenuation distortion and envelope delay distortion.

Conditioning is charged for on a per two-point service or each section (i.e., midlink or end link) basis. The parameters listed for each type of conditioning apply from point of interface to network interface. For two-point services, the parameters apply to each service. For multipoint services, the parameters apply to any path between any two service terminal points. C-Type and DA-Type conditioning are available only for data services. C-Type and DA-Type conditioning may be combined on the same service.

Telephoto conditioning is available only for services.

Advice No. 03-28

Issued July 23, 2003

Effective August 23, 2003

Issued By CENTURYTEL OF WASHINGTON, INC. d/b/a CenturyTel
P.O. Box 9901, Vancouver, WA

(C)

By Pamela Donovan

Title Supervisor, Tariffs

ACCESS SERVICE

7. Special Access Service (Cont'd)
 7.5 Optional Features and Functions (Cont'd)
 (1) Voice Grade Services (Cont'd)
 (a) Conditioning: (Cont'd)
 (1) C-Type Conditioning:

For the additional control of attenuation distortion and envelope delay distortion on data services.

Attenuation Distortion
 (Frequency Response)
Relative to 1004 Hz

Frequency Variation
Range (Hz) (dB)
 400-2800 -1.0 to +2.0
 300-3000 -1.0 to +3.0
 300-3200 -2.0 to +6.0

Envelope Delay
Distortion
 Variation
 Frequency (micro-
Range(Hz) seconds)

1000-2600	100
800-2600	200
600-2600	300
500-2800	600
500-300	3000

Advice No. 03-28

Issued July 23, 2003

Effective August 23, 2003

Issued By CENTURYTEL OF WASHINGTON, INC. d/b/a CenturyTel
 P.O. Box 9901, Vancouver, WA

(C)

By Pamela Donovan Title Supervisor, Tariffs

ACCESS SERVICE

7. Special Access Service (Cont'd)
7.5 Optional Features and Functions (Cont'd)
(1) Voice Grade Services (Cont'd)
(a) Conditioning: (Cont'd)

(2) DA-Type Conditioning:

For the control of signal to C-notched noise ratio and intermodulation distortion on data services. DA-Type conditioning is available for two-point services or three-point multi-point services.

The signal to C-notched noise ratio and intermodulation distortion parameters for DA-Type conditioning are:

Signal to C-Notched Noise Ratio is equal to or greater than 32dB

Intermodulation distortion: Signal to second order modulation products (R2) is equal to or greater than 38dB

Signal to third order modulation products (R3) is equal to or greater than 42dB

When a service equipped with DA-Type conditioning is used for voice communications, the quality of the voice transmission may not be satisfactory.

Advice No. 03-28

Issued July 23, 2003

Effective August 23, 2003

Issued By CENTURYTEL OF WASHINGTON, INC. d/b/a CenturyTel
P.O. Box 9901, Vancouver, WA

(C)

By Pamela Donovan Title Supervisor, Tariffs

WN U-4

Third Revised Sheet No. 243
Cancels
Second Revised Sheet No. 243
CENTURYTEL OF WASHINGTON, INC.

(C)

ACCESS SERVICE

- 7. Special Access Service (Cont'd)
- 7.5 Optional Features and Functions (Cont'd)
- (1) Voice Grade Services (Cont'd)

Advice No. 03-28

Issued July 23, 2003 Effective August 23, 2003
Issued By CENTURYTEL OF WASHINGTON, INC. d/b/a CenturyTel
 P.O. Box 9901, Vancouver, WA
By Pamela Donovan Title Supervisor, Tariffs

(C)

ACCESS SERVICE

7. Special Access Service (Cont'd)
- 7.5 Optional Features and Functions (Cont'd)
- (1) Voice Grade Services (Cont'd)
- (b) Improved return loss for effective two-wire transmission at the customer designated premises. This option is applicable to all interfaces except E&M,SF and DX when the impedance code 2 is specified. The Improved Return loss parameters are set forth in the Transmission Performance descriptions of the services with which this option is available.
- (c) Improved return loss at four-wire point of interface, applicable to each two-wire leg of effective four-wire channel. The Improved Return Loss parameters are set forth in the Transmission Performance descriptions of the services with which this option is available.
- (d) Customer designated premises receive level within a range acceptable to the Telephone Company on effective four-wire transmission.

Advice No. 03-28

Issued July 23, 2003

Effective August 23, 2003

Issued By CENTURYTEL OF WASHINGTON, INC. d/b/a CenturyTel
P.O. Box 9901, Vancouver, WA

(C)

By Pamela Donovan Title Supervisor, Tariffs

WN U-4

Fifth Revised Sheet No. 246
Cancels
Fourth Revised Sheet No. 246
CENTURYTEL OF WASHINGTON, INC.

(C)

ACCESS SERVICE

7. Special Access Service (Cont'd)

Advice No. 03-28

Issued July 23, 2003 Effective August 23, 2003
Issued By CENTURYTEL OF WASHINGTON, INC. d/b/a CenturyTel
 P.O. Box 9901, Vancouver, WA
By Pamela Donovan Title Supervisor, Tariffs

(C)

WN U-4

Fourth Revised Sheet No. 247
Cancels
Third Revised Sheet No. 247
CENTURYTEL OF WASHINGTON, INC.

(C)

ACCESS SERVICE

7. Special Access Service (Cont'd)

Advice No. 03-28

Issued July 23, 2003 Effective August 23, 2003
Issued By CENTURYTEL OF WASHINGTON, INC. d/b/a CenturyTel
 P.O. Box 9901, Vancouver, WA
By Pamela Donovan Title Supervisor, Tariffs

(C)

ACCESS SERVICE

8. Billing and Collection Services

The Telephone Company will provide the following services:

- (A) Recording Service,
- (B) Billing Service,
- (C) Billing Analysis Service, and
- (D) Billing Information Service

8.1 Recording Service

The Telephone Company will provide Recording Service in association with the offering of Feature Groups C and D Switched Access Service for customer messages that can be recorded by Telephone Company provided automatic message accounting equipment. In addition, where the Telephone Company records the customer messages on manual tickets, the Telephone Company will provide Recording Service for the manual tickets and at offices where the Telephone Company provides Feature Group A Switched Access Service and has the ability to record the Feature Group A call detail with automatic message accounting equipment and mark the recorded call detail as Feature Group A call detail for a specific customer, the Telephone Company will provide Recording Service for Feature Group A Switched Access Service.

The Telephone Company will provide Recording Service in its operating territory. The minimum territory for which the Telephone Company will provide Recording Service is all the appropriately equipped offices in a state operating territory for which the customer has ordered Feature Group A, C or D Switched Access Service.

For Feature Group C and D Switched Access Service, the term "customer message" used herein denotes a completed intrastate call originated by a customer's end user. A customer message begins when answer supervision from the premise of the ordering customer is received by Telephone Company recording equipment indicating that the called party has answered. A message ends when disconnection supervision is received by Telephone Company recording equipment from either the premise of the ordering customer or the customer's end user premise from which the call originated.

Advice No. 03-28

Issued July 23, 2003

Effective August 23, 2003

Issued By CENTURYTEL OF WASHINGTON, INC. d/b/a CenturyTel
P.O. Box 9901, Vancouver, WA

(C)

By Pamela Donovan Title Supervisor, Tariffs

ACCESS SERVICE

8. Billing and Collection Services (Cont'd)

8.1 Recording Service (Cont'd)

8.1.1 General Description (Cont'd)

Provision of customer message detail is the provision of magnetic tapes containing the assembled and edited customer message detail and when requested by the customer, data-transmitting the assembled and edited customer message detail to the customer, sorting the message detail, and providing address information for the message detail. Except for lost or damaged records, the recorded detail will be available to the customer not more than five business days after the date all the detail requested by the customer was processed by the Telephone Company.

8.1.2 Undertaking of the Telephone Company

- (A) The Telephone Company will record all customer messages carried over Feature Groups C and D Switched Access Service that are available to Telephone Company provided recording equipment or operators. The Telephone Company will record all customer messages, including interLATA intrastate messages and intraLATA intrastate messages, carried over a Feature Group A Switched Access Service. Unavailable customer messages (i.e., certain Feature Group C operator and TSPS messages which are not accessible by Telephone Company provided recording equipment or operators) will not be recorded. The recording equipment will be provided at locations selected by the Telephone Company. Assembly and editing will be performed on all customer messages recorded during the billing period established by the Telephone Company. Except as set forth in 8.1.2(F) and 8.1.3 following, recorded message detail from previous billing periods will not be recovered and made available to the customer.
- (B) A standard format for the provision of the recorded customer message detail will be established by the Telephone Company and provided to the customer. If, in the course of Telephone Company business, it is necessary to change the format, the Telephone Company will notify the involved customers six months prior to the change.

Advice No. 03-28

Issued July 23, 2003

Effective August 23, 2003

Issued By CENTURYTEL OF WASHINGTON, INC. d/b/a CenturyTel
P.O. Box 9901, Vancouver, WA

(C)

By Pamela Donovan Title Supervisor, Tariffs

ACCESS SERVICE

8. Billing and Collection Services (Cont'd)

8.1 Recording Service (Cont'd)

8.1.3 Liability of the Telephone Company

Notwithstanding 2.1.3 preceding, the Telephone Company liability for Recording Service is as follows:

- (A) If customer message detail is not available because the Telephone Company lost or damaged tapes or incurred recording system outages, the Telephone Company will estimate the volume of lost customer messages and associated revenue based on previously known values. This estimated customer message volume will be included along with the customer message detail provided to the customer and/or provided for Message Processing Service. In such events the extent of the Telephone Company's liability for damages shall be limited to the granting of a corresponding credit adjustment to the customer amounts due to account for the unbillable revenue.
- (B) When the Telephone Company is notified that, due to error or omission, incomplete data have been provided to an customer, the Telephone Company will make every reasonable effort to locate and/or recover the data and provide new magnetic tapes to the customer at no additional charge. Such request to recover the data must be made within 30 days from the date the details were initially made available to the customer. If the data cannot be recovered, the extent of the Telephone Company's liability for damages shall be limited as set forth in (A) preceding.
- (C) In the absence of willful misconduct, no liability for damages to the customer or other person or entity other than as set forth in (A) and (B) preceding shall attach to the Telephone Company for its action or the conduct of its employees in providing Recording Service.

Advice No. 03-28

Issued July 23, 2003

Effective August 23, 2003

Issued By CENTURYTEL OF WASHINGTON, INC. d/b/a CenturyTel
P.O. Box 9901, Vancouver, WA

(C)

By Pamela Donovan Title Supervisor, Tariffs

ACCESS SERVICE

8. Billing and Collection Services (Cont'd)

8.1 Recording Service (Cont'd)

8.1.4 Obligations of the Customer

- (A) The customer shall order Recording Service under a Special Order for each state where the service is desired. The customer shall order Recording Service at least one month prior to the date when the customer message detail is to be recorded.
- (B) The customer shall order provision of recorded customer message detail without sorting or name and address information at least one month prior to the date when it wishes to receive the recorded message detail. However, the customer may wish to receive magnetic tapes of the recorded customer message detail without sorting or name and address information or have the recorded detail data-transmitted to a customer premise at some times and not at others. Therefore, change in the provision of recorded customer message detail without sorting and name and address information to the customer will be accommodated provided the customer gives two weeks advance written notification to the Telephone Company.

For recorded customer message detail with sorting and/or name and address information, the customer shall order the detail in accordance with the terms and conditions of the individual case basis established and filed in this tariff to cover the provision of recorded customer message detail with sorting and/or address information.

- (C) The premises of the ordering customer shall provide such signals as may be required for the proper operation of the Telephone Company's automatic message accounting equipment used to perform the detail recordings.

Advice No. 03-28

Issued July 23, 2003

Effective August 23, 2003

Issued By CENTURYTEL OF WASHINGTON, INC. d/b/a CenturyTel
P.O. Box 9901, Vancouver, WA

(C)

By Pamela Donovan Title Supervisor, Tariffs

ACCESS SERVICE

8. Billing and Collection Services (Cont'd)

8.1 Recording Service (Cont'd)

8.1.6 Rate Regulations

- (A) For each customer message recorded, the recording and the assembling and editing charges apply except when the customer orders Message Processing Service. When Message Processing Service as set forth in 8.2.1 following is ordered for the same state and month that Recording Service is ordered, the assembling and editing charge does not apply per customer message.

The charges for recording and for assembly and editing apply per message recorded and per message assembled and edited whether or not the customer's schedule of rates specifies billing on a per message basis or any other basis.

- (B) The per Special Order charge applies for each Special Order accepted by the Telephone Company for Recording Service.
- (C) When message detail, with or without sorting and/or address information is entered on a data file or magnetic tape for provision of message detail to a customer, the per tape charge applies for each data file or magnetic tape prepared, and the per record charge applies for each record processed. A record is a logical grouping of information as described in the programs that process the information and load the magnetic tapes or data file. The Telephone Company will determine the charges based on the number of data files or magnetic tapes prepared and on its count of the records processed. The number of records processed will be determined using the number of records input to or the number of records output from the programs that process the information and load the magnetic tapes or data file, whichever number of records is higher.

Advice No. 03-28

Issued July 23, 2003

Effective August 23, 2003

Issued By CENTURYTEL OF WASHINGTON, INC. d/b/a CenturyTel
P.O. Box 9901, Vancouver, WA

(C)

By Pamela Donovan

Title Supervisor, Tariffs

WN U-4

Third Revised Sheet No. 260
Cancels
Second Revised Sheet No. 260
CENTURYTEL OF WASHINGTON, INC.

(C)

ACCESS SERVICE

- 8. Billing and Collection Services (Cont'd)
- 8.1 Recording Service (Cont'd)

Advice No. 03-28

Issued July 23, 2003 Effective August 23, 2003
Issued By CENTURYTEL OF WASHINGTON, INC. d/b/a CenturyTel
 P.O. Box 9901, Vancouver, WA
By Pamela Donovan Title Supervisor, Tariffs

(C)

ACCESS SERVICE

8. Billing and Collection Services (Cont'd)

8.2 Billing Service

At the request of a customer, the Telephone Company with reasonable notice and reasonable effort will provide Billing Service.

The Telephone Company will provide Billing Service in its operating territory. The minimum territory for which the Telephone Company will provide Billing Service is its state operating territory when the Telephone Company supplies the input records at the customer's request. When the customer supplies the input records, the Telephone Company will process the input records supplied by the customer as set forth in 8.2.1 and 8.2.2 following.

The Telephone Company will provide two types of Billing Service: 1) Message Billing Service as set forth in 8.2.1, and 2) Private Line Billing Service as set forth in 8.2.2 following.

The Telephone Company will provide Bill Processing Service and Private Line Billing Service only on the condition that (1) it purchases the accounts receivable, if any, from the customer as set forth in 8.2.3 following or (2) the Telephone Company agrees to act as billing agent for the customer.

The Telephone Company will not render bills under this tariff for the provision and/or delivery of telegrams, flowers, gifts, wine or other like services that a customer offers.

Advice No. 03-28

Issued July 23, 2003

Effective August 23, 2003

Issued By CENTURYTEL OF WASHINGTON, INC. d/b/a CenturyTel
P.O. Box 9901, Vancouver, WA

(C)

By Pamela Donovan Title Supervisor, Tariffs

ACCESS SERVICE

8. Billing and Collection Services (Cont'd)

8.2 Billing Service (Cont'd)

8.2.1 Message Billing Service

Message Billing Service consists of Message Processing Service and Bill Processing Service. A customer may order Message Processing Service or Bill Processing Service or both services.

(A) General Description

(1) Message Processing Service

Message Processing Service is the transforming of the recorded customer call details into rated messages in preparation for billing. Message Processing Service includes initial data entry and rating of messages.

Initial data entry is the assembly of recorded customer call details into customer messages. This function includes editing and verification of recorded details to assure that the data required for rating are present.

Rating of customer messages is the computing of applicable charges for each customer message based on the customer provided schedule of rates. Rating also includes the preparation of customer message detail for input to Bill Processing Service, the customer, or other entities.

Further, rating is always performed and editing may be performed coincident with the implementation of a change in the customer's schedule of rates.

(2) Bill Processing Service

Bill Processing Service is the preparation of bills for message-billed service and bulk-billed service, mailing of

Advice No. 03-28

Issued July 23, 2003

Effective August 23, 2003

Issued By CENTURYTEL OF WASHINGTON, INC. d/b/a CenturyTel
P.O. Box 9901, Vancouver, WA

(C)

By Pamela Donovan Title Supervisor, Tariffs

ACCESS SERVICE

8. Billing and Collection Services (Cont'd)

8.2 Billing Service (Cont'd)

8.2.1 Message Billing Service (Cont'd)

(B) Undertaking of the Telephone Company (Cont'd)

(1) Message Processing Service (Cont'd)

- (b) The Telephone Company will provide Message Processing Service only for customer messages originating or recorded within the operating territory of the Telephone Company. The customer messages which the Telephone Company will process may be customer messages from Recording Service as set forth in 8.1 preceding or, at the direction of the customer, other customer messages which are chargeable in accordance with the rate schedule furnished by the customer.

Any sent-paid coin messages provided as input by the customer will be processed unless the customer specifies in writing that such messages are not to be processed. When such messages are processed message processing charges will apply. When such messages are not processed they may not be included in any message detail provided to the customer.

Advice No. 03-28

Issued July 23, 2003

Effective August 23, 2003

Issued By CENTURYTEL OF WASHINGTON, INC. d/b/a CenturyTel
P.O. Box 9901, Vancouver, WA

(C)

By Pamela Donovan Title Supervisor, Tariffs

ACCESS SERVICE

8. Billing and Collection Services (Cont'd)

8.2 Billing Service (Cont'd)

8.2.1 Message Billing Service (Cont'd)

(B) Undertaking of the Telephone Company (Cont'd)

(1) Message Processing Service (Cont'd)

- (c) A record of customer call details is required to provide Message Process Service. Where a customer subscribes to Recording Service as set forth in 8.1 preceding, those recorded details may be used as the input. Where the customer provides the call details, the records must be in the standard format established by the Telephone Company and delivered to the location specified by the Telephone Company. The charges as set forth in (G)(12) following will apply if the customer data-transmits its call details to the Telephone Company. If the customer provided records must be converted by the Telephone Company to the standard format, and the Telephone Company agrees to make the conversion, program development charges as set forth in (G)(3) following apply for the hours required to design, develop, test and maintain the necessary programs. The assembling and editing charge, as set forth in Sections 16, 17 and 18 following, applies in addition to all other charges for all such details converted by the Telephone Company. The Telephone Company will provide to the customer the precise details of the required standard format. If, in the course of Telephone Company business, it is necessary to change the standard format, the Telephone Company will provide notification to the involved customer's six months prior to the change. If the customer requests the customer provided call details be reprocessed by the Telephone Company because of an customer error, the Telephone Company will reprocess the customer provided call details and the appropriate charges as set forth in Sections 16, 17 and 18 following will apply.

Advice No. 03-28

Issued July 23, 2003

Effective August 23, 2003

Issued By CENTURYTEL OF WASHINGTON, INC. d/b/a CenturyTel
P.O. Box 9901, Vancouver, WA

(C)

By Pamela Donovan Title Supervisor, Tariffs

ACCESS SERVICE

8. Billing and Collection Services (Cont'd)
- 8.2 Billing Service (Cont'd)
- 8.2.1 Message Billing Service (Cont'd)
- (B) Undertaking of the Telephone Company (Cont'd)
- (1) Message Processing Service (Cont'd)
- (d) The Telephone Company will develop the customer's schedule of rates into a rating program. Program development charges, as set forth in (G)(3) following, apply for the hours required to design, develop, test and maintain the necessary programs.
- (e) Upon acceptance by the Telephone Company of a Special Order for Message Processing Service from a customer, the Telephone Company will determine the period of time to implement such service on an individual order basis.
- (f) Changes in the rate levels of customer charges to be billed will normally be implemented within 30 days after receipt of a Special Order from the customer requesting such changes. Such changes will require modifications of the rating program. Program development charges, as set forth in (G)(3) following, apply for the hours required to design, develop, test and the maintain the necessary program changes. If any customer message detail must be reprocessed in order to apply the rate changes, the appropriate message processing charges as set forth in (G)(1) and (G)(2) following apply for all customer messages reprocessed.
- (g) Changes in the rate structure for customer services to be billed also require a change in the rating program. When the Telephone Company determines that it can accommodate the changes, the conditions and the period of time required to make such changes will be determined on an individual order basis. Program development charges, as set forth in (G)(3) following, apply for the hours required to design, develop, test and maintain the necessary program changes. If any customer message detail must be reprocessed in order to apply the rate structure changes, the appropriate message processing charges as set forth in (G)(1) and (G)(2) following apply for all customer messages reprocessed.

Advice No. 03-28

Issued July 23, 2003

Effective August 23, 2003

Issued By CENTURYTEL OF WASHINGTON, INC. d/b/a CenturyTel
P.O. Box 9901, Vancouver, WA

(C)

By Pamela Donovan

Title Supervisor, Tariffs

ACCESS SERVICE

8. Billing and Collection Services (Cont'd)

8.2 Billing Service (Cont'd)

8.2.1 Message Billing Service (Cont'd)

(B) Undertaking of the Telephone Company (Cont'd)

(1) Message Processing Service (Cont'd)

- (h) Where the Telephone Company has rated customer messages which are to be billed to an end user by another Exchange Telephone Company, the Telephone Company will enter the customer messages on a magnetic tape or data file which can be used for data transmission of the details. When the customer has so arranged with an involved Exchange Telephone Company, the Telephone Company will transmit the rated customer message details to such other Exchange Telephone Company for billing to end users in its operating territories. When the customer does not have billing arrangements with an Exchange Telephone Company, rated customer messages for such an Exchange Telephone Company will be delivered to the customer. The charges as set forth in G(4) following apply to rated customer messages that are data-transmitted to the other Exchange Telephone Companies. The charges as set forth in (G)(5) following apply to rated customer messages that are delivered to the customer. When the customer message details are data-transmitted to the location designated by the customer, the data transmission charges will be determined on an individual case basis. Program development charges as set forth in (G)(3) following apply for the hours required to design, develop, test and maintain the necessary programs.
- (i) Where the rates for customer services have been implemented under an accounting order pending final approval from a regulatory agency, the Telephone Company will, upon written request from the customer, keep such records as may be required to make any adjustments to the end users as may be ordered by the regulatory agency. The charges for such a service will be determined on an individual case basis.

Advice No. 03-28

Issued July 23, 2003

Effective August 23, 2003

Issued By CENTURYTEL OF WASHINGTON, INC. d/b/a CenturyTel
P.O. Box 9901, Vancouver, WA

(C)

By Pamela Donovan Title Supervisor, Tariffs

ACCESS SERVICE

8. Billing and Collection Services (Cont'd)
8.2 Billing Service (Cont'd)
8.2.1 Message Billing Service (Cont'd)
(B) Undertaking of the Telephone Company (Cont'd)
(1) Message Processing Service (Cont'd)

- (j) The Telephone Company will, upon request, provide the customer the rated message detail.

The rated message detail will be provided on a request by request basis in a format similar to that used by the Telephone Company as input to Bill Processing Service. All rated customer message detail available to the Telephone Company will be provided to the customer. The rated customer message detail will furnish detail by specific end users, groups of end users, by office or by location.

The Telephone Company will provide the customer detail on a magnetic tape. The magnetic tapes will be provided without the return of previously supplied tapes. The Telephone Company will supply the magnetic tapes. Program development charges, as set forth in (G)(3) following, apply for the hours required to design, develop, test and maintain the necessary programs. When a magnetic tape is provided, the charges as set forth in (G)(5) following also apply.

Unless specified otherwise by the customer, the magnetic tapes will be sent to the customer using first class U.S. Mail service. However, the customer may pick up the magnetic tapes at a location designated by the Telephone Company or request the information on the magnetic tapes be data-transmitted to the customer. When the information is data-transmitted to a location designated by the customer, the data transmission charges will be determined on an individual basis.

Advice No. 03-28

Issued July 23, 2003

Effective August 23, 2003

Issued By CENTURYTEL OF WASHINGTON, INC. d/b/a CenturyTel
P.O. Box 9901, Vancouver, WA

(C)

By Pamela Donovan Title Supervisor, Tariffs

ACCESS SERVICE

8. Billing and Collection Services (Cont'd)
8.2 Billing Service (Cont'd)
8.2.1 Message Billing Service (Cont'd)
(B) Undertaking of the Telephone Company (Cont'd)
(2) Bill Processing Service (Cont'd)
(a) (Cont'd)

In addition, the Telephone Company will, in accordance with Telephone Company deposit regulations determine and collect a deposit from the end user for the customer service. The Telephone Company will, when necessary in accordance with the Telephone Company deposit regulations, determine and collect the service deposit when an end user account is established or for established accounts when the first customer message is posted to the end user account.

The Telephone Company will, when necessary in accordance with the Telephone Company deposit regulations, maintain a service deposit balance for each end user account. Service deposits will not be maintained by individual customer accounts but will be maintained for the end user account in general. The Telephone Company will provide the customer a copy of its service deposit regulations upon request from the customer.

- (b) The Telephone Company will provide Bill Processing Service for message-billed service, bulk-billed service and related rate elements which are posted to end user accounts located within the operating territory of the Telephone Company only. The Telephone Company will separate the rated customer messages into a message-billed group and a bulk-billed group for application of rates as set forth in (G) following.

Advice No. 03-28

Issued July 23, 2003

Effective August 23, 2003

Issued By CENTURYTEL OF WASHINGTON, INC. d/b/a CenturyTel
P.O. Box 9901, Vancouver, WA

(C)

By Pamela Donovan Title Supervisor, Tariffs

ACCESS SERVICE

8. Billing and Collection Services (Cont'd)
- 8.2 Billing Service (Cont'd)
- 8.2.1 Message Billing Service (Cont'd)
- (B) Undertaking of the Telephone Company (Cont'd)
- (2) Bill Processing Service (Cont'd)
- (g) The Telephone Company will provide Bill Processing Service only on the condition that (1) it purchases the accounts receivable from the customer as set forth in 8.2.3 following or (2) the Telephone Company agrees to act as billing agent for the customer.
- (h) The Telephone Company will not provide any information related to Bill Processing Service accounts under this section of the tariff. Bill Processing Services information may be obtained as set forth in 8.4 following.
- (i) The Telephone Company will, at the option of the customer, provide message-billed Bill Processing Service with or without inquiry and bulk-billed Bill Processing Service with or without inquiry. When the Telephone Company provides inquiry, the Telephone Company will be responsible for contacts and arrangements with the customer's end users concerning the billing, collecting, crediting and adjusting of the customer service charges, except prior customer balances due from end users, in accordance with written instructions furnished by the customer. At the request of the customer when the customer has ordered inquiry, the billed customer messages which are removed from an end user's bill in accordance with customer inquiry instructions will be reviewed for unauthorized use of customer service by Telephone Company message investigation groups for a period of up to 90 days after the billed customer message has been removed from an end user's bill. For any billed customer messages removed from an end user's bill in accordance with customer inquiry instructions, the Telephone Company will make appropriate adjustments to the customer's accounts receivable. When the Telephone Company provides Bill Processing Service without inquiry, all contacts from

Advice No. 03-28

Issued July 23, 2003

Effective August 23, 2003

Issued By CENTURYTEL OF WASHINGTON, INC. d/b/a CenturyTel
P.O. Box 9901, Vancouver, WA

(C)

By Pamela Donovan Title Supervisor, Tariffs

ACCESS SERVICE

8. Billing and Collection Services (Cont'd)
8.2 Billing Service (Cont'd)
8.2.1 Message Billing Service (Cont'd)
(B) Undertaking of the Telephone Company (Cont'd)
(2) Bill Processing Service (Cont'd)
(i) (Cont'd)

customer end users concerning the customer billed amounts will be referred to the customer, and the Telephone Company will only be responsible for contacts with customer's end users concerning the collection of customer service deposits and charges, except prior customer balances due from end users. Inquiry will only be provided when the customer is provided Bill Processing Service for the same state operating area.

- (j) The Telephone Company will accept customer gift certificates for payment from end users if the customer agrees in writing to redeem all such gift certificates. The format of the gift certificate must be acceptable to the Telephone Company.
- (k) Rated customer messages input to Bill Processing Service which the Telephone Company cannot bill for any reason will be reviewed by the Telephone Company's message investigation groups. Upon completion of the review, the billable messages will be posted and the appropriate charges, as set forth in (G)(7) and (G)(8) following, will apply. Unbillable messages will be handled in accordance with instructions that have been mutually determined by the Telephone Company and the customer. At the request of the customer the rated customer messages which cannot be billed to an end user will be reviewed for unauthorized use of customer service by Telephone Company message investigation groups for a period of up to 90 days after the rated customer message was processed.

Advice No. 03-28

Issued July 23, 2003

Effective August 23, 2003

Issued By CENTURYTEL OF WASHINGTON, INC. d/b/a CenturyTel
P.O. Box 9901, Vancouver, WA

(C)

By Pamela Donovan Title Supervisor, Tariffs

ACCESS SERVICE

8. Billing and Collection Services (Cont'd)
- 8.2 Billing Service (Cont'd)
- 8.2.1 Message Billing Service (Cont'd)
- (B) Undertaking of the Telephone Company (Cont'd)
- (2) Bill Processing Service (Cont'd)
- (l) The Telephone Company will post rated customer messages to the appropriate end user account when it identifies a customer message to be billed to an end user and will mark the appropriate end user account when a customer credit card is issued to an end user. The Telephone Company will bill to an end user other customer message-billed service charges, such as provision of a credit card, issuing of a credit card, blocking of third number billing, time and rate charges, and subscription charges when it receives an order for such services from a customer. Other customer message-related charges, such as directory assistance and DIAL-IT charges, will be billed to the end user based on customer message data received from Message Processing Service or from the customer. The Telephone Company will make adjustments to end user balances due to account for application of credits authorized by customer inquiry instructions and customer furnished statements.
- (m) The Telephone company will establish an end user account for customer bulk-billed service when it receives an order from an customer to perform such activity for a specific end user and will bill customer bulk-billed charges to the end user. The Telephone Company will bill other customer bulk-billed rate elements, such as provision of a bulk-billed service access line, installation of an access line and provision of an access line extension, when it receives an Special Order for such services from a customer. Other customer message-related charges for bulk-billed service, such as directory assistance and DIAL-IT charges, will be billed to the end user based on customer message data received from Message Processing Service or from the customer. The Telephone Company will make adjustments to end user balances due to account for application of credits authorized by customer inquiry instructions and customer furnished statements.

Advice No. 03-28

Issued July 23, 2003

Effective August 23, 2003

Issued By CENTURYTEL OF WASHINGTON, INC. d/b/a CenturyTel
P.O. Box 9901, Vancouver, WA

(C)

By Pamela Donovan Title Supervisor, Tariffs

ACCESS SERVICE

8. Billing and Collection Services (Cont'd)

8.2 Billing Service (Cont'd)

8.2.1 Message Billing Service (Cont'd)

(B) Undertaking of the Telephone Company (Cont'd)

(2) Bill Processing Service (Cont'd)

(n) Where the rates for customer services have been implemented under an accounting order pending final approval from a regulatory agency, the Telephone Company will, upon written request from the customer, keep such records as may be required to make any adjustments to the end users as may be ordered by the regulatory agency. The charges for such a service will be determined on an individual case basis.

(3) Message Billing Service Ordering

(a) The Telephone Company will provide Message Billing Services under a Special Order. For all Message Billing Service, other than establishment of or changes to end user account data (including credit card data), establishment of or changes to end user account rate elements and changes to end user balance due, the Message Billing Service Special Order charge as set forth in (G)(14) following will apply to orders accepted by the Telephone Company. The format of this Special Order will be specified by the Telephone Company.

Advice No. 03-28

Issued July 23, 2003

Effective August 23, 2003

Issued By CENTURYTEL OF WASHINGTON, INC. d/b/a CenturyTel
P.O. Box 9901, Vancouver, WA

(C)

By Pamela Donovan Title Supervisor, Tariffs

ACCESS SERVICE

8. Billing and Collection Services (Cont'd)
8.2 Billing Service (Cont'd)
8.2.1 Message Billing Service (Cont'd)
(B) Undertaking of the Telephone Company (Cont'd)
(3) Message Billing Service Ordering (Cont'd)

- (b) The Telephone Company will arrange with the customer to accept under a Special Order end user account information to establish and change end user account data (including credit card data), establish and change end user account rate elements and change end user rates and balances due. The methods, procedures and manner in which the end user account data and changes are forwarded to the Telephone Company must be agreeable to the Telephone Company. The charges to handle such Special orders will be determined on an individual case basis.

(C) Liability of the Telephone Company

Notwithstanding 2.1.3 preceding, the Telephone Company liability for Message Billing Service is as follows:

- (1) If Bill Processing Service detail is not available because the Telephone Company lost or damaged records or incurred processing systems outages, the Telephone Company will attempt to recover the lost customer detail. If the lost customer detail cannot be recovered and the Telephone Company recorded the details, the customer detail will be provided as set forth in 8.1.3(A) preceding. If the lost customer detail cannot be recovered and the customer provided the detail, the customer will be requested to resupply the detail. If the customer cannot resupply the detail, the detail will be estimated as set forth in 8.1.3(A) preceding. This recovered detail will be included in message detail provided to the customer when the customer orders such service and any recovered customer messages will be billed.

Advice No. 03-28

Issued July 23, 2003

Effective August 23, 2003

Issued By CENTURYTEL OF WASHINGTON, INC. d/b/a CenturyTel
P.O. Box 9901, Vancouver, WA

(C)

By Pamela Donovan Title Supervisor, Tariffs

ACCESS SERVICE

8. Billing and Collection Services (Cont'd)

8.2 Billing Service (Cont'd)

8.2.1 Message Billing Service (Cont'd)

(C) Liability of the Telephone Company (Cont'd)

- (2) When the Telephone Company is notified that, due to its error or omission, incomplete customer detail has been provided, as set forth in 8.2.1(B)(1)(i) preceding and/or 8.4 following, to a customer, the Telephone Company will make a reasonable effort to recover and provide the customer detail to the customer at no additional charge. Such request to recover the customer detail must be made within 30 days from the date the customer detail was initially made available to the customer. If the detail cannot be recovered, the extent of the Telephone Company's liability for damages shall be limited as set forth in 8.1.3(A) preceding.
- (3) If the Telephone Company finds, or is notified of, an error in billing to an end user, it will make a reasonable effort to correct the error and bill the appropriate end user within the limits permitted by laws of the state in which it provides the service. If the error is caused by the Telephone Company and the Telephone Company cannot bill the proper end user in a timely manner, the extent of the Telephone Company's liability for damages will be the known amount misbilled or when the amount misbilled is unknown, limited as set forth in 8.1.3(A).
- (4) In the absence of willful misconduct, no liability for damages to the customer or other person or entity other than as set forth in (1), (2) and (3) preceding shall attach to the Telephone Company for its action or the conduct of its employees in providing Message Billing Service.

Advice No. 03-28

Issued July 23, 2003

Effective August 23, 2003

Issued By CENTURYTEL OF WASHINGTON, INC. d/b/a CenturyTel
P.O. Box 9901, Vancouver, WA

(C)

By Pamela Donovan

Title Supervisor, Tariffs

ACCESS SERVICE

8. Billing and Collection Services (Cont'd)

8.2 Billing Service (Cont'd)

8.2.1 Message Billing Service (Cont'd)

(D) Obligations of the Customer (Cont'd)

- (2) When Message Processing Service is ordered, the customer shall furnish the Telephone Company, for each year in the order, an estimate of the number of messages (message capacity), including those messages which will be bulk-billed, to be processed.
- (3) The customer shall furnish all information necessary for the Telephone Company to provide the Message Billing Service, including any per month service charges applicable to an end user and an affidavit that states whether the customer service is subject to any Federal taxes and/or State taxes. When customer messages are to be billed by an entity other than the Telephone Company, the customer shall furnish written instructions as to how the rated customer messages are to be provided to that other entity. If the customer does not furnish complete instructions, all resulting unbillable messages will be delivered to the customer. The information shall be furnished by the customer in a timely manner.
- (4) The customer shall furnish to the Telephone Company a written schedule of its rates and charges in sufficient time to allow the Telephone Company to establish a rating program. The customer's rate structure must be consistent with established Telephone Company rating methodologies. The interval required to establish a rating program must be mutually agreeable to the Telephone Company and the customer.

Advice No. 03-28

Issued July 23, 2003

Effective August 23, 2003

Issued By CENTURYTEL OF WASHINGTON, INC. d/b/a CenturyTel
P.O. Box 9901, Vancouver, WA

(C)

By Pamela Donovan Title Supervisor, Tariffs

ACCESS SERVICE

8. Billing and Collection Services (Cont'd)

8.2 Billing Service (Cont'd)

8.2.1 Message Billing Service (Cont'd)

(D) Obligations of the Customer (Cont'd)

(5)

(6) The customer shall be responsible for all contact and arrangements, with its end users concerning the provision and maintenance of the customer's service including prior customer balances due from end users.

(7) When the customer orders message-billed or bulk-billed Bill Processing Service with inquiry, the customer shall furnish to the Telephone Company written instructions, which are agreeable to the Telephone Company, for the handling of end user questions about bills.

When the customer orders message-billed or bulk-billed Bill Processing Service without inquiry, the customer shall furnish the Telephone Company with written instructions as to where inquiries are to be referred.

When the customer does not order inquiry service and desires credit adjustments be made to the end user balance due, the customer shall furnish a statement for each end user account where the credit is desired. These statements shall show the customer message, the date the customer message was billed and the amount of the credit. These statements shall be furnished to the Telephone Company under a Special Order as set forth in (B)(3)(b) preceding.

The customer shall notify its end users through its tariff or other appropriate means when the customer handles the bill inquiries. The customer shall furnish the Telephone Company in writing all bill adjustment statements.

(8) The customer will immediately redeem all customer gift certificates the Telephone Company receives in payment for end user charges. The customer agrees to use a gift certificate format which is agreeable to the Telephone Company.

Advice No. 03-28

Issued July 23, 2003

Effective August 23, 2003

Issued By CENTURYTEL OF WASHINGTON, INC. d/b/a CenturyTel
 P.O. Box 9901, Vancouver, WA

(C)

By Pamela Donovan Title Supervisor, Tariffs

ACCESS SERVICE

8. Billing and Collection Services (Cont'd)

8.2 Billing Service (Cont'd)

8.2.1 Message Billing Service (Cont'd)

(D) Obligations of the Customer (Cont'd)

- (9) The customer agrees to permit the Telephone Company to, when necessary in accordance with Telephone Company deposit regulations, determine and collect customer service deposits from all end users of the customer's services for which the Telephone Company provides billing for the customer. The customer will notify its end users through its tariffs or other means that the Telephone Company will, when necessary in accordance with Telephone Company deposit regulations, determine and collect customer Service deposits. The customer will also include in its tariff and service arrangements and obtain regulatory concurrence for the Telephone Company deposit regulations that the Telephone Company will use to collect end user service deposits.
- (10) When the customer desires that a credit card be issued by the Telephone Company for an end user, the customer shall furnish the credit card information as specified by the Telephone Company. The information shall include a statement from the customer that the end user has requested the credit card. When the customer is notified by the Telephone Company that an customer credit card billing is discontinued, the customer shall notify the appropriate end user. The customer also agrees to be responsible for all charges to the discontinued credit card after receipt of notice of discontinuance and all charges to a customer credit card where the end user states in writing to the Telephone Company that the end user did not request the credit card.
- (11) When the customer furnishes recorded customer detail for Message Processing Service and/or rated customer message detail for Bill Processing Service, it shall be responsible to deliver the detail to the location specified by the Telephone Company and it shall retain a copy of the detail furnished for at least 90 days.

Advice No. 03-28

Issued July 23, 2003

Effective August 23, 2003

Issued By CENTURYTEL OF WASHINGTON, INC. d/b/a CenturyTel
P.O. Box 9901, Vancouver, WA

(C)

By Pamela Donovan Title Supervisor, Tariffs

ACCESS SERVICE

8. Billing and Collection Services (Cont'd)
8.2 Billing Service (Cont'd)
8.2.1 Message Billing Service (Cont'd)
(E) Payment Arrangements and Audit Provision
(1) Audit Provision

Upon written notice by the customer to the Telephone Company, the customer shall have the right, through its authorized representative, to examine and audit, during normal business hours and at reasonable intervals determined by the Telephone Company, all such records and accounts as may under recognized accounting practices contain information bearing upon the amount payable to the customer. Adjustment shall be made by the proper party to compensate for any errors or omissions disclosed by such examination or audit. Neither such right to examine and audit nor the right to receive such adjustment shall be affected by any statement to the contrary, appearing on checks or otherwise, unless such statement expressly waiving such right appears in a letter signed by the authorized representative of the party having such right and delivered to the other party.

Any information received or reviewed by the customer or its authorized representative during the audit is to be considered confidential and not to be distributed, provided or disclosed in any form to anyone not involved in the audit, nor is such information to be used for any other purpose.

(2) Minimum Period

The minimum period for which Message Billing Service is provided and for which charges apply is one year.

If the service is discontinued prior to the end of the period ordered, monthly charges apply for each remaining month and fraction of a month. The monthly charge will be one-twelfth of the minimum yearly charge.

Advice No. 03-28

Issued July 23, 2003

Effective August 23, 2003

Issued By CENTURYTEL OF WASHINGTON, INC. d/b/a CenturyTel
P.O. Box 9901, Vancouver, WA

(C)

By Pamela Donovan Title Supervisor, Tariffs

ACCESS SERVICE

8. Billing and Collection Services (Cont'd)
8.2 Billing Service (Cont'd)
8.2.1 Message Billing Service (Cont'd)
(E) Payment Arrangements and Audit Provision (Cont'd)
(3) Cancellation of a Special Order

A customer may cancel a Special Order for Message Billing Service on any date prior to the service date. The cancellation date is the date the Telephone Company receives written or verbal notice from the customer that the Special Order is to be cancelled. The verbal notice must be followed by written confirmation within 10 days. The service date for Message Billing Service is the date the customer and the Telephone Company mutually agree the service is to start. When a customer cancels a Special Order for Message Billing Service after the order date, but prior to the start of service, a charge equal to the Special Order charges, program development costs and any nonrecoverable capital costs incurred by the Telephone Company will apply to the customer.

(4) Changes to Special Orders

When a customer requests changes to a pending Special Order for Message Billing Service, such changes will be undertaken if they can be accommodated by the Telephone Company. A charge equal to any costs incurred by the Telephone Company because of the change will apply.

Advice No. 03-28

Issued July 23, 2003

Effective August 23, 2003

Issued By CENTURYTEL OF WASHINGTON, INC. d/b/a CenturyTel
P.O. Box 9901, Vancouver, WA

(C)

By Pamela Donovan

Title Supervisor, Tariffs

ACCESS SERVICE

8. Billing and Collection Services (Cont'd)

8.2 Billing Service (Cont'd)

8.2.1 Message Billing Service (Cont'd)

(F) Rate Regulations

- (1) The Message Processing and Bill Processing Service message charges apply during the yearly periods ordered by the customer. The Message Processing Service charges as set forth in (G)(1) following apply.

Advice No. 03-28

Issued July 23, 2003

Effective August 23, 2003

Issued By CENTURYTEL OF WASHINGTON, INC. d/b/a CenturyTel
P.O. Box 9901, Vancouver, WA

(C)

By Pamela Donovan Title Supervisor, Tariffs

ACCESS SERVICE

8. Billing and Collection Services (Cont'd)
8.2 Billing Service (Cont'd)
8.2.3 Purchase of Accounts Receivable (Cont'd)
(B) Recourse Adjustments

For each bill day, the Telephone Company will make recourse adjustments to the Total Current Amount Billed as follows:

(1) End User Adjustments

For each bill day, the Telephone Company will subtract from the Total Current Amount Billed the lawfully billed amounts which the Telephone Company removes from end users balances due in accordance with customer inquiry instructions. In addition, for each bill day, the Telephone Company will subtract from the Total Current Amount Billed an amount that equals the face value of any customer gift certificates (or its predecessor company's gift certificates) the Telephone Company has in its possession. The customer gift certificates the Telephone Company possesses will be returned to the customer.

(2) Telephone Company and Customer Adjustments

For each bill day, the Telephone Company will subtract from the Total Current Amount Billed bill amounts for end user bills which the Telephone Company delivers to the customer. In addition, for each bill day, the Telephone Company may make adjustments to the Total Current Amount Billed to accounts for amounts on statements received from the customer for additions or subtractions to an end user balance due for services billed in prior periods. Also, each bill day, the Telephone Company may make adjustments to the Total Current Amount Billed to account for additions and subtractions for customer or Telephone Company prior billing period errors.

Advice No. 03-28

Issued July 23, 2003

Effective August 23, 2003

Issued By CENTURYTEL OF WASHINGTON, INC. d/b/a CenturyTel
P.O. Box 9901, Vancouver, WA

(C)

By Pamela Donovan Title Supervisor, Tariffs

ACCESS SERVICE

8. Billing and Collection Services (Cont'd)
8.2 Billing Service (Cont'd)
8.2.3 Purchase of Accounts Receivable (Cont'd)
(B) Recourse Adjustments (Cont'd)
(3) Uncollectible Adjustments

For each bill day, the Telephone Company will subtract from the Total Current Amount billed an amount for uncollectibles. Uncollectibles are amounts billed by the Telephone Company to end users on Final Customer Bills that are added to the Uncollectible (realized) Accounts of the Telephone Company. The Telephone Company will determine the customer amount for uncollectibles for each bill day by multiplying the Total Current Amount Billed by the customer uncollectible factor rounded up to the nearest 1/1000th as determined in (a) or (b) following.

- (a) To determine the customer uncollectible factor, except for the initial three months that Bill Processing Services and/or Private Line Billing Service is provided to the customer, the Telephone Company will determine from its records the dollar amount lawfully billed on Final Customer Bills which, after standard collection efforts are completed, is added to its uncollectible (realized) accounts (uncollectible amount) for bills rendered to end users in the most recent 3 month period. This uncollectible amount will include adjustments to account for any payments received by the Telephone Company for outstanding Final Customer Bill amounts that pre-date the most recent 3 month period and any deposits held by the Telephone Company for services provided to the end users where Final Customer Bills have been rendered. The uncollectible amount (including where necessary the customer's or its predecessor company's history of uncollectible to develop a full recent 3 month period) will be used by the Telephone Company in an uncollectible apportionment study to determine the realized uncollectible amount for each customer which is

Advice No. 03-28

Issued July 23, 2003

Effective August 23, 2003

Issued By CENTURYTEL OF WASHINGTON, INC. d/b/a CenturyTel
P.O. Box 9901, Vancouver, WA

(C)

By Pamela Donovan Title Supervisor, Tariffs

ACCESS SERVICE

8. Billing and Collection Services (Cont'd)

8.2 Billing Service (Cont'd)

8.2.3 Purchase of Accounts Receivable (Cont'd)

(C) Payments of Net Purchase Amount to the Customer

- (1) The Telephone Company will purchase accounts receivable from the customer on each end user bill day for an amount (purchase amount) which equals the Total Current Amount Billed as set forth in (A) preceding after known Adjustments as set forth in (B) preceding have been made. On the date (payment date) determined by adding 31 days to the end user bill day, except as provided herein, the Telephone Company will remit payment to the customer for the purchase amount less additional adjustments as set forth in (B)(1) and (B)(2) preceding (net purchase amount) received by the Telephone Company prior to the payment date. Payment will be made in immediately available funds. Immediately available funds are funds which are available for use by the receiving party on the same day on which they are received and include U.S. Federal Reserve bank wire transfers, U.S. Federal Reserve notes (paper cash), U.S. coins, U.S. Postal Money Orders and New York Certificates of Deposit. If such payment date would cause payment to be due on a Saturday, Sunday or Holiday (i.e., New Year's Day, Independence Day, Labor Day, Thanksgiving Day, Christmas Day, the Second Tuesday in November and a day when Washington's Birthday, Memorial Day or Columbus Day is legally observed), payment for the net purchase amount will be due to the customer as follows:

If such payment date falls on a Sunday or on a Holiday which is observed on a Monday, the payment date shall be the first non-Holiday day following such Sunday or Holiday. If such payment date falls on a Saturday or on a Holiday which is observed on Tuesday, Wednesday, Thursday or Friday, the payment date shall be the last non-Holiday day preceding such Saturday or Holiday.

Advice No. 03-28

Issued July 23, 2003

Effective August 23, 2003

Issued By CENTURYTEL OF WASHINGTON, INC. d/b/a CenturyTel
P.O. Box 9901, Vancouver, WA

(C)

By Pamela Donovan

Title Supervisor, Tariffs

ACCESS SERVICE

8. Billing and Collection Services (Cont'd)

8.2 Billing Service (Cont'd)

8.2.3 Purchase of Accounts Receivable (Cont'd)

(C) Payments of Net Purchase Amount to the Customer (Cont'd)

(2) Further, if any portion of the net purchase amount is not received by the customer after the payment date as set forth in the (1) preceding, or if any portion of the net purchase amount is received by the customer in funds which are not immediately available to the customer, then a late payment penalty shall be due the customer. The late payment penalty shall be the portion of the net purchase amount received after the payment date times a late factor. The late factor shall be the lessor of:

- (a) the highest interest rate (in decimal value) which may be levied by law for commercial transactions in the state in which the Telephone Company provides Bill Processing Service to the customer, compounded daily for the number of days from the payment date to and including the date that the Telephone Company actually makes the payment to the customer, or
- (b) 0.000590 per day, compounded daily for the number of days from the payment date to and including the date that the Telephone Company actually makes the payment to the customer.

Any late payment penalty will be included with the next Telephone Company payment to the customer.

- (3) Also, if any adjustment that reduces an end user balance due is received by the Telephone Company from the customer after the date the Telephone Company billed the charges to be adjusted to the end user plus 45 days (billed plus date), then a late payment penalty shall be due the Telephone Company. The late payment penalty shall be the adjustment amount times a late factor. The late factor shall be the lessor of:

Advice No. 03-28

Issued July 23, 2003

Effective August 23, 2003

Issued By CENTURYTEL OF WASHINGTON, INC. d/b/a CenturyTel
P.O. Box 9901, Vancouver, WA

(C)

By Pamela Donovan Title Supervisor, Tariffs

ACCESS SERVICE

8. Billing and Collection Services (Cont'd)

8.2 Billing Service (Cont'd)

8.2.3 Purchase of Accounts Receivable (Cont'd)

(C) Payments of Net Purchase Amount to the Customer (Cont'd)

(3) (Cont'd)

- (a) the highest interest rate (in decimal value) which may be levied by law for commercial transactions in the state in which the Telephone Company provides Bill Processing Service and/or Private Line Billing to the customer, compounded daily for the number of days from the billed plus date to and including the date that the Telephone Company posts the end user account, or
- (b) 0.000590 per day, compounded daily for the number of days from the billed plus date to and including the date that the Telephone Company posts the end user account. Any late payment penalty will be included with the adjustment made by the Telephone Company to the customer's Total Current Amount Billed.

(D) Netting of Customer Access Service Charges and Net Purchase Amounts

When a payment for customer Access Service Charges under this tariff is due to the Telephone Company from the customer on the same payment date that a net purchase amount is due to the customer from the Telephone Company, the Telephone Company may, with at least a 31 day notice to the customer net the payment for customer Access Service Charges with the net purchase amount. The Telephone Company will pay the net amount to the customer on the payment date when such net amount is due the customer or require the customer to pay the Telephone Company the net amount when such net amount is due the Telephone Company. If either party does not make the payment on the payment date, a late payment penalty as set forth in (C) preceding or 2.4.1(B)(3) preceding, whichever is appropriate, applies.

Upon request from the customer, the Telephone Company will provide a copy of its methods and procedures used to determine the amounts named in this section (i.e., 8.2.3 Purchase of Accounts Receivable) to the authorized representative of the customer who is responsible for auditing these amounts.

Advice No. 03-28

Issued July 23, 2003

Effective August 23, 2003

Issued By CENTURYTEL OF WASHINGTON, INC. d/b/a CenturyTel
 P.O. Box 9901, Vancouver, WA

(C)

By Pamela Donovan Title Supervisor, Tariffs

ACCESS SERVICE

8. Billing and Collection Services (Cont'd)

8.2 Billing Service (Cont'd)

8.2.4 Billing Arrangements when the Telephone Company Acts as Billing Agent for the Customer

When the Telephone Company agrees to act as billing agent for the customer, the billing service, payment arrangements and ownership of the accounts receivable will be as follows:

- (A) The billing services, including the collection from end users of monies for the customer accounts receivable that arise from bills rendered by the Telephone Company to that customer's end users, provided by the Telephone Company will be as set forth in 8.2.1 and 8.2.2 preceding.
- (B) For the customer accounts receivable that arise from bills rendered by the Telephone Company to that customer's end users, the Total Current Amount Billed and the Recourse Adjustments will be determined as set forth in 8.2.3 preceding. The payment of the net monies due the customer will be handled as set forth in 8.2.3 (C) preceding.
- (C) The ownership of the customer accounts receivable will not be transferred by the customer to the Telephone Company. When the customer discontinues Billing Service provided under this tariff where the Telephone Company is acting as billing agent for the customer, the Telephone Company will determine and make a final payment to the customer as set forth in (B) preceding. This final payment shall be considered to be all of the remaining monies due the customer for the bills rendered to the customer's end users by the Telephone Company. When the Telephone Company discontinues billing the customer's end users for customer services, any deposits for customer services will be returned to the appropriate end user in accordance with Telephone Company final billing procedures.

Advice No. 03-28

Issued July 23, 2003

Effective August 23, 2003

Issued By CENTURYTEL OF WASHINGTON, INC. d/b/a CenturyTel
P.O. Box 9901, Vancouver, WA

(C)

By Pamela Donovan Title Supervisor, Tariffs

ACCESS SERVICE

8. Billing and Collection Services (Cont'd)

8.3 Billing Analysis Service

At the request of a customer which is a common carrier, the Telephone Company upon reasonable notice and with reasonable effort will provide Billing Analysis Service for detection, investigation and deterrence of billing evasion activities.

The term "billing evasion activities" used herein denotes Message Billing Abuse and/or Network Abuse. Such abuse is the use of an access line (e.g., end user line or trunk, Pay Telephone line or other access line or trunk provided by the Telephone Company) where there is intent to circumvent or evade the proper charges in whole or in part for use of telecommunications services over the access line, or to conceal the points of origin or termination of telecommunications services.

Such activities include bypass or circumvention of Telephone Company billing equipment, unauthorized use of Telephone Company and customer service offerings, and unauthorized use of Telephone Company facilities.

8.3.1 General Description

Billing Analysis Service is the provision of detection, investigation and deterrence of billing evasion activities.

Detection is the provision of equipment by the Telephone Company to identify and collect information on Network Abuse. Such equipment may be located in Telephone Company premises or offices or may be attached to access lines.

Investigation is the provision of investigative services to collect evidence to document that billing evasion activities are occurring, prepare reports, preserve evidence and supply expert witness analysis and testimony. Investigation also includes provision of services to coordinate the investigative activities between Exchange Telephone Companies and/or law enforcement agencies.

Deterrence is the contacting and interviewing of parties identified in billing evasion activities, the recovery of devices or materials used in billing evasion activities (where legally permitted), the service review for possible suspension of service over access lines identified in billing evasion activities and publicity assistance in publicizing billing evasion deterrence.

Advice No. 03-28

Issued July 23, 2003

Effective August 23, 2003

Issued By CENTURYTEL OF WASHINGTON, INC. d/b/a CenturyTel
P.O. Box 9901, Vancouver, WA

(C)

By Pamela Donovan Title Supervisor, Tariffs

ACCESS SERVICE

8. Billing and Collection Services (Cont'd)

8.3 Billing Analysis Service (Cont'd)

8.3.2 Undertaking of the Telephone Company

- (A) When Billing Analysis Service is ordered under a Special Order by an authorized Security representative of the customer, the Telephone Company will provide any one or all of the services as set forth in (B) through (D) following at rates and charges as set forth in Sections 16, 17 and 18 following.
- (B) Detection Service will be provided at any central office switch equipped to recognize and record irregular key pulse and multifrequency signals upon receipt of a Special Order from a customer specifying the central office(s) where detection service is requested. Subject to the agreement of the Telephone Company, special construction for the provision of central office equipment to recognize and record irregular key pulse and multifrequency signals may be undertaken at the request of authorized Security representative of the customer to meet the needs of the customer. Such Special construction will be provided on an individual case basis (ICB) when requested by the customer.
- (1) Reports of detection service results will be provided on an office-by-office or line-by-line basis at the request of the authorized Security Representative of the customer. On an office-by-office basis, a detection service report of any signal irregularities will be provided for the previous 60 days for all trunks equipped in the office (i.e. ESS control group). Alternatively, for an office requested by the customer, a line-by-line continuous scan for current signal irregularities will be provided. When the continuous line-by-line scan is provided, a weekly report of signal irregularities for the office involved will be furnished.
- (2) The detection service reports as set forth in (1) preceding will include, for a signaling irregularity observed, the following: (a) the calling NPA and telephone number (i.e., NXX-XXXX), (b) the called number (i.e., NPA and telephone number recorded by Telephone Company billing equipment) if available, (c) signaling irregularity data, (D) the holding

Advice No. 03-28

Issued July 23, 2003

Effective August 23, 2003

Issued By CENTURYTEL OF WASHINGTON, INC. d/b/a CenturyTel
P.O. Box 9901, Vancouver, WA

(C)

By Pamela Donovan Title Supervisor, Tariffs

ACCESS SERVICE

8. Billing and Collection Services (Cont'd)

8.3 Billing Analysis Service (Cont'd)

8.3.2 Undertaking of the Telephone Company (Cont'd)

(C) (Cont'd)

- (2) Collection of evidence is the gathering of information pertinent to the line, message, or party associated with the billing evasion activity specified by the authorized Security representative of the customer. Collection of evidence includes a written notification to the authorized Security representative of the customer of the results of such gathering efforts. The Telephone Company will determine the information provided in the written notification.
- (3) Subject to the agreement of the Telephone Company a detection and documentation scan on an individual line will be provided when an authorized Security representative of the customer provides a written request for such a scan. Provision of a detection and documentation scan on an individual line is the continuous scan of line for irregular signals and when an irregular signal is recognized, the collection by Telephone Company equipment of information to show an irregular signal and use of the line occurred. Any information collected during the continuous scan of a line will be considered the property of the Telephone Company. The Telephone Company will notify the customer of the results of the scan and will permit authorized Security representatives of the customer to review the results. The scan and any associated information will not be provided to any person or entity until the Telephone Company is requested to do so by subpoena or lawful demands. Any out of pocket payments for travel and/or other expenses of Telephone Company personnel will be billed to the customer.
- (4) Preparation of an affidavit and prosecutive summary is the written documentation of the evidence collected by the Telephone Company personnel who performed such activities.

Advice No. 03-28

Issued July 23, 2003

Effective August 23, 2003

Issued By CENTURYTEL OF WASHINGTON, INC. d/b/a CenturyTel
P.O. Box 9901, Vancouver, WA

(C)

By Pamela Donovan

Title Supervisor, Tariffs

ACCESS SERVICE

8. Billing and Collection Services (Cont'd)

8.3 Billing Analysis Service (Cont'd)

8.3.2 Undertaking of the Telephone Company (Cont'd)

(C) (Cont'd)

- (5) Preservation of evidence is the placement of the collected evidence in a secure location under the control of Telephone Company Security personnel for a period of up to two years. Such preservation of evidence will be continued beyond two years by the Telephone Company when requested by appropriate law enforcement agencies or the authorized Security representative of the customer. The charges for Preservation of Evidence as set forth in 8.3.7 (B) following will apply.
- (6) Assistance to law enforcement is the accompanying of duly authorized law enforcement personnel to a location where billing evasion activities have been determined to exist in order to identify billing evasion activity devices or materials. The Telephone Company personnel will provide such assistance to law enforcement personnel only after law enforcement involvement has been arranged by the customer, or under services as set forth in (10) following. If such assistance is required at locations outside the operating territory of the Telephone Company involved, any out of pocket payments for travel and/or other expenses of Telephone Company personnel will be billed to the customer, except to the extent that such expenses are paid by the judicial system.
- (7) Provision of expert witness analysis is the review, study and other technical support activities provided by Telephone Company experts to analyze and/or document whether devices and materials associated with an investigation furnished by the authorized Security representative of the customer or under the services as set forth in (10) following operate, perform or contain billing evasion activities. A written analysis report will be provided to the authorized Security representative of the customer. The expert will be selected by the Telephone Company.

Advice No. 03-28

Issued July 23, 2003

Effective August 23, 2003

Issued By CENTURYTEL OF WASHINGTON, INC. d/b/a CenturyTel
P.O. Box 9901, Vancouver, WA

(C)

By Pamela Donovan

Title Supervisor, Tariffs

ACCESS SERVICE

8. Billing and Collection Services (Cont'd)

8.3 Billing Analysis Service (Cont'd)

8.3.2 Undertaking of the Telephone Company (Cont'd)

(C) (Cont'd)

- (8) Provision of expert witness testimony is the preparation of testimony and the submission of such testimony in association with an investigation. A copy of the written testimony, if any, will be provided to the authorized Security representative of the customer. The expert witness will be selected by the Telephone Company. Any out of pocket payments for travel and/or other expenses of Telephone Company personnel will be billed to the customer.
- (9) Coordination of billing evasion investigative services between telephone companies is the referral of investigative information to other telephone company Security personnel, provision of billing evasion information to other telephone company security personnel, the collection of information from other telephone company security personnel, and the tracking, collecting and reporting of the results of such investigations to the authorized Security representative of the customer.
- (10) Coordination of billing evasion investigative activities of participating law enforcement agencies is the provision of billing evasion information to the law enforcement agencies, the collection of billing evasion information from the law enforcement agencies and the tracking, collecting and reporting of the results of such participation to the authorized Security representative of the customer. This coordination will be provided only upon receipt of written authorization from the authorized Security representative the customer.
- (11) Review of customer billing evasion deterrence control programs and related activities is advice to and/or training of customer personnel on billing evasion deterrence and preventive controls and the development of billing evasion deterrence and preventive control programs for the customer.

Advice No. 03-28

Issued July 23, 2003

Effective August 23, 2003

Issued By CENTURYTEL OF WASHINGTON, INC. d/b/a CenturyTel
P.O. Box 9901, Vancouver, WA

(C)

By Pamela Donovan Title Supervisor, Tariffs

ACCESS SERVICE

8. Billing and Collection Services (Cont'd)

8.3 Billing Analysis Service (Cont'd)

8.3.2 Undertaking of the Telephone Company (Cont'd)

(D) (Cont'd)

- (3) Service Review for possible suspension of Telephone Company service is the request for authority to suspend service from appropriate Telephone Company officers, notification to the end user that service will be suspended and, after review of the end user response, or lack thereof, suspension of service, if warranted, in the Telephone company's judgment.
- (4) Publicity assistance for publicizing billing evasion activity deterrence is the provision of information and personnel to aid in publicizing billing evasion activity deterrence. The Telephone Company will determine what information it will provide, if any, and will select the personnel and media, if any, to provide this service.

8.3.3 Liability of the Telephone Company

Notwithstanding 2.1.3 preceding, in the absence of willful misconduct, no liability for damages to the customer or other person or entity shall attach to the Telephone Company for its action or the conduct of its employees providing Billing Analysis Service.

Advice No. 03-28

Issued July 23, 2003

Effective August 23, 2003

Issued By CENTURYTEL OF WASHINGTON, INC. d/b/a CenturyTel
P.O. Box 9901, Vancouver, WA

(C)

By Pamela Donovan Title Supervisor, Tariffs

ACCESS SERVICE

8. Billing and Collection Services (Cont'd)

8.3 Billing Analysis Service (Cont'd)

8.3.4 Obligations of the Customer

- (A) The authorized Security representative of the customer shall order all Billing Analysis Service under a Special Order. The authorized Security representative of the customer shall order those Billing Analysis Services it wishes to receive.
- (B) With each order, the customer shall designate and identify its authorized Security representative who will be responsible to protect the information and to whom the Billing Analysis Service information will be provided. The customer shall assure and take every effort to make sure the Billing Analysis System information is provided to and used only by authorized personnel involved in billing evasion activity matters.
- (C) When Billing Analysis Service Investigation is ordered, the authorized Security representative of the customer shall furnish all known details of the billing evasion activities, including the access lines, parties or messages to be investigated, and shall furnish all necessary end user information it possesses to the Telephone Company Security personnel. The specification of the access line, party or message to be investigated shall be in writing by the authorized Security representative of the customer.
- (D) When law enforcement agencies are to be brought into the investigation, the authorized Security Representative of the customer shall secure their participation or authorize the Telephone Company in writing to obtain and coordinate such law enforcement agency participation.
- (E) When evidence collected by the Telephone Company is to be produced in connection with a judicial proceeding, the customer shall notify the Telephone company of such a requirement in a timely manner.
- (F) When the customer requests that service be suspended for unauthorized use, the customer shall furnish a written request authorized by an officer of the customer. The request shall state the reason for the request and tariff, contract or legal provision permitting such suspension and shall correctly identify the end user, the end user telephone number and the location of the end user service to be suspended.

Advice No. 03-28

Issued July 23, 2003

Effective August 23, 2003

Issued By CENTURYTEL OF WASHINGTON, INC. d/b/a CenturyTel
P.O. Box 9901, Vancouver, WA

(C)

By Pamela Donovan Title Supervisor, Tariffs

ACCESS SERVICE

8. Billing and Collection Services (Cont'd)

8.3 Billing Analysis Service (Cont'd)

8.3.4 Obligations of the Customer (Cont'd)

- (G) All inquiries from the customer's end user concerning services provided under this tariff are to be handled by the customer. Any questions to the Telephone Company shall be made by the authorized Security representative of the customer.
- (H) Except as set forth in 8.3.2(D)(4) preceding, publicizing of actions resulting from services provided under this tariff shall be the responsibility of the customer. The customer shall not publicize that the Telephone Company assisted the customer unless the customer has written permission to do so from the Telephone Company.
- (I) When the authorized Security representative of the customer orders detection service or a detection and documentation scan of an individual line, it shall specify in writing the offices, lines or parties to be included in the scanning and reports the Telephone Company will provide.
- (J) When provision of expert witness analysis is ordered by the customer, the customer shall be responsible for furnishing the evidence to be analyzed unless the services as set forth in 8.3.2(C)(10) preceding are ordered by the customer.
- (K) When provision of expert witness testimony is ordered by the customer, the customer shall include the name, if any, of the Telephone Company expert it desires and when and where the testimony is needed.
- (L)

8.3.5 Payment Arrangements

(A) Minimum Periods

The minimum period for which Billing Analysis detection service continuous scanning is provided and for which charges apply is one week.

Advice No. 03-28

Issued July 23, 2003

Effective August 23, 2003

Issued By CENTURYTEL OF WASHINGTON, INC. d/b/a CenturyTel
P.O. Box 9901, Vancouver, WA

(C)

By Pamela Donovan Title Supervisor, Tariffs

ACCESS SERVICE

8. Billing and Collection Services (Cont'd)

8.3 Billing Analysis Service (Cont'd)

8.3.6 Rate Regulations

- (A) The charge per report for the 60 day report, as set forth in Sections 16, 17 and 18 following, applies for each report provided to a customer even though no signaling irregularities are found.
- (B) The charge per office per week for continuous scan as set forth in Sections 16, 17 and 18 following applies for each week of service even though no signaling irregularities are found.
- (C) The per hour rate for investigative service and/or deterrence service is for the use of one hour of one Telephone Company Security person's time.
- (D) The Telephone Company will keep a count of the hours and fraction thereof used by Telephone Company personnel to provide the service the customer ordered and will bill the customer in accordance with these records. The hours for each service ordered will be summed and then rounded to the nearest hour, except that when the total is less than one hour, one hour will be used to determine charges.
- (E) Premium time is all hours for work performed outside the Telephone Company's normal work schedule and/or which required additions to the work force.
- (F) The Provision of Billing Analysis Service per Special Order charge applies for each Special Order accepted by the Telephone Company for any Billing Analysis Service.

Advice No. 03-28

Issued July 23, 2003

Effective August 23, 2003

Issued By CENTURYTEL OF WASHINGTON, INC. d/b/a CenturyTel
P.O. Box 9901, Vancouver, WA

(C)

By Pamela Donovan Title Supervisor, Tariffs

ACCESS SERVICE

8. Billing and Collection Services (Cont'd)

8.4 Billing Information Service

At the request of the customer, the Telephone Company will provide information to the customer from its end user records, billing files and account data base.

8.4.1 General Description

Billing Information Service is the provision of information to the customer from Telephone Company record systems labeled as Customer Records Information System (CRIS) and Non-Sent-Paid Indicator Data Base (DBAS). Such Billing Information Service will be limited to the provision of information to a customer relating exclusively to end user services provided by that customer. Information relating to services provided by any other entity will not be provided.

Information is defined as any entry in the records, data base or bureau listings which is not listed as proprietary to the Telephone Company. Any entry listed as proprietary to the Telephone Company will not be provided.

8.4.2 Undertaking of the Telephone Company

(A) When Billing Information Service is ordered by the customer, the Telephone Company will provide information on a request by request basis as follows in (B) through (M) following at the rates and charges as set forth in 8.4.7 following.

(B) Upon request from a customer and when the customer has ordered Message Billing Service Bill Processing Service, the Telephone Company will provide information from its CRIS records as follows:

- (1) message detail for a message end user
- (2) account detail for a message end user
- (3) service and equipment detail for a message end user.

Message detail is message-billed records in exchange message record (EMR) format in the CRIS file.

Advice No. 03-28

Issued July 23, 2003

Effective August 23, 2003

Issued By CENTURYTEL OF WASHINGTON, INC. d/b/a CenturyTel
P.O. Box 9901, Vancouver, WA

(C)

By Pamela Donovan Title Supervisor, Tariffs

ACCESS SERVICE

8. Billing and Collection Services (Cont'd)
8.4 Biling Information Service (Cont'd)
8.4.2 Undertaking of the Telephone Company (Cont'd)
(B) (Cont'd)

Account detail is data that furnishes the end user name, billing address and billing parameters other than message detail and/or service and equipment detail.

Service and equipment detail is data associated with the customer's rate elements.

A message end user is an account with customer message or bulk-billed detail (for a bill period) or an account which is marked, as set forth in (F) following, or established as an end user of the customer's message or bulk-billed services.

Message detail, account detail and/or service and equipment detail which is confidential due to legal, national security, end user or other appropriate requirements will not be provided. If the customer requires this information in order to bill its services, it shall secure written permission from the end user to obtain the information from the Telephone Company. The customer shall furnish the Telephone Company the end user's written permission for the information to be released.

Advice No. 03-28

Issued July 23, 2003

Effective August 23, 2003

Issued By CENTURYTEL OF WASHINGTON, INC. d/b/a CenturyTel
P.O. Box 9901, Vancouver, WA

(C)

By Pamela Donovan Title Supervisor, Tariffs

ACCESS SERVICE

8. Billing and Collection Services (Cont'd)

8.4 Biling Information Service (Cont'd)

8.4.2 Undertaking of the Telephone Company (Cont'd)

(C) Upon request from a customer and when the customer has ordered Private Line Billing Service, the Telephone company will provide information from its CRIS records as follows:

- (1) account detail for a private line end user
- (2) service and equipment detail for a private line end user.

Account detail is data that furnished the end user name, billing address and billing parameters other than message detail and/or service and equipment detail.

Service and equipment detail is data associated with the customer's rate elements.

A private line end user is an account with rate element detail (for a bill period) or an account which is established, at customer request, as an end user of the customer's private line (non-message) services.

Account detail and/or service and equipment detail which is confidential due to legal, national security, end user or other appropriate requirements will not be provided. If the customer requires this information in order to bill its services, it shall secure written permission from the end user to obtain the information from the Telephone Company. The customer shall furnish the Telephone Company the end user's written permission for the information to be released.

Advice No. 03-28

Issued July 23, 2003

Effective August 23, 2003

Issued By CENTURYTEL OF WASHINGTON, INC. d/b/a CenturyTel
P.O. Box 9901, Vancouver, WA

(C)

By Pamela Donovan Title Supervisor, Tariffs

ACCESS SERVICE

8. Billing and Collection Services (Cont'd)
8.4 Biling Information Service (Cont'd)
8.4.2 Undertaking of the Telephone Company (Cont'd)

(F) CRIS and/or DBAS information will be provided on a total file and/or file update basis as follows:

- (1) The total file basis will permit the customer to receive, at the customer's option, all the end user information that is authorized for the customer's use on paper printout, magnetic tape or fiche. The total file output will contain end user information for the current billing period. The billing period will be set by the Telephone Company. The magnetic tapes will be provided without the return of previously supplied tapes. The Telephone Company will supply the magnetic tapes. After he information system ordered by the customer is in service, the paper printout, magnetic tape or fiche will be available from the Telephone Company within 10 working days of the customer request.

Program development charges as set forth in Sections 16, 17 and 18 following apply for the hours required to design, develop, test and maintain the necessary programs that are used to provide the paper output, magnetic tape or fiche.

Once available, the paper printout magnetic tape or fiche will be sent to the customer via first class U.S. Mail service. At the option of the customer, the customer may pick up the paper printout, magnetic tape or fiche at a location designated by the Telephone Company.

Advice No. 03-28

Issued July 23, 2003

Effective August 23, 2003

Issued By CENTURYTEL OF WASHINGTON, INC. d/b/a CenturyTel
P.O. Box 9901, Vancouver, WA

(C)

By Pamela Donovan Title Supervisor, Tariffs

ACCESS SERVICE

8. Billing and Collection Services (Cont'd)
 8.4 Biling Information Service (Cont'd)
 8.4.2 Undertaking of the Telephone Company (Cont'd)
 (F) (Cont'd)

- (2) The file update basis will permit the customer to receive, at the customer option, all the end user information that is authorized for the customer's use on paper printout, fiche or magnetic tape. The file update output will contain end user information for the current billing period only. The current billing period is the period associated with the most recent bill rendered to an end user. The magnetic tapes will be provided without the return of previously supplied tapes. The Telephone Company will supply magnetic tapes. The file updates will include those records added and those records deleted, if any. For CRIS information, the file updates will be provided on a monthly interval. For DBAS information, the file updates will be provided for each business day.

Program development charges as set forth in Sections 16, 17 and 18 following,

apply for the hours required to design, develop, test and maintain the necessary programs that are used to provide the paper output, fiche or magnetic tape.

Once available, the file update paper printout, fiche or magnetic tape will be sent to the customer via first class U.S. Mail service. At the option of the customer, the customer may pick up the paper output, fiche or magnetic tape at a location designated by the Telephone Company.

- (3) The total file output and the file update output will, at the option of the customer, be provided on a quick turnaround basis. Such quick turnaround output will be provided one working day after the information that the customer ordered is available. Once available, the output will be provided on paper printout, fiche, or magnetic tape and will be sent to the customer via first class U.S. Mail service. At the option of the customer, the customer may pick up the paper output, fiche or magnetic tape at a location designated by the Telephone Company.

Advice No. 03-28

Issued July 23, 2003

Effective August 23, 2003

Issued By CENTURYTEL OF WASHINGTON, INC. d/b/a CenturyTel
 P.O. Box 9901, Vancouver, WA

(C)

By Pamela Donovan Title Supervisor, Tariffs

ACCESS SERVICE

8. Billing and Collection Services (Cont'd)

8.4 Biling Information Service (Cont'd)

8.4.2 Undertaking of the Telephone Company (Cont'd)

- (G) The Telephone Company will, at the request of the customer, mark any message-billed message end user account, other than end user accounts with customer credit cards or rate elements, as a user of the customer's message services. After marking is ordered, the end user account will be marked as a customer end user account at the time the first message is posted to the end user account. If not marked at the request of the customer, such an end user account will not be identified as a customer account unless there are customer message details associated with the account for the bill period for which message detail is ordered by the customer. The mark will be removed at the request of the customer. Charges to mark the account and maintain the mark in future months as set forth in Sections 16, 17 and 18 following apply. Customer bulk-billed end user accounts and message end user accounts with customer credit cards or customer rate elements are counted as customer accounts.
- (H) Upon acceptance by the Telephone Company of a Special Order for Billing Information Service from a customer, the Telephone Company will determine the period of time to implement such service on an individual order basis.
- (I) The Telephone Company will provide the format for interrogation of its data files and the format of any printed, magnetic tape or fiche output from its CRIS and DBAS files.
- (J) Upon request from an authorized supervisor of the customer who furnished the account code assigned by the Telephone Company, the Telephone Company will provide name and town information. Name and town data, but no street address, will be provided only when the customer needs the information to authorize a call, to bill a call, or to handle an emergency situation. The information will be provided on a request by request basis by voice telecommunications. Name, town and state will be provided for a telephone number. A request includes the handling of one call and providing the data for one telephone number.

Advice No. 03-28

Issued July 23, 2003

Effective August 23, 2003

Issued By CENTURYTEL OF WASHINGTON, INC. d/b/a CenturyTel
P.O. Box 9901, Vancouver, WA

By Pamela Donovan

Title Supervisor, Tariffs

(C)

ACCESS SERVICE

8. Billing and Collection Services (Cont'd)

8.4 Biling Information Service (Cont'd)

8.4.4 Obligations of the Customer

- (A) The customer shall order Billing Information Service under a Special Order. The customer shall order those Billing Information Services for the states where it wishes to receive the services and shall specify how often it wishes the service to be provided.
- (B) With each order, the customer shall identify the authorized individual and address to receive the Billing Information Service output. When interrogation is ordered, the customer shall identify the data processing terminals authorized to receive the information and the authorized individual who will be responsible for all terminal activities. When Billing Information Service is ordered, the customer will identify in writing and include the account codes assigned by the Telephone Company of all authorized individuals who will contact the Telephone Company.
- (C) The customer shall take every effort to make sure that Billing Information Service output and interrogation capability is provided only to authorized personnel. The customer shall agree, in writing to the Telephone Company, that the customer will not provide the Billing Information Service outputs to third parties for any use by such third parties except for work for the customer and which is under complete control of the customer.
- (D) The customer shall furnish, to the Telephone Company, when interrogation service is ordered all information necessary to allow the Telephone Company to establish an interrogation program. In addition, the customer shall furnish the Telephone Company, for each data base and file where the interrogation is ordered, an estimate of the number of requests per business day that the Telephone Company data bases and file will be asked to handle. The customer's terminals used to interrogate the Telephone Company data bases and files must be capable of working with Telephone Company equipment and software.

Advice No. 03-28

Issued July 23, 2003

Effective August 23, 2003

Issued By CENTURYTEL OF WASHINGTON, INC. d/b/a CenturyTel
P.O. Box 9901, Vancouver, WA

(C)

By Pamela Donovan Title Supervisor, Tariffs

ACCESS SERVICE

8. Billing and Collection Services (Cont'd)

8.4 Biling Information Service (Cont'd)

8.4.4 Obligations of the Customer (Cont'd)

- (E) The customer shall be responsible for all contacts and inquiries from its end users concerning Billing Information Service.
- (F) The customer shall not publicize or represent to others that the Telephone Company jointly participates with the customer in the development of the customer's end user records, accounts, data bases or market data, records, files and data bases or other systems it assembles through the use of Billing Information Service.
- (G) When the customer orders marking of non customer credit card message-billed message end user accounts, all accounts containing that customer's messages will be marked starting with the next bill period and marking will continue until the customer orders marking discontinued. The customer shall, when it orders marking removed, furnish the telephone number of each end user account for which the mark is to be removed. The mark will be removed prior to the next bill period.

Advice No. 03-28

Issued July 23, 2003

Effective August 23, 2003

Issued By CENTURYTEL OF WASHINGTON, INC. d/b/a CenturyTel
P.O. Box 9901, Vancouver, WA

(C)

By Pamela Donovan Title Supervisor, Tariffs

ACCESS SERVICE

8. Billing and Collection Services (Cont'd)

8.4 Biling Information Service (Cont'd)

8.4.5 Payment Arrangements

(A) Minimum Periods and Minimum Monthly Charges

The minimum period for which Billing Information Service CRIS and/or DBAS file interrogation is provided and for which charges apply is one year.

The minimum monthly charges for CRIS and/or DBAS file interrogation are the charges for the total number of requests per business day furnished by the customer as set forth in 8.4.4(D) preceding times 18 (i.e., 20 business days per month times 0.9).

When the customer discontinues the service prior to the end of the one-year minimum period, the minimum monthly charge for the data base interrogation will apply for each remaining month and fraction of month.

(B) Cancellation of a Special Order

A customer may cancel a Special Order for Billing Information Service on any date prior to the service date. The cancellation date is the date the Telephone Company receives written or verbal notice from the customer that the Special Order is to be cancelled. The verbal notice must be followed by written confirmation within 10 days. The service date for a Billing Information Service is the date the Telephone Company notifies the customer that the Telephone Company is ready to provide Billing Information Service reports or receive interrogation requests.

Advice No. 03-28

Issued July 23, 2003

Effective August 23, 2003

Issued By CENTURYTEL OF WASHINGTON, INC. d/b/a CenturyTel
P.O. Box 9901, Vancouver, WA

(C)

By Pamela Donovan Title Supervisor, Tariffs

ACCESS SERVICE

8. Billing and Collection Services (Cont'd)

8.4 Biling Information Service (Cont'd)

8.4.5 Payment Arrangements (Cont'd)

(B) Cancellation of a Special Order (Cont'd)

When a customer cancels a Special Order for Billing Information Service after the order date but prior to the start of service, charges as listed following shall apply:

- (1) For any service, the appropriate per hour rate for all hours expended by the Telephone Company to provide the service.
- (2) For any service, any expense for equipment obtained for the service where such equipment cannot be reused within six months.

(C) Changes to Special Orders

When a customer requests changes for a pending Special Order for Billing Information Service, they will be undertaken if they can be accommodated by the Telephone Company. Any additional time required on the part of Telephone Company personnel will be billed to the customer at the appropriate hourly charges.

8.4.6 Rate Regulations

- (A) The number and type of records for which charges apply as set forth in Sections 16, 17

and 18 following will be accumulated by the Telephone Company and the Telephone

Company will bill the customer in accordance with these accumulations. A record is a logical grouping of information as described in the programs that process the information, print the paper output, and load the magnetic tape or data file used to supply the detail which is put on fiche. For each service and type of output ordered, the number of records processed by the Telephone Company to prepare the output will be used to determine the charges. The number of records processed will be determined using the number of records input to or the number of records output from the programs that process the information, print the paper output and load the magnetic tape or data file, whichever number of records is higher.

Advice No. 03-28

Issued July 23, 2003

Effective August 23, 2003

Issued By CENTURYTEL OF WASHINGTON, INC. d/b/a CenturyTel
P.O. Box 9901, Vancouver, WA

(C)

By Pamela Donovan Title Supervisor, Tariffs

ACCESS SERVICE

8. Billing and Collection Services (Cont'd)

8.4 Biling Information Service (Cont'd)

8.4.6 Rate Regulations (Cont'd)

- (B) The number of hours and fraction thereof for which charges apply as set forth in Sections 16, 17 and 18 following will be accumulated by the Telephone Company. The per hour rate is for the use of one hour of one Telephone Company programmer. The Telephone Company will bill the customer for hourly charges in accordance with these accumulations. The accumulated hours for each order will be summed and rounded to the nearest hour, except that when the total is less than one hour, one hour will be used to determine the charges.
- (C) When a customer name and address request is received, the Telephone Company will keep a count of the requests. The Telephone Company will bill the customer in accordance with these records even though the Telephone Company was not able to provide a name and town location for all requests.
- (D) When records are entered on a data file or magnetic tape in order to provide information to a customer, the per tape charge applies for each data file or tape prepared. In addition, the per record charge applies for each record entered on the data file or tape. The Telephone Company will determine the charges based on the number of data files or tapes prepared and on its count of the records entered on the data file or tape.
- (E) When marking of message end user accounts is ordered, the marking charge applies for each end user account marked. Once an account is marked, the maintenance of mark charge applies for each month following the month the account is marked until the customer requests the mark be removed. No charges apply to remove the mark.
- (F) The Provision of Billing Information Service per Special Order Charge applies for each Special Order accepted by the Telephone Company for any Billing Information Service.

Advice No. 03-28

Issued July 23, 2003

Effective August 23, 2003

Issued By CENTURYTEL OF WASHINGTON, INC. d/b/a CenturyTel
P.O. Box 9901, Vancouver, WA

(C)

By Pamela Donovan Title Supervisor, Tariffs

WN U-4

Second Revised Sheet No. 321
Cancels
First Revised Sheet No. 321
CENTURYTEL OF WASHINGTON, INC.

(C)

ACCESS SERVICE

8. Billing and Collection Services (Cont'd)
8.4 Biling Information Service (Cont'd)

Advice No. 03-28

Issued July 23, 2003 Effective August 23, 2003
Issued By CENTURYTEL OF WASHINGTON, INC. d/b/a CenturyTel
 P.O. Box 9901, Vancouver, WA
By Pamela Donovan Title Supervisor, Tariffs

(C)

WN U-4

Second Revised Sheet No. 322
Cancels
First Revised Sheet No. 322
CENTURYTEL OF WASHINGTON, INC.

(C)

ACCESS SERVICE

- 8. Billing and Collection Services (Cont'd)
- 8.4 Biling Information Service (Cont'd)

Advice No. 03-28

Issued July 23, 2003 Effective August 23, 2003
Issued By CENTURYTEL OF WASHINGTON, INC. d/b/a CenturyTel
 P.O. Box 9901, Vancouver, WA
By Pamela Donovan Title Supervisor, Tariffs

(C)

WN U-4

Second Revised Sheet No. 323
Cancels
First Revised Sheet No. 323
CENTURYTEL OF WASHINGTON, INC.

(C)

ACCESS SERVICE

8. Billing and Collection Services (Cont'd)
8.4 Biling Information Service (Cont'd)

Advice No. 03-28

Issued July 23, 2003 Effective August 23, 2003
Issued By CENTURYTEL OF WASHINGTON, INC. d/b/a CenturyTel
 P.O. Box 9901, Vancouver, WA
By Pamela Donovan Title Supervisor, Tariffs

(C)

WN U-4

First Revised Sheet No. 324
Cancels
Original Sheet No. 324
CENTURYTEL OF WASHINGTON, INC.

(C)

ACCESS SERVICE

9.

Advice No. 03-28

Issued July 23, 2003

Effective August 23, 2003

Issued By CENTURYTEL OF WASHINGTON, INC. d/b/a CenturyTel
P.O. Box 9901, Vancouver, WA

(C)

By Pamela Donovan Title Supervisor, Tariffs

ACCESS SERVICE

10. Special Federal Government Access Services

10.1 General

This section covers Special Access Services that are provided to a customer for use only by agencies or branches of the Federal Government and other users authorized by the Federal Government. Services provided to state emergency operations centers are included. These services provide for command and control communications, including communications for national security, emergency preparedness and presidential requirements. They are required to assure continuity of Government in emergency and crisis situations and to provide for national security.

Services for command and control communications and for national security and emergency preparedness sometimes require short notice and short duration service provisions. These provisions are especially needed to meet presidential requirements or in response to natural, man-made, or declared emergencies. Requirements of this type cannot be forecasted and are usually needed for a relatively short period. The provision of service under these conditions may require the availability of facilities, such as portable microwave equipment, which are provided on a temporary basis by the Telephone Company or customer.

10.2 Emergency Conditions

These services will be provided on the date requested or as soon as possible thereafter when the emergency falls into one of the following categories:

State of crisis declared by the National Command Authorities (includes commitments made to the National Communications System in the "National Plan for Emergencies and Major Disasters").

Advice No. 03-28

Issued July 23, 2003

Effective August 23, 2003

Issued By CENTURYTEL OF WASHINGTON, INC. d/b/a CenturyTel
P.O. Box 9901, Vancouver, WA

(C)

By Pamela Donovan Title Supervisor, Tariffs

ACCESS SERVICE

10. Special Federal Government Access Services (Cont'd)

10.2 Emergency Conditions (Cont'd)

Efforts to protect endangered U.S. personnel or property both in the U.S. and abroad. (Includes space vehicle recovery and protection efforts.)

Communications requirements resulting from hostile action, a major disaster or a major civic disturbance.

The director (Cabinet level) of a Federal department, Commander of a Unified/Specified command, or head of a military department has certified that a communications requirement is so critical to the protection of life and property or to the National Defense that it must be processed immediately.

Political unrest in foreign countries which affect the national interest.

Presidential service.

10.3 Intervals to Provide Service

Services provided under the provisions of this section of the tariff are provided on an individual case basis. Therefore, orders for such service shall be placed under the Negotiated Interval provision set forth in 5.2.1(B) preceding.

10.4

Advice No. 03-28

Issued July 23, 2003

Effective August 23, 2003

Issued By CENTURYTEL OF WASHINGTON, INC. d/b/a CenturyTel
P.O. Box 9901, Vancouver, WA

(C)

By Pamela Donovan Title Supervisor, Tariffs

ACCESS SERVICE

10. Special Federal Government Access Services (Cont'd)

10.5 Safeguarding of Service

10.5.1

10.5.2 Facility Availability

In order to insure communications during periods of emergency, the Telephone Company will, within the limits of good management, make available the necessary facilities to restore service in the event of damage or to provide temporary emergency service. In order to meet the requirements of agencies or branches of the Federal Government, the Telephone Company may utilize government-owned facilities, when necessary to provide service.

10.6 Federal Government Regulations

In accordance with Federal Government Regulations, all service provided to the Federal Government as a customer will be billed in arrears. However, this provision does not apply to other customers that obtain services under the provision of this tariff to provide their services to the Federal Government.

10.7

Advice No. 03-28

Issued July 23, 2003

Effective August 23, 2003

Issued By CENTURYTEL OF WASHINGTON, INC. d/b/a CenturyTel
P.O. Box 9901, Vancouver, WA

(C)

By Pamela Donovan Title Supervisor, Tariffs

ACCESS SERVICE

10.. Specialized Federal Government Access Services (Cont'd)

10.8 Service Offerings to the Federal Government

The following services, are provided to a customer only for agencies or branches of the Federal Government, other authorized users and state emergency operations centers. The rates and charges for these services shall be developed on an individual case basis and shall be consistent with the rates and charges for services offered in other sections of this tariff.

10.8.1 Type and Description

(A) Voice Grade Special Access Services

(1) Voice Grade Secure Communications Type I

Approximate bandwidth of 10-50,000 Hertz, Furnished for two-point secure communications on two-wire or four-wire metallic facilities between a customer premises and another customer's premises. Services are conditioned as follows:

T-3 Conditioning - The absolute loss (referenced to 1 milliwatt) with respect to frequency shall not exceed:

15 dB at 10 Hz
13 dB at 100 Hz
9 dB at 1,000 Hz
20 dB at 10,000 Hz
30 dB at 50,000 Hz

Advice No. 03-28

Issued July 23, 2003

Effective August 23, 2003

Issued By CENTURYTEL OF WASHINGTON, INC. d/b/a CenturyTel
P.O. Box 9901, Vancouver, WA

(C)

By Pamela Donovan Title Supervisor, Tariffs

ACCESS SERVICE

10. Special Federal Government Access Services (Cont'd)
10.8 Service Offerings to the Federal Government (Cont'd)
10.8.1 Type and Description (Cont'd)
(A) Voice Grade Special Access Services (Cont'd)
(1) Voice Grade Secure Communications Type I (Cont'd)

Additional conditioning (available in one or two directions on four-wire facilities only) to provide the following characteristics:

The absolute loss (referenced to one milliwatt) with respect to frequency shall not exceed:

- 0 dB at 1,000 Hz
 - ± 1 dB between 1,000 Hz and 40,000 Hz
 - ± 2 dB between 10 Hz and 50,000 Hz
- (+ means more loss)

The net loss of the conditioned service (with or without additional conditioning) shall not vary by more than four dB at 1,000 Hz from the levels specified above. Voice frequency signaling or supervisory tones can be transmitted.

- (2) Voice Grade Secure Communications Type II

Approximate bandwidth 10-50,000 Hz. Furnished on four-wire metallic facilities for duplex operation for two-point secure communication between a customer terminal on a customer's premises and another customer's premises. Services are conditioned as follows:

G-1 Conditioning - The absolute loss with respect to frequency and the net loss variation shall be the same as Voice Grade Secure Communications Type I services without additional conditioning. Voice frequency signaling or supervisory tones can be transmitted.

Advice No. 03-28

Issued July 23, 2003

Effective August 23, 2003

Issued By CENTURYTEL OF WASHINGTON, INC. d/b/a CenturyTel
P.O. Box 9901, Vancouver, WA

(C)

By Pamela Donovan Title Supervisor, Tariffs

ACCESS SERVICE

10. Special Federal Government Access Services (Cont'd)
10.8 Service Offerings to the Federal Government (Cont'd)
10.8.1 Type and Description (Cont'd)
(A) Voice Grade Special Access Services (Cont'd)
(3) Voice Grade Secure Communications Type III

Approximate bandwidth 10-50,000 Hz. Furnished on four-wire metallic facilities for duplex operation for two-point secure communication between a premises switch and a customer's premises. Services are conditioned as follows:

G-2 Conditioning - The absolute loss with respect to frequency and the net loss variation from the switch to an end user's premises shall be the same as Voice Grade Secure Communications Type I services without additional conditioning; from an end user's premises to the switch shall be the same as Voice Grade Secure Communications Type I services with additional conditioning. Voice frequency signaling or supervisory tones can be transmitted.

- (4) Voice Grade Secure Communications Type IV

Approximate bandwidth 10-50,000 Hz. Furnished on four-wire metallic facilities for duplex operation for two-point secure communication between two premises switches. Services are conditioned as follows:

G-3 Conditioning - The absolute loss with respect to frequency and the net loss variation shall be the same in both directions of transmission as Voice Grade Secure Communications Type I services with additional conditioning. Voice frequency signaling or supervisory tones can be transmitted.

Advice No. 03-28

Issued July 23, 2003

Effective August 23, 2003

Issued By CENTURYTEL OF WASHINGTON, INC. d/b/a CenturyTel
P.O. Box 9901, Vancouver, WA

(C)

By Pamela Donovan Title Supervisor, Tariffs

ACCESS SERVICE

10. Special Federal Government Access Services (Cont'd)
10.8 Service Offerings to the Federal Government (Cont'd)
10.8.1 Type and Description (Cont'd)
(B) Wideband Digital Special Access Service

Service arrangements for secured communications to accommodate the transmission of binary digital baseband signals in a random polar format.

- (1) Wideband Secure Communications Type I

For transmissions at the rate of 18,750 bits per second.

- (2) Wideband Secure Communications Type II

For transmission at the rate of 50,000 bits per second.

- (3) Wideband Secure Communications Type III

To accommodate the transmission of restored polar two-level facsimile signals with a minimum signal element width of twenty microseconds at a rate of 50,000 bits per second.

To accommodate the transmission of binary digital baseband signals in a random polar format at the rate of 50,000 bits per second.

10.8.2 Mileage Application

Mileage, when used for rate application between two customer designated premises, shall be determined by the V and H Coordinates Method as set forth in EXCHANGE CARRIER ASSOCIATION TARIFF.C.C. No. 4.

Advice No. 03-28

Issued July 23, 2003

Effective August 23, 2003

Issued By CENTURYTEL OF WASHINGTON, INC. d/b/a CenturyTel
P.O. Box 9901, Vancouver, WA

(C)

By Pamela Donovan Title Supervisor, Tariffs

WN U-4

Second Revised Sheet No. 332
Cancels
First Revised Sheet No. 332
CENTURYTEL OF WASHINGTON, INC.

(C)

ACCESS SERVICE

10. Special Federal Government Access Services (Cont'd)
10.8 Service Offerings to the Federal Government (Cont'd)

Advice No. 03-28

Issued July 23, 2003 Effective August 23, 2003
Issued By CENTURYTEL OF WASHINGTON, INC. d/b/a CenturyTel
 P.O. Box 9901, Vancouver, WA
By Pamela Donovan Title Supervisor, Tariffs

(C)

ACCESS SERVICE

10. Special Federal Government Access Services (Cont'd)
10.8 Service Offerings to the Federal Government (Cont'd)
10.8.3 Rates and Charges (Cont'd)
(C) Move Charges (Cont'd)

- (2) When service with a termination charge associated with it, as set forth in (A) and (B) preceding, is moved and is reinstalled at a new location, the customer may elect:

to pay the unexpired portion of the termination charge for the service, if any, with the application of a nonrecurring charge and the establishment of a new termination charge for such service at the new location, or

to continue service subject to the unexpired portion of the termination charge, if any, and pay the estimated costs of moving such service, provided that the customer requests these charges be quoted prior to ordering the service move. Charges for moving such service will be based on estimated costs attributable to the move.

Move charges include the estimated costs of removal, restoration of services or facilities necessitated by the move, transportation, storage, reinstallation, engineering, labor, supervision, materials, administration, and any other specific items of cost directly attributable to the move.

Advice No. 03-28

Issued July 23, 2003

Effective August 23, 2003

Issued By CENTURYTEL OF WASHINGTON, INC. d/b/a CenturyTel
P.O. Box 9901, Vancouver, WA

(C)

By Pamela Donovan Title Supervisor, Tariffs

ACCESS SERVICE

11. Special Facilities Routing of Access Services
11.1 Description of Special Facilities Routing of Access Services

The services provided under this tariff are provided over such routes and facilities as the Telephone Company may elect. Special Facilities Routing is involved, when, in order to comply with requirements specified by the customer, the Telephone Company provides Switched Access Service, Special Access Service or Special Federal Government Access Service in a manner which includes one or more of the following conditions:

11.1.1 Diversity

Two or more services must be provided over not more than two different physical routes.

11.1.2 Avoidance

A service must be provided on a route which avoids specified geographical locations.

11.1.3 Cable-Only Facilities

Certain Voice Grade services are provided on Cable-Only Facilities to meet the particular needs of an customer.

Service is provided subject to the availability of Cable-Only facilities. In the event of service failure, restoration will be made through the use of any available facilities as selected by the Telephone Company.

Avoidance and Diversity are available on Switched Access Service as set forth in 6. preceding; Narrowband, Voice Grade and Wideband Analog Special Access Services as set forth in 7.2.1, 7.2.2 and 7.2.5 preceding and Special Federal Government Access Services as set forth in 10.8 preceding. Cable-Only Facilities are available for Switched Access Service as set forth in 6. preceding; Voice Grade Special Access Services as set forth in 7.2.2 preceding and Special Federal Government Access Services as set forth in 10.8 preceding.

Advice No. 03-28

Issued July 23, 2003

Effective August 23, 2003

Issued By CENTURYTEL OF WASHINGTON, INC. d/b/a CenturyTel
P.O. Box 9901, Vancouver, WA

(C)

By Pamela Donovan Title Supervisor, Tariffs

WN U-4

Second Revised Sheet No. 337
Cancels
First Revised Sheet No. 337
CENTURYTEL OF WASHINGTON, INC.

(C)

ACCESS SERVICE

11. Special Facilities Routing of Access Services (Cont'd)

Advice No. 03-28

Issued July 23, 2003 Effective August 23, 2003
Issued By CENTURYTEL OF WASHINGTON, INC. d/b/a CenturyTel
 P.O. Box 9901, Vancouver, WA
By Pamela Donovan Title Supervisor, Tariffs

(C)

ACCESS SERVICE

12. Specialized Service Or Arrangements

Specialized Service or Arrangements may be provided by the Telephone Company, at the request of a customer on an individual case basis if such service or arrangements meet the following criteria:

The requested service or arrangements are not offered under other sections of this tariff.

The facilities utilized to provide the requested service or arrangements are of a type normally used by the Telephone Company in furnishing its other services.

The requested service or arrangements are provided within a LATA.

The requested service or arrangements are compatible with other Telephone Company services, facilities, and its engineering and maintenance practices.

This offering is subject to the availability of the necessary Telephone Company personnel and capital resources.

Rates, charges and/or additional regulations, if applicable, for specialized service or arrangements provided on an individual case basis are filed in Sections 16, 17 and 18 following.

Advice No. 03-28

Issued July 23, 2003

Effective August 23, 2003

Issued By CENTURYTEL OF WASHINGTON, INC. d/b/a CenturyTel
P.O. Box 9901, Vancouver, WA

(C)

By Pamela Donovan Title Supervisor, Tariffs

ACCESS SERVICE

12. SPECIALIZED SERVICE OR ARRANGEMENTS (Cont'd)12.2 Ethernet Service

(N)

12.2.1 General

Ethernet Service is a high speed data transport service that provides end-to-end transmission using Ethernet packet technology at transport speeds ranging from 1 Megabit per second (Mbps) to 1 Gigabit per second (Gbps), where available. Ethernet is ideal for transport of broadband multimedia traffic (i.e., voice, data and video) using variable length Ethernet packets with the ability to interconnect multiple locations using the Telephone Company's Ethernet network. Ethernet packets are transmitted using capacity on dedicated and shared transmission paths through the Telephone Company's Ethernet network to a pre-specified destination.

Customers may use Ethernet to:

- a. Interconnect customer designated premises (CDPs) served by the Telephone Company's Ethernet network,
- b. Interconnect with their local area network (LAN) to the Telephone Company's Ethernet network and/or
- c. Interconnect their CDPs to an Ethernet network located outside of the Telephone Company's serving territory.

(N)

Advice No. 08-05 Supplement A

Issued February 27, 2008

Effective March 23, 2008

Issued By CENTURYTEL OF WASHINGTON, INC. d/b/a CenturyTel
P.O. Box 9901, Vancouver, WA

By Chantel Mosby Title Manager, Tariffs and Compliance

ACCESS SERVICE

12. SPECIALIZED SERVICE OR ARRANGEMENTS (Cont'd)

12.2 Ethernet Service

(N)

12.2.2. Service Description

Ethernet Service is provided using a combination of Ethernet Channel Terminations, Ethernet Basic Ports and Ethernet Interoffice Transport. As described below, Ethernet Service may also be used in conjunction with Special Access High Capacity circuits, Synchronous Optical Channel Service and/or with DSL Access Services.

An Ethernet Basic Port is required to provide the interface into the Telephone Company's Ethernet network. Ethernet Interoffice Transport establishes a shared transmission path between any two Ethernet Basic Ports on the Telephone Company's Ethernet network. Ethernet Interoffice Transport can also provide a shared transmission path to connect to another telephone companies Ethernet network.

The transmission quality of Ethernet is not guaranteed and is offered to Ethernet customers at a best effort level. The Telephone Company will attempt to deliver all Ethernet packets received; however, network congestion may result in a loss of Ethernet packets.

Transmission speeds may be affected by distance from the Telephone Company central office and other technical limitations in the Telephone Company's network and are also not guaranteed.

For multipoint Ethernet connections requiring the use of Ethernet Interoffice Transport, customers must designate a Telephone Company's SWC (Serving Wire Center) as the hub connection point. Once designated, the hub connection point becomes the location from which mileage is calculated to connect to all other Telephone Company's SWCs.

Ethernet service is provided, where available, between CDPs and designated Telephone Company (SWCs). Ethernet Service will be furnished where suitable facilities exist as determined by the Telephone Company. In locations where Ethernet service is not available, special construction charges may apply.

The application of rates and charges for Ethernet Service is described in A.5 of this section.

(N)

Advice No. 08-05

Issued February 22, 2008

Effective March 23, 2008

Issued By CENTURYTEL OF WASHINGTON, INC. d/b/a CenturyTel
P.O. Box 9901, Vancouver, WA

By Chantel Mosby Title Manager, Tariffs and Compliance

ACCESS SERVICE

12. SPECIALIZED SERVICE OR ARRANGEMENTS (Cont'd)

12.2 Ethernet Service (Cont'd)

(N)

12.2.5. Rate Categories

The various Ethernet Service elements are described below.

A. Ethernet Channel Terminations (CTs)

An Ethernet CT provides the transport facility between the customers designated premise and an Ethernet Basic Port at the Telephone Company's SWC. Also included in the Ethernet CT is the service delivery equipment required to provide Ethernet services.

Ethernet CTs are available at bandwidth speeds of 1 - 3 Mbps, 4 - 6 Mbps, 7 - 10 Mbps, 11 - 20 Mbps, 21 - 50 Mbps, 51 - 100 Mbps, 101 - 200 Mbps, 201 - 500 Mbps, and 501 Mbps - 1 Gbps. The customer orders an Ethernet CT based on bandwidth requirements. Bandwidth speeds of 50 Mbps and above require use of a fiber loop facility, where such fiber facilities exist. Ethernet CTs are available only from suitably equipped Telephone Company's SWCs for connection to Ethernet Basic Ports. Service delivery equipment will be provided and provisioned with up to four 10/100 Mbps customer interface ports, in which different Virtual Local Area Networks (VLAN's) associated with a particular site, can be delivered on separate ports. Additional charges will apply for VLAN's in excess of four that requires additional or higher capacity service delivery equipment than would ordinarily be needed for the bandwidth of the CT ordered. See rates section for additional customer interface port charges.

Monthly and nonrecurring charges apply for each Ethernet CT ordered. The monthly rate is based upon the bandwidth capacity requested.

(N)

Advice No. 08-05

Issued February 22, 2008

Effective March 23, 2008

Issued By CENTURYTEL OF WASHINGTON, INC. d/b/a CenturyTel
P.O. Box 9901, Vancouver, WA

By Chantel Mosby Title Manager, Tariffs and Compliance

ACCESS SERVICE

12. SPECIALIZED SERVICE OR ARRANGEMENTS (Cont'd)

12.2 Ethernet Service (Cont'd)

12.2.5. Rate Categories (Cont'd)

B. Ethernet Basic Port

Ethernet Basic Ports provide the interface at the Telephone Company's SWC for data traffic to and from the customer premise as well as for connecting the Telephone Company's Ethernet network with the Ethernet network of another telephone company. An Ethernet Basic Port receives Ethernet packets, validates the addressing parameters contained in the packet headers, and transmits the packets into the Ethernet network. The Ethernet Basic Port also receives Ethernet packets from the Telephone Company's Ethernet network or from an Ethernet network located outside of the Telephone Company's serving territory, validates the addressing parameters contained in the packet headers, and transmits the packets to the pre-designated CDP.

Ethernet Basic Ports provide the interface to the Telephone Company's Ethernet network and do not include the required transport facility between the CDP and the Telephone Company's SWC. Ethernet Basic Ports are available with bandwidth speeds of 1-3 Mbps, 4 - 6 Mbps, 7 - 10 Mbps, 11 - 20 Mbps, 21 - 50 Mbps, 51 - 100 Mbps, 101 - 200 Mbps, 201- 500 Mbps, and 501 Mbps - 1 Gbps.

Required transport to the Ethernet Basic Port is provided using an Ethernet CT as described above. In order to provision Ethernet Service, each Ethernet Basic Port must be assigned a minimum of one Ethernet VLAN. An Ethernet Basic Port may be associated with more than one Ethernet VLAN. The bandwidth speed of an Ethernet Basic Port must be equal to or greater than the bandwidth speed of the associated Ethernet CT and the aggregate sum of the VLANs.

(N)

(N)

Advice No. 08-05

Issued February 22, 2008

Effective March 23, 2008

Issued By CENTURYTEL OF WASHINGTON, INC. d/b/a CenturyTel
P.O. Box 9901, Vancouver, WA

By Chantel Mosby Title Manager, Tariffs and Compliance

ACCESS SERVICE

12. SPECIALIZED SERVICE OR ARRANGEMENTS (Cont'd)

12.2 Ethernet Service (Cont'd)

(N)

12.2.5. Rate Categories (Cont'd)

C. Ethernet Interoffice Transport

Ethernet VLANs are logical associations established by the Telephone Company across a shared transmission path that allow the customer to transmit packets between any two or more Ethernet Basic Ports located on the Telephone Company's Ethernet network and/or a connecting Telephone Company's Ethernet network. For multi-point VLANs, customers must designate a Telephone Company's SWC as the single hub connection point. The single hub connection point becomes the location from which mileage is calculated to connect to all other Telephone Company SWCs. The Ethernet Interoffice Transport bandwidth required is the sum of all VLAN speeds that traverse a particular point to point segment of the Telephone Company's Network. The costs of providing these logical transmission paths that extend beyond and between the Telephone Company's SWC are recovered through the billing element Ethernet Interoffice Transport. The Telephone Company will establish the Ethernet transmission paths necessary to provide the bandwidth capacity specified by the customer on its Access Order. Ethernet Interoffice Transport is available on a per mile basis in bandwidth speeds of 1 - 3 Mbps, 4 - 6 Mbps, 7 - 10 Mbps, 11 - 20 Mbps, 21 - 50 Mbps, 51 - 100 Mbps, 101 - 200 Mbps, 201 - 500 Mbps and 501 Mbps - 1 Gbps. Bandwidth speeds can be provisioned in 1 Mbps increments.

Monthly recurring charges apply for Ethernet Interoffice Transport. The monthly recurring charge is based upon the bandwidth capacity and the distance in miles of the Telephone Company's transmission path. The mileage charge will be based on airline miles between the Telephone Company's SWC and/or meet points. Fractions of miles will be considered as a whole mile.

(N)

Advice No. 08-05

Issued February 22, 2008

Effective March 23, 2008

Issued By CENTURYTEL OF WASHINGTON, INC. d/b/a CenturyTel
P.O. Box 9901, Vancouver, WA

By Chantel Mosby Title Manager, Tariffs and Compliance

ACCESS SERVICE

12. SPECIALIZED SERVICE OR ARRANGEMENTS (Cont'd)

12.2 Ethernet Service (Cont'd)

12.2.6. Application of Rates

The following diagrams illustratively show how the Ethernet rate elements are intended to apply to customer orders.

DIAGRAM/EXAMPLE 1

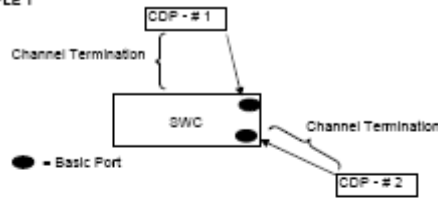

Customer orders 2 connections within the same SWC. Customer will be billed 2 Channel Terminations and 2 Basic Ports.

DIAGRAM/EXAMPLE 2

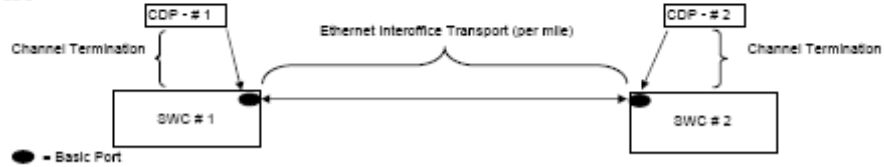

Customer orders 2 connections in different SWC. Customer will be billed 2 Channel Terminations, 2 Basic Ports and Ethernet Interoffice Transport between SWC # 1 and SWC # 2 based on mileage and bandwidth.

(N)

(N)

Advice No. 08-05

Issued February 22, 2008

Effective March 23, 2008

Issued By CENTURYTEL OF WASHINGTON, INC. d/b/a CenturyTel
P.O. Box 9901, Vancouver, WA

By Chantel Mosby Title Manager, Tariffs and Compliance

ACCESS SERVICE

12. SPECIALIZED SERVICE OR ARRANGEMENTS (Cont'd)

12.2 Ethernet Service (Cont'd)

12.2.6. Application of Rates (Cont'd)

The following diagrams illustratively show how the Ethernet rate elements are intended to apply to customer orders.

DIAGRAM/EXAMPLE 3

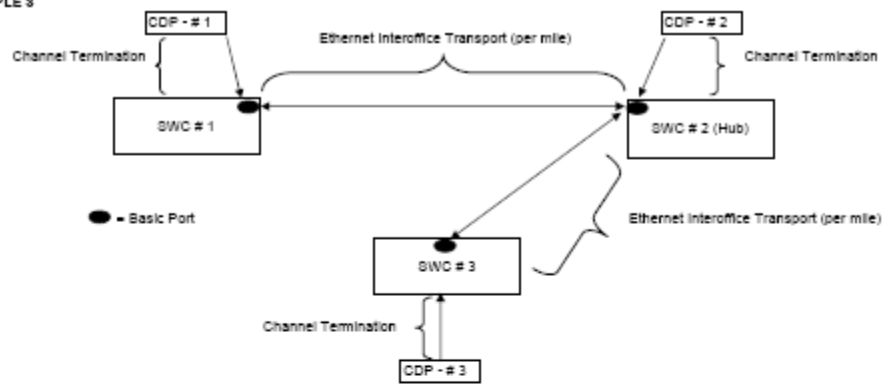

Customer orders multi point connections (3 locations). Customer will be charged 3 Channel Terminations, 3 Basic Ports, Ethernet Interoffice Transport Mileage from Hub (SWC #2) to SWC #1 and Ethernet Interoffice Transport Mileage from Hub (SWC #2) to SWC #3.

DIAGRAM/EXAMPLE 4

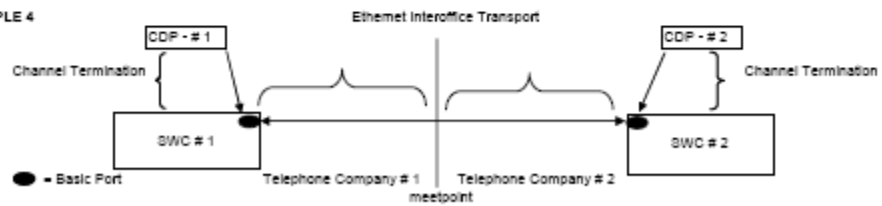

Customer orders 2 connections from adjacent Telephone Companies. CDP # 1 will be billed 1 Channel Termination and 1 Basic Port from Telephone Company # 1. CDP # 2 will be billed 1 Channel Termination and 1 Basic Port from Telephone Company # 2. Ethernet Interoffice Transport will be billed by Telephone Company # 1 for use of its facilities based on mileage between SWC # 1 and the meetpoint between Telephone Company # 1 and Telephone Company # 2. Ethernet Interoffice Transport will be billed by Telephone Company # 2 for the use of its facilities based on mileage between the meetpoint and SWC # 2.

(N)

(N)

Advice No. 08-05

Issued February 22, 2008

Effective March 23, 2008

Issued By CENTURYTEL OF WASHINGTON, INC. d/b/a CenturyTel

P.O. Box 9901, Vancouver, WA

By Chantel Mosby

Title Manager, Tariffs and Compliance

ACCESS SERVICE

12. SPECIALIZED SERVICE OR ARRANGEMENTS (Cont'd)

12.2 Ethernet Service (Cont'd)

12.2.6. Application of Rates (Cont'd)

The following diagram illustratively shows how the Ethernet rate elements are intended to apply to customer orders.

DIAGRAMEXAMPLE 5

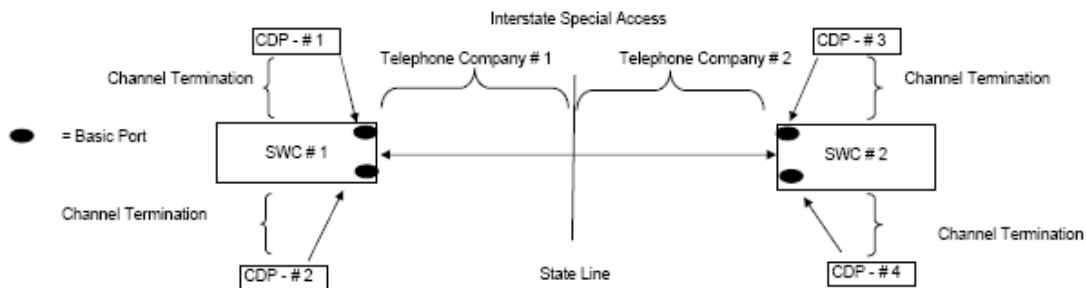

Customer orders 4 connections from adjacent states. CDP # 1 will be billed 1 Channel Termination and 1 Basic Port from Telephone Company # 1.
 CDP # 2 will be billed 1 Channel Termination and 1 Basic Port from Telephone Company # 1.
 CDP # 3 will be billed 1 Channel Termination and 1 Basic Port from Telephone Company # 2.
 CDP # 4 will be billed 1 Channel Termination and 1 Basic Port from Telephone Company # 2.
 Interstate Special Access will be billed by Telephone Company # 1 for the use of its facilities based on mileage between SWC # 1 and the meetpoint.
 Interstate Special Access will be billed by Telephone Company # 2 for the use of its facilities based on mileage between SWC # 2 and the meetpoint.

(N)

(N)

ACCESS SERVICE

12. SPECIALIZED SERVICE OR ARRANGEMENTS (Cont'd)

12.2 Ethernet Service (Cont'd)

(N)

12.2.7. Rate Regulations

A. Types of Rates and Charges

There are two types of rates and charges. They are recurring rates and nonrecurring charges. The rates and charges are described below:

1. Recurring Rates (see 16.5.8, 17.5.8 and 18.5.8)

Recurring rates are rates that apply each month or fraction thereof when an Ethernet service element is provided. For billing purposes, each month is considered to have 30 days.

2. Nonrecurring Charges (see 16.5.8, 17.5.8 and 18.5.8)

Nonrecurring charges are one-time charges that apply for specific work activity (i.e., installation or change to an existing service). The types of nonrecurring charges that apply for Ethernet are installation of service, service rearrangements, moves and design changes.

Except as specified below, these charges are in addition to the Access Order Charge.

(a) Installation of Service

Nonrecurring charges apply for installation of Ethernet CTs and Ethernet Basic Ports ordered by the customer.

(b) Service Rearrangements are changes to existing (i.e., installed) services, which may be administrative only in nature as set forth below or, that involve an actual physical change to the service.

(N)

Advice No. 08-05 Supplement A

Issued February 27, 2008

Effective March 23, 2008

Issued By CENTURYTEL OF WASHINGTON, INC. d/b/a CenturyTel
P.O. Box 9901, Vancouver, WA

By Chantel Mosby

Title Manager, Tariffs and Compliance

ACCESS SERVICE

12. SPECIALIZED SERVICE OR ARRANGEMENTS (Cont'd)

12.2 Ethernet Service (Cont'd)

(N)

12.2.7. Rate Regulations (Cont'd)

A. Types of Rates and Charges (Cont'd)

2. Nonrecurring Charges (Cont'd)

(b) Service Rearrangements (Cont'd)

When the customer elects to decrease the bandwidth capacity on existing Ethernet Basic Ports, and associated Ethernet CTs, the request will be considered a discontinuance of service for the former capacity and start of service for the new capacity. Associated nonrecurring (i.e., installation) charges will apply. New minimum period requirements will be established for the new Ethernet elements. The Ethernet customer will also remain responsible for satisfying all outstanding minimum period charges for the discontinued Ethernet elements.

When the customer elects to increase the bandwidth capacity on existing Ethernet Basic Ports, and associated Ethernet CTs, the request will be considered a discontinuance of service for the former capacity and start of service for the new capacity. Associated nonrecurring (i.e., installation) charges will apply. New minimum period requirements will be established for the new Ethernet elements. Any outstanding minimum period charges associated with the discontinued Ethernet elements that would otherwise be applicable for the bandwidth capacity upgrades described in this paragraph will be waived.

(N)

Advice No. 08-05

Issued February 22, 2008

Effective March 23, 2008

Issued By CENTURYTEL OF WASHINGTON, INC. d/b/a CenturyTel
P.O. Box 9901, Vancouver, WA

By Chantel Mosby Title Manager, Tariffs and Compliance

ACCESS SERVICE

12. SPECIALIZED SERVICE OR ARRANGEMENTS (Cont'd)

12.2 Ethernet Service (Cont'd)

(N)

12.2.7. Rate Regulations (Cont'd)

A. Types of Rates and Charges (Cont'd)

2. Nonrecurring Charges (Cont'd)

(b) Service Rearrangements (Cont'd)

Administrative changes will be made without charge(s) to the Ethernet customer. Administrative changes are as follows:

- Change of customer name,
- Change of customer or customer's end user premises address when the change of address is not a result of physical relocation of equipment,
- Change in billing data (name, address, or contact name or telephone number),
- Change of agency authorization,
- Change of customer circuit identification,
- Change of billing account number,
- Change of customer or customer's end user contact name or telephone number.

(N)

Advice No. 08-05

Issued February 22, 2008

Effective March 23, 2008

Issued By CENTURYTEL OF WASHINGTON, INC. d/b/a CenturyTel

P.O. Box 9901, Vancouver, WA

By Chantel Mosby

Title Manager, Tariffs and Compliance

CENTURYTEL OF WASHINGTON, INC.

ACCESS SERVICE

12. SPECIALIZED SERVICE OR ARRANGEMENTS (Cont'd)

12.2 Ethernet Service (Cont'd)

(N)

12.2.7. Rate Regulations (Cont'd)

A. Types of Rates and Charges (Cont'd)

2. Nonrecurring Charges (Cont'd)

(c) Moves

A move involves a change in the physical location of one of the following:

- The Point of Termination at the customer's premises
- The customer's premises

The charges for moving Ethernet elements are dependent on whether the move is to a different location within the same building, to a different building within the same SWC, or to a different building in a different SWC. The charges specified below apply in addition to any applicable charges for moving any other applicable Special Access Services.

(i) Moves Within the Same Building at a Customer Premise

Ethernet Basic Ports, Ethernet Interoffice Transport are not impacted when an Ethernet customer moves its Point of Termination to a different location within the same building. The charge for moving an Ethernet CT within the same building will be an amount equal to one half of the nonrecurring charge for the Ethernet CT. There will be no change in the minimum period requirements.

(N)

Advice No. 08-05

Issued February 22, 2008

Effective March 23, 2008

Issued By CENTURYTEL OF WASHINGTON, INC. d/b/a CenturyTel

P.O. Box 9901, Vancouver, WA

By Chantel Mosby

Title Manager, Tariffs and Compliance

ACCESS SERVICE

12. SPECIALIZED SERVICE OR ARRANGEMENTS (Cont'd)

12.2 Ethernet Service (Cont'd)

12.2.7. Rate Regulations (Cont'd)

A. Types of Rates and Charges (Cont'd)

2. Nonrecurring Charges (Cont'd)

(c) Moves (Cont'd)

(ii) Moves to a Different Building in the Same SWC

Within the same SWC, Ethernet Basic Ports and Ethernet Interoffice Transport are not impacted when an Ethernet customer moves its Point of Termination to a different building within the same SWC. The move of an Ethernet CT will be treated as a discontinuance and start of service. Associated nonrecurring (i.e., installation) charges will apply and new minimum period requirements will be established for the new services.

The customer will also remain responsible for satisfying all outstanding minimum period charges for the discontinued service.

(iii) Moves to a Different Building in a Different SWC

A move to a different building in a different SWC will be treated as a discontinuance and start of service of all associated Ethernet elements. Associated nonrecurring charges will apply and new minimum period requirements will be established for the new services. The Ethernet customer will also remain responsible for satisfying all outstanding minimum period charges for the discontinued service.

(N)

(N)

Advice No. 08-05

Issued February 22, 2008

Effective March 23, 2008

Issued By CENTURYTEL OF WASHINGTON, INC. d/b/a CenturyTel
P.O. Box 9901, Vancouver, WA

By Chantel Mosby Title Manager, Tariffs and Compliance

CENTURYTEL OF WASHINGTON, INC.

ACCESS SERVICE

12. SPECIALIZED SERVICE OR ARRANGEMENTS (Cont'd)

12.2 Ethernet Service (Cont'd)

(N)

12.2.7. Rate Regulations (Cont'd)

A. Types of Rates and Charges (Cont'd)

3. Discounts (see 16.5.8, 17.5.8 and 18.5.8)

Customers electing longer service terms will be given discounts off the recurring rates. Customers electing a 3 year contract will receive a 10% discount. Customer electing a 5 year contract will receive a 20% discount.

B. Minimum Periods

The minimum period for Ethernet service elements provided to a customer and for which charges are applicable is:

- Twelve months for all Ethernet elements.
- One month notice for all disconnects from the date of disconnect notice.

C. Termination Liability

Customer requesting termination of service prior to the expiration date of the contract term will be liable for a termination liability charge, as described below:

Billing Period	Termination Percentage
12 months	90%
36 months	75%
60 months	60%

$$(\text{Monthly Recurring Charge}) \times (\text{Months Remaining in Contract}) \times (\text{Termination Percentage}) = \text{Termination Liability Charge}$$

D. Contract Expiration

Once the contract term for the Ethernet service has expired, the contract will automatically continue on a month-to-month basis at the same rate as the original contract term. The customer will be responsible for notifying the Telephone Company to request termination.

(N)

ACCESS SERVICE

13. Additional Engineering, Additional Labor and Miscellaneous Charges

In this section, normally scheduled working hours are an employee's scheduled work period in any given calendar day (e.g., 8:00 a.m. to 5:00 p.m.) for the application of rates based on working hours.

13.1 Additional Engineering

Additional Engineering will be provided by the Telephone Company at the request of customer only when:

- (A) a customer requests additional technical information after the Telephone Company has already provided the technical information normally included on the Design Layout Report (DLR) as set forth in 6.1.5 and 7.1.6 preceding.
- (B)
- (C) additional engineering time is incurred by the Telephone Company to engineer a customer's request for a customized service as set forth in 7.1.1 preceding. The Telephone Company will notify the customer that additional engineering charges, as set forth in Sections 16 and 17 following, will apply before any additional engineering is undertaken.

Advice No. 03-28

Issued July 23, 2003

Effective August 23, 2003

Issued By CENTURYTEL OF WASHINGTON, INC. d/b/a CenturyTel
P.O. Box 9901, Vancouver, WA

(C)

By Pamela Donovan Title Supervisor, Tariffs

ACCESS SERVICE

13. Additional Engineering, Additional Labor and Miscellaneous Services (Cont'd)

13.2 Additional Labor (Cont'd)

13.2.3 Standby

Stand by includes all time in excess of one-half (1/2) hour during which Telephone Company personnel stand by to make installation acceptance tests or cooperative tests with a customer to verify facility repair on a given service.

13.2.4 Testing and Maintenance with Other Telephone Companies

Additional testing, maintenance or repair of facilities which connect to facilities of other telephone companies which is in addition to normal effort required to test, maintain or repair facilities provided solely by the Telephone Company.

13.2.5 Other Labor

Other labor is that additional labor not included in 13.2.1 through 13.2.4 preceding, including, but not limited to labor incurred for the installation of inside wire, used to extend the Point of Termination as set forth in 2.1.5 preceding, and labor incurred to accommodate a specific customer request that involves only labor which is not covered by any other section of this tariff.

Advice No. 03-28

Issued July 23, 2003

Effective August 23, 2003

Issued By CENTURYTEL OF WASHINGTON, INC. d/b/a CenturyTel
P.O. Box 9901, Vancouver, WA

(C)

By Pamela Donovan Title Supervisor, Tariffs

ACCESS SERVICE

13. Additional Engineering, Additional Labor and Miscellaneous Services (Cont'd)
- 13.3 Miscellaneous Services
- 13.3.1 Maintenance of Service
- (A) When a customer reports a trouble to the Telephone Company for clearance, the customer shall be responsible for payment of a Maintenance of Service charge when Telephone Company personnel are dispatched to the customer's premises and no trouble is found in the Telephone Company's facilities. This charge will be at the applicable rate listed in Sections 16, 17 and 18 and will begin when personnel are dispatched to the customers premises and end when the personnel return from the customer premises. Failure of Telephone Company personnel to find trouble in Telephone Company facilities will result in no charge if the trouble is actually in those facilities, but not discovered at the time.
- (B) The customer shall be responsible for payment of a Maintenance of Service charge when the Telephone Company dispatches personnel to the customer's premises, and the trouble is in equipment or communications systems provided by other than the Telephone Company or in detariffed CPE provided by the Telephone Company. In either (A) or (B) preceding, no credit allowance will be applicable for the interruption involved if the Maintenance of Service Charge applies.

Advice No. 03-28

Issued July 23, 2003

Effective August 23, 2003

Issued By CENTURYTEL OF WASHINGTON, INC. d/b/a CenturyTel
P.O. Box 9901, Vancouver, WA

(C)

By Pamela Donovan Title Supervisor, Tariffs

ACCESS SERVICE

13. Additional Engineering, Additional Labor and Miscellaneous Services (Cont'd)

13.3 Miscellaneous Services (Cont'd)

13.3.2 Restoration Priority

The Telephone Company will arrange a Special Access Service for Restoration Priority on receipt of certification in conformance with Part 64, Subpart D, Appendix A of the Federal Communication Commission's Rules and Regulations. A charge applies when a request to provide or change a Restoration Priority is received subsequent to the issuance of an Access Order to install the service. No charge applies when a Restoration Priority is discontinued.

13.3.3 Presubscription

(A) IntraLATA Dialing Parity

- (1) IntraLATA Dialing Parity is available with FGD, Operator or Traditional signaling. When intraLATA Dialing Parity is made available in an end office at some time after the end office has converted to intraLATA equal access, the balloting and allocation process for the intraLATA Dialing Parity will not apply.

A single line end user or agent must select only one Interexchange Carrier (IC) as an intraLATA primary interexchange carrier (IPIC). Multiline end users or agents and multiline hunt group end users or agents have two options in selecting an IPIC. Under option one, an end user or agent may select one IC for all its lines. Under option two, an end user or agent may designate specific lines to different ICs.

An IC obtaining service commitments from end users and agents directly must provide an IC End User and Agent List to the Telephone Company accompanied by a document certifying that the IC does have end user and agent signed statements. The Telephone Company will process all IC End User and Agent Lists that are received 20 days prior to conversion of an end office to equal access.

- (2) When a discrepancy is determined regarding an end user's or agent's designation of an IPIC, the IC whose letter of agency bears the latest authorization date shall become the end user's or agent's IPIC.

Advice No. 03-28

Issued July 23, 2003

Effective August 23, 2003

Issued By CENTURYTEL OF WASHINGTON, INC. d/b/a CenturyTel
P.O. Box 9901, Vancouver, WA

(C)

By Pamela Donovan Title Supervisor, Tariffs

ACCESS SERVICE

13. Additional Engineering, Additional Labor and Miscellaneous Services (Cont'd)

13.3 Miscellaneous Services (Cont'd)

13.3.3 Presubscription (Cont'd)

(A) IntraLATA Dialing Parity(Cont'd)

(3) IntraLATA Presubscription Change Charge Application

- (a) End users and agents making their initial IPIC selections during the four months following the applicable end office conversions date are not subject to a presubscription charge

Within the four months after the applicable end office conversion to equal access, an end user or agent may elect to change to another IPIC at no charge once during that period. After the four month period has elapsed, a nonrecurring charge as set forth in (5)(a) following will apply.

- (b) New end users and agents, who will be served by end offices equipped with equal access, will be asked to select an IPIC at the time they place an order with the Telephone Company for Telephone Exchange Service. New end users and agents will be offered a list of participating carriers to aid in their selection of an IPIC. There will be no charge for this initial selection.

After the end user's or agent's initial IPIC selection, the end user or agent may elect to change to another IPIC at no charge once during the four month period. After the four month period has elapsed, a charge as set forth in (5)(a) following, applies.

- (c) New end users who do not select an IPIC must dial an access code to route their intraLATA toll calls until they make an selection.

Advice No. 03-28

Issued July 23, 2003

Effective August 23, 2003

Issued By CENTURYTEL OF WASHINGTON, INC. d/b/a CenturyTel
P.O. Box 9901, Vancouver, WA

(C)

By Pamela Donovan

Title Supervisor, Tariffs

ACCESS SERVICE

13. Additional Engineering, Additional Labor and Miscellaneous Services (Cont'd)
- 13.3 Miscellaneous Services (Cont'd)
- 13.3.3 Presubscription (Cont'd)
- (A) IntraLATA Dialing Parity (Cont'd)
- (3) IntraLATA Presubscription Change Charge Application (Cont'd)
- (d) The Telephone Company will make post conversion changes in the end user's or agent's IPIC assignment pursuant to an IC provided list of customers, accepted by the Telephone Company under the conditions set forth in (1) and (2) preceding. Should an end user or agent dispute the authorization of the change in IPIC assignment, the Telephone Company may, in order to resolve the dispute, require that the IC requesting the change submit a letter of agency. If the IC cannot produce a customer signed letter of agency or confirmation from the end user or agent, and the Telephone Company resolves the dispute in favor of the end user or agent, the IC will be billed two nonrecurring charges; an intraLATA presubscription charge as set forth in Sections 16, 17 and 18 following for the change to the disputed IC, and an unauthorized intraLATA presubscription change charge as specified in Sections 16, 17 and 18 following for restoring the end user's or agent's proper IC assignment. If the IC produces the required letter of agency within 30 days of the Telephone Company's request, the end user or agent will be billed two presubscription change charges as specified in Sections 16, 17 and 18 following in lieu of the IC. Charges are only applicable if a change in an end user's or agent's IC selection has actually been implemented in the switch.
- (4) IntraLATA Dialing Parity Rate Application
- The IntraLATA Dialing Parity rate recovers the cost of conversion of the Telephone Company switches to implement IntraLATA Dialing Parity. The IntraLATA Dialing Parity rate is applied per minute to all originating intrastate intraLATA access minutes. The IntraLATA Dialing Parity rate will be in effect for a period of 36 months, beginning February 6, 1999 and ending February 5, 2002.

Advice No. 03-28

Issued July 23, 2003

Effective August 23, 2003

Issued By CENTURYTEL OF WASHINGTON, INC. d/b/a CenturyTel
 P.O. Box 9901, Vancouver, WA

(C)

By Pamela Donovan Title Supervisor, Tariffs

WN U-4

Second Revised Sheet No. 352
Cancels
First Revised Sheet No. 352
CENTURYTEL OF WASHINGTON, INC.

(C)

ACCESS SERVICE

13. Additional Engineering, Additional Labor and Miscellaneous Services (Cont'd)
13.3 Miscellaneous Services (Cont'd)

Advice No. 03-28

Issued July 23, 2003 Effective August 23, 2003
Issued By CENTURYTEL OF WASHINGTON, INC. d/b/a CenturyTel
 P.O. Box 9901, Vancouver, WA
By Pamela Donovan Title Supervisor, Tariffs

(C)

WN U-4

Second Revised Sheet No. 354
Cancels
First Revised Sheet No. 354
CENTURYTEL OF WASHINGTON, INC.

(C)

ACCESS SERVICE

13. Additional Engineering, Additional Labor and Miscellaneous Services (Cont'd)
13.3 Miscellaneous Services (Cont'd)

Advice No. 03-28

Issued July 23, 2003 Effective August 23, 2003
Issued By CENTURYTEL OF WASHINGTON, INC. d/b/a CenturyTel
 P.O. Box 9901, Vancouver, WA
By Pamela Donovan Title Supervisor, Tariffs

(C)

ACCESS SERVICE

13. Additional Engineering, Additional Labor and Miscellaneous Services (Cont'd)

13.3 Miscellaneous Services (Cont'd)

13.3.5 Testing Services

Testing Services offered under this section of the tariff are optional and subject to the rates and charges set forth in Sections 16, 17 and 18 following. In addition, the Telephone

Company as part of the ongoing work to maintain the continued satisfactory performance of the access services ordered by the customer, may perform periodic tests at no additional charge, as described in 6.1.6 and 7.1.8 preceding.

Testing services are normally provided by Telephone Company personnel at Telephone Company locations. However, provisions are made in (A)(5) and (B)(2) following for a customer to request Telephone Company personnel to perform testing services at the customer's premises. The offering of Testing Services under this section of the tariff is made subject to the availability of the necessary qualified personnel and test equipment at the various test locations mentioned in (A), (B) and (C) following:

(A) Switched Access Service

Testing Services for Switched Access are comprised of (a) tests which are performed during the installation of a Switched Access Service, and (b) tests which are performed after acceptance of such access services by a customer, i.e., in-service tests at no additional charge for scheduled tests. These in-service tests may be further divided into two broad categories of tests: scheduled and non-scheduled.

Scheduled tests are those tests performed by the Telephone Company on a regular basis, e.g., monthly, which result in the measurement of Switched Access Service. Scheduled tests may be done on an automatic basis (no Telephone

Advice No. 03-28

Issued July 23, 2003

Effective August 23, 2003

Issued By CENTURYTEL OF WASHINGTON, INC. d/b/a CenturyTel
 P.O. Box 9901, Vancouver, WA

(C)

By Pamela Donovan Title Supervisor, Tariffs

ACCESS SERVICE

13. Additional Engineering, Additional Labor and Miscellaneous Services (Cont'd)

13.3 Miscellaneous Services (Cont'd)

13.3.5 Testing Services (Cont'd)

(A) Switched Access Service (Cont'd)

(5) Nonscheduled Testing

Nonscheduled Testing (NST) of Switched Access Services is where:

the customer provides remote office test lines and 105 test lines with associated responders or their functional equivalent or

the Telephone Company provides a technician at its office(s) and the customer provides a technician at its premises, with suitable test equipment to perform the required tests, or

the Telephone Company provides a technician at its office(s), at the customer premises with suitable test equipment to perform the required tests

Nonscheduled Tests may consist of any tests, e.g., loss, noise, slope, envelope delay, which the customer may require.

(6) Obligations of the Customer

(A) The customer shall provide the Remote Office Test Line priming data to the Telephone Company, as appropriate, to support NST as set forth in 13.3.5(A)(5) preceding.

(B) The customer shall make the facilities to be tested available to the Telephone Company at times mutually agreed upon.

Advice No. 03-28

Issued July 23, 2003

Effective August 23, 2003

Issued By CENTURYTEL OF WASHINGTON, INC. d/b/a CenturyTel
P.O. Box 9901, Vancouver, WA

(C)

By Pamela Donovan Title Supervisor, Tariffs

ACCESS SERVICE

13. Additional Engineering, Additional Labor and Miscellaneous Services (Cont'd)
13.3 Miscellaneous Services (Cont'd)
13.3.5 Testing Services (Cont'd)
(B) Special Access Service

The Telephone Company will, at the request of an Customer, provide assistance in performing specific tests requested by the customer.

(1)

(2) Nonscheduled Testing (NST)

When a customer provides a technician at its premises, with suitable test equipment to perform the required tests, the Telephone Company will provide a technician at its office for the purpose of conducting Nonscheduled Testing. At the customer's request, the Telephone Company will provide a technician at the customer's premises. Nonscheduled tests may consist of any tests, e.g., loss, noise, slope, envelope delay, which the customer may require.

Advice No. 03-28

Issued July 23, 2003

Effective August 23, 2003

Issued By CENTURYTEL OF WASHINGTON, INC. d/b/a CenturyTel
P.O. Box 9901, Vancouver, WA

(C)

By Pamela Donovan

Title Supervisor, Tariffs

ACCESS SERVICE

- 13. Additional Engineering, Additional Labor and Miscellaneous Services (Cont'd)
- 13.3 Miscellaneous Services (Cont'd)
- 13.3.6 Provision of Access Service Billing Information
 - (A) The customer will receive its monthly bills in standard paper format.
 - (B) At the option of the customer, and for an additional charge:
 - (1) Customer monthly bills may be provided on magnetic tape.

Advice No. 03-28

Issued July 23, 2003

Effective August 23, 2003

Issued By CENTURYTEL OF WASHINGTON, INC. d/b/a CenturyTel
P.O. Box 9901, Vancouver, WA

(C)

By Pamela Donovan Title Supervisor, Tariffs

ACCESS SERVICE

14. Exceptions to Access Service Offerings

The services offered under the provisions of this tariff are subject to availability as set forth in 2.I.4 preceding. In addition, the following exceptions apply:

14.1 The following items are not offered in the operating territory of this Company.

(Name of Item and USOC)

14.2 The following items are offered only to existing customers at their existing terminal locations associated with existing service arrangements:

(Name of Item, USOC, Rates, Charges and any unique regulations that may be applicable)

14.3 The following items are offered only to existing customers at their existing terminal locations associated with existing service arrangements and to fill out existing capacity:

(Name of Item, USOC, Rates, Charges and any unique regulations that may be applicable)

Advice No. 03-28

Issued July 23, 2003

Effective August 23, 2003

Issued By CENTURYTEL OF WASHINGTON, INC. d/b/a CenturyTel
P.O. Box 9901, Vancouver, WA

(C)

By Pamela Donovan Title Supervisor, Tariffs

ACCESS SERVICE

15. Rate Centers

This section sets forth the wire centers within the Telephone Company operating territory. The Company Wire Center location is identified by Vertical and Horizontal (V&H) coordinates. The Company-provided transport mileage is the airline mileage provided by the Company to a point of interface with the customer or other exchange carrier for special access.

15.1 Location Information

<u>Exchange</u>	<u>Wire Center</u>		<u>Point of Interface</u>	
	<u>V</u>	<u>H</u>	<u>V</u>	<u>H</u>
Ames Lake	6323	8842	6354	8814
Arletta	6410	8940	6413	8920
Basin City	6511	8403	6518	8467
Blakely Island	6127	8980	6335	8897
Carnation	6322	8834	6353	8813
Cheney	6286	8195	6268	8187
Chewelah	6117	8236	6166	8237
Clallam Bay	6213	9186	6236	9135
Clearwater	6363	9183	6236	9135
Connell	6490	8363	6447	9023
Creston	6490	8363	6499	8416
Creston	6246	8340	6240	8402
Davenport	6262	8283	6250	8200
Eastsound	6104	8998	6335	8897
Elma	6480	9047	6447	9023
Eloptia	6538	8381	6536	8453
Fall City	6339	8830	6353	8813
Forks	6280	9201	6236	9135
			6447	9023

 Advice No. 03-28

Issued July 23, 2003

Effective August 23, 2003

 Issued By CENTURYTEL OF WASHINGTON, INC. d/b/a CenturyTel
 P.O. Box 9901, Vancouver, WA

(C)

By Pamela Donovan

Title Supervisor, Tariffs

ACCESS SERVICE

15. Rate Centers (Cont'd)15.1 Location Information

<u>Exchange</u>	<u>Wire Center</u>		<u>Point of Interface</u>	
	<u>V</u>	<u>H</u>	<u>V</u>	<u>H</u>
Friday Harbor	6139	9009	6335	8897
Gig Harbor	6400	8929	6406	8920
Inchelium	6124	8307	6166	8237
Kahlotus	6490	8317	6504	8409
Kettle Falls	6051	8295	6166	8237
Kingston	6296	8922	6314	8912
Lakebay	6414	8954	6415	8917
Long Beach	6630	9135	6650	9109
Lopez	6152	8990	6335	8897
Mathews Corner	6552	8498	6545	8537
McCleary	6468	9025	6447	9023
Medical Lake	6270	8212	6260	8197
Mesa	6512	8382	6519	8454
Montesano	6488	9075	6447	9023
Morton	6565	8870	6482	8891
Neah Bay	6190	9234	6236	9135
North Bend	6354	8814	6447	9023
North Bend	6354	8814	6354	8814
North Vashon	6362	8914	6351	8906

Advice No. 03-28

Issued July 23, 2003

Effective August 23, 2003

Issued By CENTURYTEL OF WASHINGTON, INC. d/b/a CenturyTel
 P.O. Box 9901, Vancouver, WA

By Pamela Donovan

Title Supervisor, Tariffs

(C)

ACCESS SERVICE

15 Rate Centers (Cont'd)15.1 Location Information

<u>Exchange</u>	<u>Wire Center</u>		<u>Point of Interface</u>	
	<u>V</u>	<u>H</u>	<u>V</u>	<u>H</u>
Ocean Park	6600	9136	6637	9095
Orting	6446	8863	6442	8869
Packwood	6548	8781	6444	8880
Puget Sound	6664	9030	6665	9029
Randle	6567	8825	6456	8885
Reardan	6253	8244	6249	8195
Snoqualmie Pass	6368	8757	6367	8761
South Prairie	6437	8858	6429	8165
Spangle	6296	8164	6294	8165
Twisp	6141	8591	6175	8592
Valley	6141	8236	6176	8217
Vashon	6378	8911	6367	8907
Washtucna	6461	8283	6488	8405
Winthrop	6116	8592	6176	8594

 Advice No. 03-28

Issued July 23, 2003

Effective August 23, 2003

 Issued By CENTURYTEL OF WASHINGTON, INC. d/b/a CenturyTel
 P.O. Box 9901, Vancouver, WA

(C)

By Pamela Donovan

Title Supervisor, Tariffs

ACCESS SERVICE

15 Rate Centers (Cont'd)
 15.2 Service Information

<u>Exchange</u>	<u>CLLI Code</u>	<u>CC</u>	<u>LATA</u>	<u>NPA</u>	<u>NXX</u>
Ames Lake	ASLKWAXARS1	2408	674	425	880
Arletta	ARLTWAXXRS0	2408	674	253	265
Basin City	BSCTWAXXRS0	2408	676	509	269
Blakely Island	BLKIWAXXRS0	2422	674	360	375
Carnation	CRNTWAXXRS0	2408	674	425	333
Cheney	CHNYWAXADS0	2408	676	509	235 359 559
Chewelah	CHWLWAXXDS0	2408	676	509	935
Clallam Bay	CLBYWAXXRS0	2408	674	360	963
Clearwater	CLWRWAXARS0	2408	674	360	962
Connell	CNNLWAXADS0	2408	676	509	234
Creston	CETNWAXXRS0	2408	676	509	636
Davenport	DVPTWAXXRS0	2408	676	509	725
Eastsound	ESNDWAXARS0	2422	674	360	376
Elma	ELMAWAXADS1	2408	674	360	482
Eltopia	ELTPWAXXRS0	2408	676	509	297
Fall City	FLCYWAXARS0	2408	674	425	222
Forks	FRKSWAXADS1	2408	674	360	327 374

Advice No. 03-28

Issued July 23, 2003

Effective August 23, 2003

Issued By CENTURYTEL OF WASHINGTON, INC. d/b/a CenturyTel
 P.O. Box 9901, Vancouver, WA

(C)

By Pamela Donovan Title Supervisor, Tariffs

ACCESS SERVICE

15 Rate Centers (Cont'd)
 15.2 Service Information (Cont'd)

<u>Exchange</u>	<u>CLLI Code</u>	<u>CC</u>	<u>LATA</u>	<u>NPA</u>	<u>NXX</u>
Friday Harbor	FRHRWAXADS1	2422	674	360	317 378 370
Gig Harbor	GGHRWAXADS0	2408	674	253	530 549 851 857 858
Inchelium	ICHLWAXARS0	2408	676	509	722
Kahlotus	KHLTWAXARS0	2408	676	509	282
Kettle Falls	KTFLWAXADS0	2408	676	509	738
Kingston	KGTNWAXADS0	2408	674	360	297 638
Lakebay	LKBYWAXARS0	2408	674	253	884
Long Beach	LNBHWAXADS0	2408	672	360	642 777
Lopez	LOPZWAXXRS0	2422	674	360	468
Mathews Corner	MTCOWAXXRS0	2408	676	509	266
McCleary	MCCLWAXARS0	2408	674	360	495
Medical Lake	MDLKWAXXRS0	2408	676	509	299
Mesa	MESAWAXXRS0	2408	676	509	265
Montesano	MNTSWAXARS0	2408	674	360	249
Morton	MRTNWAXXDS0	2408	674	360	492 496 498
Neah Bay	NHBYWAXXRS0	2408	674	360	645
North Bend	NBNDWAXADS1	2408	674	425	831 888
North Vashon	VSHNWAXBRS1	2408	674	206	567

Advice No. 03-28

Issued July 23, 2003

Effective August 23, 2003

Issued By CENTURYTEL OF WASHINGTON, INC. d/b/a CenturyTel
 P.O. Box 9901, Vancouver, WA

(C)

By Pamela Donovan Title Supervisor, Tariffs

WN U-4

Second Revised Sheet No. 368
Cancels
First Revised Sheet No. 368
CENTURYTEL OF WASHINGTON, INC.

(C)

ACCESS SERVICE

Advice No. 03-28

Issued July 23, 2003 Effective August 23, 2003
Issued By CENTURYTEL OF WASHINGTON, INC. d/b/a CenturyTel
 P.O. Box 9901, Vancouver, WA
By Pamela Donovan Title Supervisor, Tariffs

(C)

WN U-4

Second Revised Sheet No. 369
Cancels
First Revised Sheet No. 369
CENTURYTEL OF WASHINGTON, INC.

(C)

ACCESS SERVICE

Advice No. 03-28

Issued July 23, 2003 Effective August 23, 2003
Issued By CENTURYTEL OF WASHINGTON, INC. d/b/a CenturyTel
 P.O. Box 9901, Vancouver, WA
By Pamela Donovan Title Supervisor, Tariffs

(C)

ACCESS SERVICE

16. Rates and Charges

Rates and charges in this section apply to the following CenturyTel of Washington, Inc. and CenturyTel of Inter Island, Inc. exchanges:

Ames	Fox Island	Neah Bay
Arletta	Lake Friday	North Bend
Basin City	Gig Harbor	Ocean Park
Beaver	Glenoma	Orting
Blakely	Hansville	Packwood
Carnation	Hunters	Randle
Cheney	Kahalotus	Reardon
Chewelah	Kettle Falls	Snoqualmie Pass
Chinook	Kingston	South Prairie
Clallum Bay	Lakebay	Spangle
Clearwater	Long Beach	Twisp
Connell	Lopez	Vashon
Creston	Mathews Corner	Washtucna
Davenport	McCleary	Winthrop
East Sound	Medical Lake	
Elma	Mesa	
Eltopia	Mineral	
Fall City	Montesano	
Forks	Morton	

Advice No. 03-28

Issued July 23, 2003

Effective August 23, 2003

Issued By CENTURYTEL OF WASHINGTON, INC. d/b/a CenturyTel
 P.O. Box 9901, Vancouver, WA

(C)

By Pamela Donovan Title Supervisor, Tariffs

ACCESS SERVICE

16. Rates and Charges ⁽¹⁾ (C)

16.1 Carrier Common Line Access Service
 Regulations, Rates and Charges for Carrier Common Line Access Service are the same as those set forth in WASHINGTON EXCHANGE CARRIER ASSOCIATION Tariff No. WNU-1.

16.2 Access Ordering
 Regulations concerning Access Ordering are set forth in Section 5. preceding.

	<u>USOC</u> <u>Reference</u>	<u>Charge</u>	Tariff
(A) <u>Access Order Charge</u> Per order		N/A	
(B) <u>Service Date Change Charge</u> Per order, per occurrence		\$25.00	5.2.2(A)
(C) <u>Partial Cancellation Charge</u> Per order, per occurrence	See Section 5.2.2(B), preceding		
(D) <u>Design Change Charge</u> Per order, per occurrence		\$25.00	5.2.2(C)
(E) <u>Expedited Order Charge</u> Per order, per occurrence	See Section 5.2.2(D) preceding		
(F) <u>Cancellation of Access Order Charge</u> Per order, per occurrence	See Section 5.2.3 preceding		

(1) See Sheet 370 for applicable exchanges (C)

Advice No. 05-05

Issued June 7, 2005	Effective July 7, 2005
Issued By	CENTURYTEL OF WASHINGTON, INC. d/b/a CenturyTel
	P.O. Box 9901, Vancouver, WA
By	Pamela Donovan Title Supervisor, Tariffs

ACCESS SERVICE

16. Rates and Charges (Cont'd) ⁽¹⁾ (C)

16.3 Switched Access Service
 Regulations concerning Switched Access are set forth in Section 6 preceding.

16.3.1 <u>Nonrecurring Charges</u>	<u>USOC</u>	<u>Nonrecurring Charge</u>	<u>Tariff Reference</u>
(A) <u>Local Transport Installation</u> Per Entrance Facility			6.4.1(B)(1)
Voice Grade Four-Wire	NEFT4	\$56.00	
High Capacity DS1	NEFD1	\$400.00	
High Capacity DS3	NEFD3	\$ 750.00	
(B) <u>Trunk Activation</u> Per 24 Trunks Activated or Fraction thereof on a Per Order basis	NDTTA	\$418.00	6.4.1(B)(1)
(C) <u>FGC and FGD Trunk Conversion</u> Multifrequency Address Signaling to SS7 Signaling or SS7 Signaling to Multifrequency Address Signaling Per 24 Trunks Converted or Fraction thereof on a Per Order Basis	SS7TC	\$210.00	6.4.1(B)(3)
(D) <u>Common Channel Signaling</u> <u>Network Connection</u> Per Signaling Entrance Facility			
DS0	NCSEF	\$56.00	
DS1	NC1EF	\$400.00	

(1) See Sheet 370 for applicable exchanges (C)

Advice No. 05-05

Issued June 7, 2005	Effective July 7, 2005
Issued By	CENTURYTEL OF WASHINGTON, INC. d/b/a CenturyTel
	P.O. Box 9901, Vancouver, WA
By	Pamela Donovan Title Supervisor, Tariffs

ACCESS SERVICE

16. Rates and Charges (Cont'd) ⁽¹⁾ (C)
 16.3 Switched Access Service (Cont'd)

16.3.2 Local Transport

(A) <u>Premium Access</u>	<u>USOC</u>	<u>Monthly Rate</u>	<u>Tariff Reference</u>
(1) <u>Entrance Facility</u> Per Termination			6.1.3(A)(1)
Voice Grade Two-Wire	EFT2	\$65.00	
Voice Grade Four-Wire	EFT4	\$85.00	
High Capacity DS1	EFDS1	\$150.00	
High Capacity DS3	EFDS3	\$2,400.00	
Per Mile, Over 3 Miles			
High Capacity DS1	HCCTPM	N/A	
High Capacity DS3	H3CTPM	N/A	
(2) <u>Direct Trunked Transport</u>			6.1.3(A)(2)
<u>Direct Trunked Facility</u> Per Mile			
Voice Grade	DVCMF	\$1.35	
High Capacity DS1	D1CMF	\$10.66	
High Capacity DS3	D3CMF	\$225.00	
<u>Direct Trunked Termination</u> Per Termination			
Voice Grade	DVCMT	\$40.00	
High Capacity DS1	D1CMT	\$150.00	
High Capacity DS3	D3CMT	\$500.00	

(1) See Sheet 370 for applicable exchanges (C)

Advice No. 05-05

Issued June 7, 2005	Effective July 7, 2005
Issued By	CENTURYTEL OF WASHINGTON, INC. d/b/a CenturyTel
	P.O. Box 9901, Vancouver, WA
By	Pamela Donovan
	Title Supervisor, Tariffs

ACCESS SERVICE

16. Rates and Charges (Cont'd) ⁽¹⁾ (C)
 16.3 Switched Access Service (Cont'd)
 16.3.2 Local Transport (Cont'd)

(A) <u>Premium Access</u> (Cont'd)	<u>USOC</u>	<u>Monthly Rate</u>	<u>Tariff Reference</u>
(3) <u>Tandem Switched Transport</u>			6.1.3(A)(3)
<u>Tandem Switched Facility</u> Per Access Minute Per Mile	LTF	\$0.000120	
<u>Tandem Switched Termination</u> Per Access Minute Per Termination	LTT	\$0.001690	
<u>Tandem Switching</u> Per Access Minute Per Tandem	LTTAN	\$0.004579	
(B) <u>Non-Premium Access</u>			
<u>Tandem Switched Facility</u> Per Access Minute Per Mile	LTF	\$0.000100	
<u>Tandem Switched Termination</u> Per Access Minute Per Termination	LTT	\$0.001405	
<u>Tandem Switching</u> Per Access Minute Per Tandem	LTTAN	\$0.004579	
(C) <u>Multiplexing</u>			6.1.3(A)(5)
Per Arrangement DS3 to DS1	MUX31	\$385.00	
DS1 to Voice	MUX10	\$300.00	
DS1 to DS0	MUX10	\$300.00	

(1) See Sheet 370 for applicable exchanges (C)

Advice No. 05-05

Issued June 7, 2005	Effective July 7, 2005
Issued By	CENTURYTEL OF WASHINGTON, INC. d/b/a CenturyTel
	P.O. Box 9901, Vancouver, WA
By	Pamela Donovan Title Supervisor, Tariffs

ACCESS SERVICE

16. Rates and Charges (Cont'd) ⁽¹⁾ (C)
 16.3 Switched Access Service (Cont'd)
 16.3.2 Local Transport (Cont'd)

	<u>USOC</u>	<u>Monthly Rate</u>	<u>Tariff Reference</u>
(D) <u>Common Channel Signaling Network Connection</u>			
(1) <u>Signaling Network Access Link</u> 6.10.3			
<u>Signaling Mileage Facility</u>			
Per Mile			
DS0	CCCMF	\$1.35	
DS1	C1CMF	\$10.66	
<u>Signaling Mileage Termination</u>			
Per Termination			
DS0	CCCMT	\$40.00	
DS1	C1CMT	\$150.00	
<u>Signaling Entrance Facility</u>			
Per Facility			
DS0	CCSEF	\$85.00	
DS1	C1SEF	\$150.00	
Per Mile, Over 3 Miles			
DS1	CSEFPM	\$65.00	
(2) <u>STP Port</u>			
Per Port	STPPT	\$900.00	

(1) See Sheet 370 for applicable exchanges (C)

Advice No. 05-05

Issued June 7, 2005	Effective July 7, 2005
Issued By	CENTURYTEL OF WASHINGTON, INC. d/b/a CenturyTel
	P.O. Box 9901, Vancouver, WA
By	Pamela Donovan
	Title Supervisor, Tariffs

ACCESS SERVICE

16.	<u>Rates and Charges</u> (Cont'd) ⁽¹⁾		(C)
	16.3 <u>Switched Access Service</u> (Cont'd)		
	16.3.2 <u>Local Transport</u> (Cont'd)		
		USOC	Monthly Rate
			Tariff Reference
	(E) <u>Network Blocking</u> (Applies to FGD only) Per Blocked Call	NBCPC	\$0.0076 6.7.9
	(F) <u>800 Data Base Access Service Queries</u> Per Query		6.10.3
	Basic	800B	\$0.011770
	Vertical Feature	800V	\$0.011770

(1) See Sheet 370 for applicable exchanges (C)

Advice No. 05-05
 Issued June 7, 2005 Effective July 7, 2005
 Issued By CENTURYTEL OF WASHINGTON, INC. d/b/a CenturyTel
 P.O. Box 9901, Vancouver, WA
 By Pamela Donovan Title Supervisor, Tariffs

ACCESS SERVICE

16. Rates and Charges (Cont'd) ⁽¹⁾

16.3 Switched Access Service (Cont'd)

16.3.3 End Office

(A) <u>Local Switching</u>	<u>Monthly Rate</u>	<u>Tariff Reference</u>
(1) <u>Premium</u>		
Local Switching 1 – Originating Per Access Minute	\$0.041239	
Local Switching 2 – Terminating Per Access Minute	\$0.007148	
(2) <u>Non-Premium</u>		
Originating Per Access Minute	\$0.041239	
Terminating Per Access Minute	\$0.007148	
(B) <u>Line Terminations</u>		
(1) <u>Access Line Termination</u>		
Premium	N/A	
Transitional	N/A	
(C) <u>Intercept Intercept Charge</u>		
Premium	N/A	
Transitional	N/A	
(D) <u>Interim USF Additive</u>		
Per Terminating Access Minute	\$0.016851	
(E) <u>Reserved For Future Use</u>		(C) (D) (D)
(F) <u>Reserved For Future Use</u>		(C) (D) (D)

⁽¹⁾ See Sheet 370 for applicable exchanges

ACCESS SERVICE

16. Rates and Charges (Cont'd) ⁽¹⁾

(C)

16.4 Special Access Service

Regulations concerning Special Access Service are set forth in Section 7 preceding.

16.4.1 Nonrecurring Charges(A) Special Access Line

(1) <u>Installation</u>	<u>USOC</u>	<u>Nonrecurring Charge</u>	<u>Tariff Reference</u>
2 Wire		\$56.00	
4 Wire		\$56.00	
ISDN Repeater		N/A	
 (2) <u>Multiplexing</u>			
Voice to Narrowband Per Arrangement	NMQX	\$ 72.00	
DS1 to Voice Per Arrangement	NMXDS	\$203.00	
 (3) <u>Optional Facility Interface Combinations</u>			
<u>Narrowband</u>			
DB-43 TT (for use with NB4)	N9E2	\$ 38.00	
DB-10 IA (for use with NB5)	N9F1	\$ 38.00	
DB-43 IA (for use with NB5)	N9F2	\$ 38.00	

(1) See Sheet 370 for applicable exchanges

(C)

Advice No. 05-05

Issued June 7, 2005

Effective July 7, 2005

Issued By CENTURYTEL OF WASHINGTON, INC. d/b/a CenturyTel
 P.O. Box 9901, Vancouver, WA

By Pamela Donovan Title Supervisor, Tariffs

ACCESS SERVICE

16. Rates and Charges (Cont'd)⁽¹⁾

(C)

16.4 Special Access Service

Regulations concerning Special Access Service are set forth in Section 7 preceding.

16.4.1 Nonrecurring Charges

(A) Special Access Line

(3) Optional Facility Interface Combinations (Cont'd)

<u>Voice Grade</u>	<u>USOC</u>	<u>Nonrecurring Charge</u>	<u>Tariff Reference</u>
DB DA (for use with VG)	N9XQ	\$ 38.00	
DS AC (for use with VG)	N9KV	\$ 50.00	
DS DA (for use with VG)	N9KT	\$ 38.00	
DS EA (for use with VG)	N9K8	\$ 38.00	
DS LS (for use with VG)	N9KX	\$ 38.00	
DS NO (for use with VG)	N9KU	\$ 38.00	
LS SF (for use with VG)	N9YG	\$ 44.00	
NO DA (for use with VG)	N9X2	\$ 38.00	
NO NO (for use with VG)	N9GE	\$ 38.00	
SF LS (for use with VG)	N9MD	\$ 50.00	
SF EA (for use with VG)	N9PO	\$ 50.00	
SF AC (for use with VG)	N9L5	\$ 50.00	
SF GS (for use with VG)	N9PN	\$ 50.00	

(1) See Sheet 370 for applicable exchanges

(C)

Advice No. 05-05

Issued June 7, 2005

Effective July 7, 2005

Issued By CENTURYTEL OF WASHINGTON, INC. d/b/a CenturyTel
 P.O. Box 9901, Vancouver, WA

By Pamela Donovan

Title Supervisor, Tariffs

ACCESS SERVICE

16. Rates and Charges (Cont'd) ⁽¹⁾ (C)

16.4 Special Access Service (Cont'd)

16.4.1 Nonrecurring Charges(Cont'd)

(A) Special Access Line

	<u>USOC</u>	<u>Nonrecurring Charge</u>	<u>Tariff Reference</u>
(4) <u>Bridging</u>			
(a) Narrowband Bridges			
Telegraph Bridging (available with NB4 & NB5)			
2 Wire	BCNT2	\$ 12.00	
4 Wire	BCNT4	\$ 18.00	
(b) Voice Grade Bridges			
Voice Bridging (available with VG)			
2 Wire	BCNV2	\$ 12.00	
4 Wire	BCNV4	\$ 18.00	
Data Bridging (available with VG)			
2 Wire	BCND2	\$ 12.00	
4 Wire	BCND4	\$ 18.00	
(5) <u>Conditioning</u>			
C-Type	NX1C	\$184.00	
DA Type	NXDC	\$184.00	
(6) <u>Improved Return Loss</u>			
2 Wire	NRL2W	\$ 37.00	
4 Wire	NRL4W	\$ 74.00	

(1) See Sheet 370 for applicable exchanges

(C)

Advice No. 05-05

Issued June 7, 2005

Effective July 7, 2005

Issued By CENTURYTEL OF WASHINGTON, INC. d/b/a CenturyTel
 P.O. Box 9901, Vancouver, WA

By Pamela Donovan

Title Supervisor, Tariffs

ACCESS SERVICE

16. Rates and Charges (Cont'd) ⁽¹⁾ (C)
 16.4 Special Access Service (Cont'd)
 16.4.1 Nonrecurring Charges (Cont'd)

(B) <u>High Capacity Access Service</u>	<u>USOC</u>	<u>Monthly Rate</u>	<u>Tariff Reference</u>
(1) <u>Installation</u>			
(a) High Capacity Access Line	NCEUC	\$ 94.00	
(b) High Capacity Transport	NCSTB	\$418.00	

16.4.2 <u>Surcharge for Special Access Service</u>	<u>USOC</u>	<u>Monthly Rate</u>	<u>Tariff Reference</u>
<u>Special Access Surcharge</u> Per Voice Grade Equivalent		\$0.00	7.4.2

(1) See Sheet 370 for applicable exchanges (C)

Advice No. 05-05

Issued June 7, 2005	Effective July 7, 2005
Issued By	CENTURYTEL OF WASHINGTON, INC. d/b/a CenturyTel
	P.O. Box 9901, Vancouver, WA
By	Pamela Donovan
	Title Supervisor, Tariffs

ACCESS SERVICE

16. Rates and Charges (Cont'd) ⁽¹⁾

16.4 Special Access Service (Cont'd)

16.4.3 Special Access Lines

	<u>USOC</u>	<u>Monthly Rate</u>	
(A) Access Line			
Each:			
2-Wire Voice	VGCT2		\$ 36.00
2-Wire INWATS	VG2WI		\$ 36.00
2-Wire OUTWATS	VG2WO		\$ 36.00
4-Wire Voice	VGCT4		\$ 58.00
4-Wire INWATS	VG4WI		\$ 58.00
4-Wire OUTWATS	VG4WO		\$ 58.00
ISDN Repeater	ISDNR		N/A
		Monthly Rates	
	<u>USOC</u>	<u>Fixed</u>	<u>Per Mile</u>
(B) <u>Special Transport</u>			
Per Special Access Service			
Per Month	VGCMT	\$ 24.90	
Per Mile	VGCMF		\$ 1.90
(C) <u>ISDN Transport</u>			
Per Month	ISCMT	N/A	
Per Mile	ISCMF		N/A

(R)

(1) See Sheet 370 for applicable exchanges

Advice No. 06-08, Second Amended

Issued August 23, 2006

Effective September 1, 2006

Issued By CENTURYTEL OF WASHINGTON, INC. d/b/a CenturyTel

P.O. Box 9901, Vancouver, WA

By Pamela Donovan

Title Supervisor, Tariffs

ACCESS SERVICE

16. Rates and Charges (Cont'd) ⁽¹⁾

16.4 Special Access Service (Cont'd)

16.4.3 Special Access Lines (Cont'd)

	<u>USOC</u>	<u>Monthly Rate</u>
(D) <u>Bridging</u>		
<u>Narrow Band</u>		
2 Wire	BCNT2	\$ 5.35
4 Wire	BCNT4	\$11.65
<u>Voice Grade</u>		
2 Wire	BCNV2	\$ 6.00
4 Wire	BCNV4	\$9.50
<u>Data</u>		
2 Wire	BCND2	\$ 6.25
4 Wire	BCND4	\$9.50
Data Capability		\$4.95
(E) <u>Conditioning</u>		
C-Type	X1C	\$20.50
DA-Type	XDC	\$24.85
(F) <u>Improved Return Loss</u>		
2 Wire	1RL2W	\$ 1.59
4 Wire	1RL4W	\$13.94
(G) <u>Signaling Capability</u>		\$12.95
(H) <u>Digital Data Service - Channel Termination</u>		
2.4, 4.8, 9.6, 19.2, DDS		\$58.00
56K		\$58.00
64K		\$63.80
<u>Special Transport</u>		
Per Month		\$24.90
Per Mile		\$1.90
<u>DDS Bridging</u>		\$7.85

(1) See Sheet 370 for applicable exchanges

ACCESS SERVICE

16. Rates and Charges (Cont'd)⁽¹⁾

(C)

16.4 Special Access Service (Cont'd)16.4.3 Special Access Lines (Cont'd)(G) Optional Facility Interface Combinations

	<u>USOC</u>	<u>Monthly Rate</u>
<u>Narrowband</u>		
DB-43 TT (for use with NB4)	9E2	N/A
DB-10 IA (for use with NB5)	9F1	N/A
DB-43 IA (for use with NB5)	9F2	N/A
<u>Voice Grade</u>		
DB DA (for use with VG)	9XQ	N/A
DS AC (for use with VG)	9KV	N/A
DS DA (for use with VG)	9KT	N/A
DS EA (for use with VG)	9K8	N/A
DS LS (for use with VG)	9KX	N/A
DS NO (for use with VG)	9KU	N/A
LS SF (for use with VG)	9YG	N/A
NO DA (for use with VG)	9X2	N/A
NO NO (for use with VG)	9GE	N/A
SF LS (for use with VG)	9MD	N/A
SF EA (for use with VG)	9PO	N/A
SF AC (for use with VG)	9L5	N/A
SF GS (for use with VG)	9PN	N/A

(1) See Sheet 370 for applicable exchanges

(C)

Advice No. 05-05

Issued June 7, 2005

Effective July 7, 2005

Issued By CENTURYTEL OF WASHINGTON, INC. d/b/a CenturyTel
 P.O. Box 9901, Vancouver, WA

By Pamela Donovan Title Supervisor, Tariffs

ACCESS SERVICE

16. Rates and Charges (Cont'd) ⁽¹⁾

16.4 Special Access Service (Cont'd)

16.4.4 High Capacity Service

Regulations concerning High Capacity Service are set forth in 7.10 preceding.

	<u>USOC</u>	<u>Fixed</u>	<u>Monthly Rates Per Mile</u>	
(A) <u>High Capacity Access Line</u>				
DS1 Per High Capacity Access Line				
Per Month	HCEUC	\$ 90.00		
Per Mile	HCEUF		N/A	
 DS3 Pre High Capacity Access Line				
Per Month		\$2,400.00		
Per Mile			N/A	
 (B) <u>High Capacity Transport</u>				
DS1 Per High Capacity Service				
Per Month	VGCMT	\$177.20		(R)
Per Mile	VGCMF		\$ 12.00	
 DS3 Per High Capacity Service				
Per Month		\$500.00		
Per Mile			\$ 225.00	

(1) See Sheet 370 for applicable exchanges

ACCESS SERVICE

16. Rates and Charges (Cont'd) ⁽¹⁾ (C)
 16.4 Special Access Service (Cont'd)
 16.4.4 High Capacity Service (Cont'd)
 (C) Optional Features and Functions

	<u>USOC</u>	<u>Monthly Rate</u>
(1) <u>Multiplexing</u> Per Arrangement		
DS3 to DS1	HCMP3	\$385.00
DS1 to Voice	HCM1V	\$300.00
DS1 to DS0	HCM10	\$300.00

(1) See Sheet 370 for applicable exchanges (C)

Advice No. 05-05

Issued June 7, 2005	Effective July 7, 2005
Issued By	CENTURYTEL OF WASHINGTON, INC. d/b/a CenturyTel
	P.O. Box 9901, Vancouver, WA
By	Pamela Donovan Title Supervisor, Tariffs

ACCESS SERVICE

16. Rates and Charges (Cont'd) ⁽¹⁾ (C)

16.4 Special Access Service (Cont'd)

16.4.4 High Capacity Service (Cont'd)

(C) Optional Features and Functions (Cont'd)

	<u>USOC</u>	<u>Monthly Rate</u>
(2) <u>Automatic Loop Transfer</u> Per arrangement*	HCALT	N/A
(3) <u>Transfer Arrangement</u> (key activated **or Dial-Up ***) Per four port arrangement including control channel termination ****	HCTA	N/A
(E) <u>Network Channel Terminating Equipment (NCTE)</u> Per termination # 1.544 Mbps Automatic Loop Transfer	NCTE NCALT	N/A N/A
(F) <u>Clear Channel Capability</u> Per 1.544 Mbps transmission path	CCCC	N/A

- * An additional Channel Termination charge will apply whenever the spare line is provided as a leg to the customer designated premises.
- ** The key activated control channel is rated as a Metallic Channel Termination and Channel Mileage, if applicable.
- *** The Dial-Up option requires the customer to purchase the Controller Arrangement from 13.3.4 preceding.
- **** An additional Channel Termination charge will apply whenever a spare channel is configured as a leg to the customer designated premises. Additional channel mileage charges will also apply when the transfer arrangement is not located in the customer designated premises serving wire center.
- # NCTE will only be provided under tariff if it existed in the Telephone Company's inventory as of November 18, 1983.
- (1) See Sheet 370 for applicable exchanges (C)

Advice No. 05-05

Issued June 7, 2005	Effective July 7, 2005
Issued By CENTURYTEL OF WASHINGTON, INC. d/b/a CenturyTel	
P.O. Box 9901, Vancouver, WA	
By Pamela Donovan	Title Supervisor, Tariffs

ACCESS SERVICE

16. Rates and Charges (Cont'd) ⁽¹⁾ (C)

16.5 Other Services

16.5.1 Additional Engineering

Regulations concerning Additional Engineering are set forth in Section 13.1 preceding.

<u>Additional Engineering Periods</u>	<u>USOC</u>	<u>Each Half Hour or Fraction Thereof</u>	<u>Tariff Reference</u>
(A) <u>Basic Time</u> Regularly scheduled working hours, Per Engineer	AEHBD	\$37.87	13.1
(B) <u>Overtime</u> Outside of regularly scheduled working hours on a scheduled work day, Per Engineer	AEHOD	\$56.81	13.1
(C) <u>Premium Time</u> Outside of scheduled work day, Per Engineer	AEHPD	\$75.74	13.1

(1) See Sheet 370 for applicable exchanges (C)

Advice No. 05-05

Issued June 7, 2005	Effective July 7, 2005
Issued By	CENTURYTEL OF WASHINGTON, INC. d/b/a CenturyTel
	P.O. Box 9901, Vancouver, WA
By	Pamela Donovan
	Title Supervisor, Tariffs

ACCESS SERVICE

16. Rates and Charges (Cont'd)⁽¹⁾ (C)
 16.5 Other Services (Cont'd)

16.5.2 Additional Labor

Regulations concerning Additional Labor are set forth in Section 13.2 preceding.

<u>Additional Labor Periods</u>	<u>USOC</u>	<u>Each Half Hour or Fraction Thereof</u>	<u>Tariff Reference</u>
(A) <u>Installation or Repair</u>			
<u>Overtime</u>			
Outside of regularly scheduled working hours on a scheduled work day, Per Technician			
	ALHOD	\$41.59	13.2
<u>Premium Time</u>			
Outside of scheduled work day, Per Technician			
	ALHPD	\$55.45	13.2
(B) <u>Standby</u>			
<u>Basic Time</u>			
Regularly scheduled working hours, Per Technician			
	ALTBT	\$27.73	13.2
<u>Overtime</u>			
Outside of regularly scheduled working hours on a scheduled work day, Per Technician			
	ALTOT	\$41.59	13.2
<u>Premium Time</u>			
Outside of scheduled work day, Per Technician			
	ALTPT	\$55.45	13.2

(1) See Sheet 370 for applicable exchanges (C)

Advice No. 05-05

Issued June 7, 2005

Effective July 7, 2005

Issued By CENTURYTEL OF WASHINGTON, INC. d/b/a CenturyTel
 P.O. Box 9901, Vancouver, WA

By Pamela Donovan Title Supervisor, Tariffs

ACCESS SERVICE

16. Rates and Charges (Cont'd) ⁽¹⁾ (C)
 16.5 Other Services (Cont'd)
 16.5.2 Additional Labor (Cont'd)

(C) Testing and Maintenance with other Telephone Companies,
 or Other Labor or NonScheduled Testing

	<u>USOC</u>	Each Half Hour or <u>Fraction Thereof</u>	<u>Tariff Reference</u>
<u>Basic Time</u>			
Regularly scheduled working hours, Per Technician	ALKBT	\$27.73	13.2
<u>Overtime</u>			
Outside of regularly scheduled working hours on a scheduled work day, Per Technician	ALKOT	\$41.59	13.2
<u>Premium Time</u>			
Outside of scheduled work day, Per Technician	ALKPT	\$55.45	13.2

(D) Maintenance of Service

<u>Basic Time</u>			
Regularly scheduled working hours, per technician	MVVBD	\$27.73	
<u>Overtime</u>			
Outside of regularly scheduled working hours on a scheduled work day, -per technician	MVVOD	\$41.59*	
<u>Premium Time</u>			
Outside of scheduled working day, per technician	MVVPD	\$55.45*	

* A call out of a Telephone Company employee at a time not consecutive with the employee's scheduled work period is subject to a minimum charge of four hours.

- (1) See Sheet 370 for applicable exchanges (C)

Advice No. 05-05

Issued June 7, 2005	Effective July 7, 2005
Issued By	CENTURYTEL OF WASHINGTON, INC. d/b/a CenturyTel
	P.O. Box 9901, Vancouver, WA
By	Pamela Donovan Title Supervisor, Tariffs

ACCESS SERVICE

16. Rates and Charges (Cont'd)⁽¹⁾ (C)
 16.5 Other Services (Cont'd)

16.5.3 Miscellaneous Services

Regulations concerning Miscellaneous Services are set forth in Section 13.3 preceding.

(A)	<u>Restoration Priority Charge</u>	<u>USOC</u>	<u>Nonrecurring</u>
	Per service arranged	RSTPR	\$160.00
(B)	<u>IntraLATA Toll Presubscription Charge</u>		Nonrecurring
(1)	IntraLATA Toll Presubscription Change Charge Per Telephone Exchange line or trunk		\$ 5.00#
(2)	Unauthorized IPIC Change Charge		\$25.00
			<u>Rate</u>
(b)	<u>IntraLATA Dialing Parity Rate</u> Originating Intrastate IntraLATA Access Minutes, Per Minute		\$0.000979*
(C)	<u>Provision of Standard Billing Detail USOC Rates and/or Information in magnetic tape format:</u>		
	per record processed	ASBIR	\$.01
	per tape or data file	ASBIF	\$40.00

When a customer simultaneously requests a change to their interLATA carrier and their intraLATA carrier, only the InterLATA change charge as specified in the interstate tariff applies. See Telephone Utilities Exchange Carrier Association ("TUECA") Tariff FCC No. 2.

* A call-out of a Telephone Company employee at a time not consecutive with the employee's scheduled work period is subject to a minimum charge of four hours.

(1) See Sheet 370 for applicable exchanges (C)

Advice No. 05-05

Issued June 7, 2005

Effective July 7, 2005

Issued By CENTURYTEL OF WASHINGTON, INC. d/b/a CenturyTel
 P.O. Box 9901, Vancouver, WA

By Pamela Donovan Title Supervisor, Tariffs

ACCESS SERVICE

16. Rates and Charges (Cont'd) ⁽¹⁾ (C)
 16.5 Other Services (Cont'd)

16.5.4 Special Federal Government Access Services

Regulations concerning Special Federal Government Access Services are as set forth in Section 10, preceding.

(A)	<u>Voice Grade Secure Communications</u>	<u>Monthly Rates</u>	<u>Nonrecurring Charges</u>	<u>Termination Charges</u>
-----	--	----------------------	-----------------------------	----------------------------

Type I, each T-3 Conditioning,	ICB rates and charges apply
-----------------------------------	-----------------------------

Additional Conditioning, per service termination	ICB rates and charges apply
---	-----------------------------

Type II, each G-1 Conditioning,	ICB rates and charges apply
------------------------------------	-----------------------------

Type III, each G-2 Conditioning,	ICB rates and charges apply
-------------------------------------	-----------------------------

Additional Conditioning, per service termination	ICB rates and charges apply
---	-----------------------------

Type IV, each G-3 Conditioning,	ICB rates and charges apply
------------------------------------	-----------------------------

Additional Conditioning, per service termination	ICB rates and charges apply
---	-----------------------------

(B) Wideband Digital Special Access Service

<u>Wideband Secure Communications</u>	<u>Monthly Rates</u>	<u>Nonrecurring Charges</u>	<u>Termination Charges</u>
---------------------------------------	----------------------	-----------------------------	----------------------------

Type I, each	ICB rates and charges apply
--------------	-----------------------------

Type II, each	ICB rates and charges apply
---------------	-----------------------------

Type III, each	ICB rates and charges apply
----------------	-----------------------------

(1) See Sheet 370 for applicable exchanges (C)

Advice No. 05-05

Issued June 7, 2005	Effective July 7, 2005
Issued By	CENTURYTEL OF WASHINGTON, INC. d/b/a CenturyTel
	P.O. Box 9901, Vancouver, WA
By	Pamela Donovan Title Supervisor, Tariffs

ACCESS SERVICE

16. Rates and Charges (Cont'd)⁽¹⁾ (C)

16.5 Other Services (Cont'd)

16.5.5 Special Facilities Routing of Access Services

Regulations concerning Special Facilities Routing of Access Services are as set forth in Section 11, preceding.

(A) Diversity

For each service provided in accordance with 11.1.1 preceding, the rates and charges will be developed on an individual case basis.

(B) Avoidance

For each service provided in accordance with 11.1.2 preceding, the rates and charges will be developed on an individual case basis.

(C) Diversity and Avoidance Combined

For each service provided in accordance with 11.1.1 and 11.1.2 preceding, combined, the rates and charges will be developed on an individual case basis.

(D) Cable-Only Facilities

For each service provided in accordance with 11.1.4 preceding, the rates and charges will be developed on an individual case basis.

(1) See Sheet 370 for applicable exchanges (C)

Advice No. 05-05

Issued June 7, 2005

Effective July 7, 2005

Issued By CENTURYTEL OF WASHINGTON, INC. d/b/a CenturyTel
P.O. Box 9901, Vancouver, WA

By Pamela Donovan Title Supervisor, Tariffs

ACCESS SERVICE

16. Rates and Charges (Cont'd) ⁽¹⁾

(C)

16.5 Other Services (Cont'd)

16.5.6 Specialized Service or Arrangements

Regulations concerning Specialized Service or Arrangements are as set forth in Section 12, preceding.

Rates and Charges for Specialized Service or Arrangements are developed and filed on an individual case basis.

(1) See Sheet 370 for applicable exchanges

(C)

Advice No. 05-05

Issued June 7, 2005

Effective July 7, 2005

Issued By CENTURYTEL OF WASHINGTON, INC. d/b/a CenturyTel
P.O. Box 9901, Vancouver, WA

By Pamela Donovan

Title Supervisor, Tariffs

ACCESS SERVICE

16. Rates and Charges (Cont'd) ⁽¹⁾ (C)

16.5 Other Services (Cont'd)

16.5.7 Billing and Collection

Regulations concerning Billing and Collection are as set forth in Section 8, preceding.

(A) <u>Recording Service</u>	<u>USOC</u>	<u>Rate</u>
(1) <u>Recording</u>		
Per Customer Message	BARRM	\$0.00
Per Special Order	BARRO	\$0.00
(2) <u>Assembling and Editing</u>		
Per Customer Message *, **	BARAM	\$0.00
(3) <u>Provision of Message Detail</u>		
Per Record Processed**	BARAR	\$0.00
Per Tape or Data File**	BARAF	\$0.00
(B) <u>Message Billing Service</u>		
	USOC	Rate
(1) <u>Large Volume Customers</u>		
(over 1.5 million messages annually)		
Message Processing Service		
Per Message	BABTU	\$.08825
(C) <u>Billing Analysis Service</u>		

The rates and charge for Billing Analysis Service are on an Individual Case Basis (ICB).

* Not applicable when Message Processing Service, as set forth in 8.2.1 is provided to the customer except as set forth in 8.2.1(B)(1)(c) and 8.2.1(B)(2)(d).

** This rate is for customers with more than 1.5 million messages annually.

(1) See Sheet 370 for applicable exchanges (C)

Advice No. 05-05

Issued June 7, 2005

Effective July 7, 2005

Issued By CENTURYTEL OF WASHINGTON, INC. d/b/a CenturyTel
 P.O. Box 9901, Vancouver, WA

By Pamela Donovan Title Supervisor, Tariffs

ACCESS SERVICE

16. Rates and Charges (Cont'd) ⁽¹⁾ (C)

16.5 Other Services (Cont'd)

16.5.7 Billing and Collection

(D) <u>Billing Information Service</u>	Rates*				
on	Message Account			Service and Equipment	Detail
	<u>USOC</u>	<u>Detail</u>	<u>Detail</u>	<u>Detail</u>	<u>Tape</u>
(A) <u>CRIS 10 Working Day Information Service</u> , Paper output, per study		ICB	ICB	ICB	
Magnetic tape output, per study	2FSM	ICB	ICB	ICB	
Magnetic tape output, per tape	2FSMT				
ICB					
Fiche output, per study		ICB	ICB	ICB	

* The Quick Turnaround per record charge and the per tape charge is three times the 10 working day per record charge and per tape charge.

(B) <u>DBAS Information Service</u> ,	USOC 1FS++	Rate
Paper output, per record processed		#
Magnetic tape, per record processed		#
per tape or data file		#
Fiche output, per record processed		#
(C) <u>CRIS File or DBAS File Interrogation</u> ,	2FQ++	#
Per request received		

These offerings are only provided where facilities are available. When facilities can be made available with the agreement of the Telephone Company, ICB rates and charges apply.

(1) See Sheet 370 for applicable exchanges (C)

Advice No. 05-05

Issued June 7, 2005	Effective July 7, 2005
Issued By	CENTURYTEL OF WASHINGTON, INC. d/b/a CenturyTel
	P.O. Box 9901, Vancouver, WA
By	Pamela Donovan
	Title Supervisor, Tariffs

WN U-4

CENTURYTEL OF WASHINGTON, INC.

ACCESS SERVICE

16. Rates and Charges (Cont'd)

16.5 Other Services (Cont'd)

16.5.8 Ethernet Service Rates

A. Nonrecurring Charges

- | | | |
|----|--|---|
| 1. | Service Order | See Section 5 |
| 2. | Move Same Building | 50% Ethernet CT
No Service Order Charge |
| 3. | Move Same SWC | New CT NRCs Apply and
Service Order Charge |
| 4. | Move Different SWC | New CT NRCs Apply and
Service Order Charge |
| 5. | Ethernet Channel Terminations
Per Termination | \$760.00 |
| 6. | Ethernet Basic Ports
Per Port | \$190.00 |
| 7. | Interoffice Transport | \$0.00 |

(N)

(N)

Advice No. 08-05

Issued February 22, 2008

Effective March 23, 2008

Issued By CENTURYTEL OF WASHINGTON, INC. d/b/a CenturyTel

P.O. Box 9901, Vancouver, WA

By Chantel Mosby

Title Manager, Tariffs and Compliance

WN U-4

CENTURYTEL OF WASHINGTON, INC.

ACCESS SERVICE

16. Rates and Charges (Cont'd)16.5 Other Services (Cont'd)

16.5.8 Ethernet Service Rates

(N)

B. Recurring Charges

1. Ethernet Channel Terminations

(a) Per termination	
Capacity	<u>1 yr monthly rate</u>
1-3 Mbps	\$180.00
4-6 Mbps	360.00
7-10 Mbps	540.00
11-20 Mbps	1,470.00
21-50 Mbps	2,400.00
51-100 Mbps	3,600.00
101-200 Mbps	4,800.00
201-500 Mbps	7,200.00
501 Mbps - 1 Gbps	9,600.00

2. Ethernet Basic Ports

(a) Per Ethernet Basic Port	
Capacity	<u>1 yr monthly rate</u>
1-3 Mbps	\$242.00
4-6 Mbps	307.00
7-10 Mbps	372.00
11-20 Mbps	437.00
21-50 Mbps	500.00
51-100 Mbps	750.00
101-200 Mbps	1,000.00
201-500 Mbps	1,500.00
501 Mbps - 1 Gbps	2,000.00

(N)

Advice No. 08-05 Supplement A

Issued February 27, 2008

Effective March 23, 2008

Issued By CENTURYTEL OF WASHINGTON, INC. d/b/a CenturyTel
P.O. Box 9901, Vancouver, WA

By Chantel Mosby Title Manager, Tariffs and Compliance

WN U-4

CENTURYTEL OF WASHINGTON, INC.

ACCESS SERVICE

16. Rates and Charges (Cont'd)16.5 Other Services (Cont'd)

16.5.8 Ethernet Service Rates

(N)

B. Recurring Charges (Cont'd)

3. Ethernet Interoffice Transport

(a) Ethernet Interoffice Transport per mile

Capacity	<u>1 yr monthly rate</u>
1-3 Mbps	\$24.00
4-6 Mbps	48.00
7-10 Mbps	72.00
11-20 Mbps	149.00
21-50 Mbps	225.00
51-100 Mbps	338.00
101-200 Mbps	450.00
201-500 Mbps	675.00
501 Mbps - 1 Gbps	900.00

4. Additional Customer Interface Ports

	<u>1 yr monthly rate</u>
(a) Customer Interface Ports (per port)	\$65.00

C. Term Discounts

The following discounts off the 1 year rates apply to 3 and 5 year contract terms:

3 yr	10%
5 yr	20%

(N)

Advice No. 08-05 Supplement A

Issued February 27, 2008

Effective March 23, 2008

Issued By CENTURYTEL OF WASHINGTON, INC. d/b/a CenturyTel
P.O. Box 9901, Vancouver, WA

By Chantel Mosby Title Manager, Tariffs and Compliance

ACCESS SERVICE

16. Rates and Charges (Cont'd)⁽¹⁾ (C)

16.5 Other Services (Cont'd)

16.5.7 Billing and Collection

(D) Billing Information Service

	<u>USOC</u>	<u>Rates</u>
(4) <u>Program Development charge</u> , (applicable to work performed outside the Telephone Company's normal work schedule and/or which requires additions to the work force) Per hour	BAPPD	ICB
(5) <u>Customer Name and Address Information Service</u> , Interrogation, Per request received	CNT++	*
Interrogation confirmation, Per request confirmed	CN6++	*
(6) <u>Marking of Message End User Accounts</u> , Marking, per end user account	BAM++	ICB
Maintenance of mark, Per end user account per month		ICB
(7) <u>Updating of customer data bases or files</u> , Per record transmitted	BAG++	ICB
(8) <u>Provision of Bill Information service</u> , Per Special Order	BAJ++	ICB

* These offerings are only provided where facilities are available. When facilities can be made available with the agreement of the Telephone Company, ICB rates and charges apply.

(1) See Sheet 370 for applicable exchanges (C)

Advice No. 05-05

Issued June 7, 2005	Effective July 7, 2005
Issued By	CENTURYTEL OF WASHINGTON, INC. d/b/a CenturyTel
	P.O. Box 9901, Vancouver, WA
By	Pamela Donovan
	Title Supervisor, Tariffs

ACCESS SERVICE

17.1 Carrier Common Line Access Service⁽¹⁾ (C)
 Regulations, Rates and Charges for Carrier Common Line Access Service are the same as those set forth in WASHINGTON EXCHANGE CARRIER ASSOCIATION Tariff No. WNU-1.

17.2 Access Ordering
 Regulations concerning Access Ordering are set forth in Section 5. preceding.

	<u>USOC</u> <u>Reference</u>	<u>Charge</u>	Tariff
(A) <u>Access Order Charge</u> Per order		N/A	
(B) <u>Service Date Change Charge</u> Per order, per occurrence		\$25.00	5.2.2(A)
(C) <u>Partial Cancellation Charge</u> Per order, per occurrence	See Section 5.2.2(B), preceding		
(D) <u>Design Change Charge</u> Per order, per occurrence		\$25.00	5.2.2(C)
(E) <u>Expedited Order Charge</u> Per order, per occurrence	See Section 5.2.2(D) preceding		
(F) <u>Cancellation of Access Order Charge</u> Per order, per occurrence	See Section 5.2.3 preceding		

(1) See Sheet 398 for applicable CenturyTel of Cowiche, Inc. exchanges (C)

Advice No. 05-05

Issued June 7, 2005	Effective July 7, 2005
Issued By	CENTURYTEL OF WASHINGTON, INC. d/b/a CenturyTel
	P.O. Box 9901, Vancouver, WA
By	Pamela Donovan Title Supervisor, Tariffs

ACCESS SERVICE

17. Rates and Charges (Cont'd) ⁽¹⁾

(C)

17.3 Switched Access Service

Regulations concerning Switched Access are set forth in Section 6 preceding.

17.3.1 Nonrecurring Charges

	<u>USOC</u>	Nonrecurring <u>Charge</u>	<u>Tariff Reference</u>
(A) <u>Local Transport Installation</u> Per Entrance Facility			6.4.1(B)(1)
Voice Grade Four-Wire	NEFT4	\$56.00	
High Capacity DS1	NEFD1	\$400.00	
High Capacity DS3	NEFD3	\$ 750.00	
 (B) <u>Trunk Activation</u> Per 24 Trunks Activated or Fraction thereof on a Per Order basis	 NDTTA	 \$418.00	 6.4.1(B)(1)
 (C) <u>FGC and FGD Trunk Conversion</u> Multifrequency Address Signaling to SS7 Signaling or SS7 Signaling to Multifrequency Address Signaling Per 24 Trunks Converted or Fraction thereof on a Per Order Basis	 SS7TC	 \$210.00	 6.4.1(B)(3)
 (D) <u>Common Channel Signaling Network Connection</u> Per Signaling Entrance Facility			
DS0	NCSEF	\$56.00	
DS1	NC1EF	\$400.00	

(1) See Sheet 398 for applicable CenturyTel of Cowiche, Inc. exchanges

(C)

 Advice No. 05-05

Issued June 7, 2005

Effective July 7, 2005

 Issued By CENTURYTEL OF WASHINGTON, INC. d/b/a CenturyTel
 P.O. Box 9901, Vancouver, WA

By Pamela Donovan Title Supervisor, Tariffs

ACCESS SERVICE

17. Rates and Charges (Cont'd)⁽¹⁾ (C)

17.3 Switched Access Service (Cont'd)

17.3.2 Local Transport

(A) <u>Premium Access</u>	<u>USOC</u>	<u>Monthly Rate</u>	<u>Tariff Reference</u>
(1) <u>Entrance Facility</u> Per Termination			6.1.3(A)(1)
Voice Grade Two-Wire	EFT2	\$65.00	
Voice Grade Four-Wire	EFT4	\$85.00	
High Capacity DS1	EFDS1	\$150.00	
High Capacity DS3	EFDS3	\$2,400.00	
Per Mile, Over 3 Miles			
High Capacity DS1	HCCTPM	N/A	
High Capacity DS3	H3CTPM	N/A	
(2) <u>Direct Trunked Transport</u>			6.1.3(A)(2)
<u>Direct Trunked Facility</u> Per Mile			
Voice Grade	DVCMF	\$1.35	
High Capacity DS1	D1CMF	\$10.66	
High Capacity DS3	D3CMF	\$225.00	
<u>Direct Trunked Termination</u> Per Termination			
Voice Grade	DVCMT	\$40.00	
High Capacity DS1	D1CMT	\$150.00	
High Capacity DS3	D3CMT	\$500.00	

(1) See Sheet 398 for applicable CenturyTel of Cowiche, Inc. exchanges (C)

Advice No. 05-05

Issued June 7, 2005	Effective July 7, 2005
Issued By	CENTURYTEL OF WASHINGTON, INC. d/b/a CenturyTel
	P.O. Box 9901, Vancouver, WA
By	Pamela Donovan Title Supervisor, Tariffs

ACCESS SERVICE

17. Rates and Charges (Cont'd) ⁽¹⁾ (C)

17.3 Switched Access Service Cont'd)

17.3.2 Local Transport (Cont'd)

(A) <u>Premium Access</u> (Cont'd)	<u>USOC</u>	<u>Monthly Rate</u>	<u>Tariff Reference</u>
(3) <u>Tandem Switched Transport</u>			6.1.3(A)(3)
<u>Tandem Switched Facility</u> Per Access Minute Per Mile	LTF	\$0.000120	
<u>Tandem Switched Termination</u> Per Access Minute Per Termination	LTT	\$0.001690	
<u>Tandem Switching</u> Per Access Minute Per Tandem	LTTAN	\$0.004579	
 (B) <u>Non-Premium Access</u>			
<u>Tandem Switched Facility</u> Per Access Minute Per Mile	LTF	\$0.000100	
<u>Tandem Switched Termination</u> Per Access Minute Per Termination	LTT	\$0.001405	
<u>Tandem Switching</u> Per Access Minute Per Tandem	LTTAN	\$0.004579	
 (C) <u>Multiplexing</u>			6.1.3(A)(5)
Per Arrangement DS3 to DS1	MUX31	\$385.00	
DS1 to Voice	MUX10	\$300.00	
DS1 to DS0	MUX10	\$300.00	

(1) See Sheet 398 for applicable CenturyTel of Cowiche, Inc. exchanges (C)

Advice No. 05-05

Issued June 7, 2005	Effective July 7, 2005
Issued By CENTURYTEL OF WASHINGTON, INC. d/b/a CenturyTel	
P.O. Box 9901, Vancouver, WA	
By Pamela Donovan	Title Supervisor, Tariffs

ACCESS SERVICE

17. Rates and Charges (Cont'd)⁽¹⁾ (C)

17.3 Switched Access Service Cont'd)

17.3.2 Local Transport (Cont'd)

	<u>USOC</u>	<u>Monthly Rate</u>	<u>Tariff Reference</u>
(D) <u>Common Channel Signaling Network Connection</u>			
(1) <u>Signaling Network Access Link</u>			6.10.3
<u>Signaling Mileage Facility</u>			
Per Mile			
DS0	CCCMF	\$1.35	
DS1	C1CMF	\$10.66	
<u>Signaling Mileage Termination</u>			
Per Termination			
DS0	CCCMT	\$40.00	
DS1	C1CMT	\$150.00	
<u>Signaling Entrance Facility</u>			
Per Facility			
DS0	CCSEF	\$85.00	
DS1	C1SEF	\$150.00	
Per Mile, Over 3 Miles			
DS1	CSEFPM	\$65.00	
(2) <u>STP Port</u>			
Per Port	STPPT	\$900.00	

(1) See Sheet 398 for applicable CenturyTel of Cowiche, Inc. exchanges (C)

Advice No. 05-05

Issued June 7, 2005

Effective July 7, 2005

Issued By CENTURYTEL OF WASHINGTON, INC. d/b/a CenturyTel
 P.O. Box 9901, Vancouver, WA

By Pamela Donovan Title Supervisor, Tariffs

ACCESS SERVICE

17. Rates and Charges (Cont'd)⁽¹⁾ (C)

17.3 Switched Access Service (Cont'd)

17.3.2 Local Transport (Cont'd)

	USOC	Monthly Rate	Tariff Reference
(E) <u>Network Blocking</u> (Applies to FGD only) Per Blocked Call	NBCPC	\$0.0076	6.7.9
(F) <u>800 Data Base Access Service Queries</u> Per Query			6.10.3
Basic	800B	\$0.011770	
Vertical Feature	800V	\$0.011770	

(1) See Sheet 398 for applicable CenturyTel of Cowiche, Inc. exchanges (C)

Advice No. 05-05

Issued June 7, 2005	Effective July 7, 2005
Issued By	CENTURYTEL OF WASHINGTON, INC. d/b/a CenturyTel
	P.O. Box 9901, Vancouver, WA
By	Pamela Donovan
	Title Supervisor, Tariffs

ACCESS SERVICE

17. Rates and Charges (Cont'd) ⁽¹⁾

17.3 Switched Access Service (Cont'd)

17.3.3 End Office

(A) <u>Local Switching</u>	(D) <u>Monthly Rate</u>	<u>Tariff Reference</u>
(1) <u>Premium</u>		
Local Switching 1 – Originating Per Access Minute	\$0.112755	
Local Switching 2 – Terminating Per Access Minute	\$0.007148	
(2) <u>Non-Premium</u>		
Originating Per Access Minute	\$0.112755	
Terminating Per Access Minute	\$0.007148	
(B) <u>Line Terminations</u>		
(1) <u>Access Line Termination</u>		
Premium	N/A	
Transitional	N/A	
(C) <u>Intercept Intercept Charge</u>		
Premium	N/A	
Transitional	(D) N/A	
(D) <u>Interim USF Additive</u>		
Per Terminating Access Minute	\$0.076684	
(E) <u>Reserved For Future Use</u>		(C) (D) (D)

⁽¹⁾ See Sheet 398 for applicable CenturyTel of Cowiche, Inc. exchanges

ACCESS SERVICE

17. Rates and Charges (Cont'd) ⁽¹⁾

(C)

17.4 Special Access Service

Regulations concerning Special Access Service are set forth in Section 7 preceding.

17.4.1 Nonrecurring Charges(A) Special Access Line

(1) <u>Installation</u>	<u>USOC</u>	Nonrecurring <u>Charge</u>	<u>Tariff Reference</u>
2 Wire		\$223.24	
4 Wire		\$223.24	
ISDN Repeater		N/A	
(2) <u>Multiplexing</u>			
Voice to Narrowband Per Arrangement	NMQX	\$ 72.00	
DS1 to Voice Per Arrangement	NMXDS	\$203.00	
(3) <u>Optional Facility Interface Combinations</u>			
<u>Narrowband</u>			
DB-43 TT (for use with NB4)	N9E2	\$ 38.00	
DB-10 IA (for use with NB5)	N9F1	\$ 38.00	
DB-43 IA (for use with NB5)	N9F2	\$ 38.00	

(1) See Sheet 398 for applicable CenturyTel of Cowiche, Inc. exchanges

(C)

Advice No. 05-05

Issued June 7, 2005

Effective July 7, 2005

Issued By CENTURYTEL OF WASHINGTON, INC. d/b/a CenturyTel
 P.O. Box 9901, Vancouver, WA

By Pamela Donovan Title Supervisor, Tariffs

ACCESS SERVICE

17. Rates and Charges (Cont'd)⁽¹⁾ (C)

17.4 Special Access Service
 Regulations concerning Special Access Service are set forth in Section 7 preceding.

17.4.1 Nonrecurring Charges

(A) Special Access Line

(3) Optional Facility Interface Combinations (Cont'd)

<u>Voice Grade</u>	<u>USOC</u>	<u>Nonrecurring Charge</u>	<u>Tariff Reference</u>
DB DA (for use with VG)	N9XQ	\$ 38.00	
DS AC (for use with VG)	N9KV	\$ 50.00	
DS DA (for use with VG)	N9KT	\$ 38.00	
DS EA (for use with VG)	N9K8	\$ 38.00	
DS LS (for use with VG)	N9KX	\$ 38.00	
DS NO (for use with VG)	N9KU	\$ 38.00	
LS SF (for use with VG)	N9YG	\$ 44.00	
NO DA (for use with VG)	N9X2	\$ 38.00	
NO NO (for use with VG)	N9GE	\$ 38.00	
SF LS (for use with VG)	N9MD	\$ 50.00	
SF EA (for use with VG)	N9PO	\$ 50.00	
SF AC (for use with VG)	N9L5	\$ 50.00	
SF GS (for use with VG)	N9PN	\$ 50.00	

(1) See Sheet 398 for applicable CenturyTel of Cowiche, Inc. exchanges (C)

Advice No. 05-05

Issued June 7, 2005

Effective July 7, 2005

Issued By CENTURYTEL OF WASHINGTON, INC. d/b/a CenturyTel
 P.O. Box 9901, Vancouver, WA

By Pamela Donovan Title Supervisor, Tariffs

ACCESS SERVICE

17. Rates and Charges (Cont'd)⁽¹⁾ (C)

17.4 Special Access Service (Cont'd)

17.4.1 Nonrecurring Charges(Cont'd)

(A) Special Access Line

	<u>USOC</u>	<u>Nonrecurring Charge</u>	<u>Tariff Reference</u>
(4) <u>Bridging</u>			
(a) Narrowband Bridges			
Telegraph Bridging (available with NB4 & NB5)			
2 Wire	BCNT2	\$ 12.00	
4 Wire	BCNT4	\$ 18.00	
(b) Voice Grade Bridges			
Voice Bridging (available with VG)			
2 Wire	BCNV2	\$ 12.00	
4 Wire	BCNV4	\$ 18.00	
Data Bridging (available with VG)			
2 Wire	BCND2	\$ 12.00	
4 Wire	BCND4	\$ 18.00	
(5) <u>Conditioning</u>			
C-Type	NX1C	\$184.00	
DA Type	NXDC	\$184.00	
(6) <u>Improved Return Loss</u>			
2 Wire	NRL2W	\$ 37.00	
4 Wire	NRL4W	\$ 74.00	

(1) See Sheet 398 for applicable CenturyTel of Cowiche, Inc. exchanges (C)

Advice No. 05-05

Issued June 7, 2005

Effective July 7, 2005

Issued By CENTURYTEL OF WASHINGTON, INC. d/b/a CenturyTel
 P.O. Box 9901, Vancouver, WA

By Pamela Donovan Title Supervisor, Tariffs

ACCESS SERVICE

17. Rates and Charges (Cont'd) ⁽¹⁾ (C)

17.4 Special Access Service (Cont'd)

17.4.1 Nonrecurring Charges (Cont'd)

(B) High Capacity Access Service

<u>USOC</u>	<u>Monthly Rate</u>	<u>Tariff Reference</u>
-------------	---------------------	-------------------------

(1) Installation

- | | | |
|-------------------------------|-------|----------|
| (a) High Capacity Access Line | NCEUC | \$ 94.00 |
| (b) High Capacity Transport | NCSTB | \$418.00 |

17.4.2 Surcharge for Special Access Service

<u>USOC</u>	<u>Monthly Rate</u>	<u>Tariff Reference</u>
-------------	---------------------	-------------------------

<u>Special Access Surcharge</u> Per Voice Grade Equivalent	\$0.00	7.4.2
---	--------	-------

(1) See Sheet 398 for applicable CenturyTel of Cowiche, Inc. exchanges (C)

Advice No. 05-05

Issued June 7, 2005	Effective July 7, 2005
Issued By CENTURYTEL OF WASHINGTON, INC. d/b/a CenturyTel	
P.O. Box 9901, Vancouver, WA	
By Pamela Donovan	Title Supervisor, Tariffs

ACCESS SERVICE

17. Rates and Charges (Cont'd) ⁽¹⁾

17.4 Special Access Service (Cont'd)

17.4.3 Special Access Lines

	<u>USOC</u>	<u>Monthly Rate</u>		
(A) Access Line				
Each:				
2-Wire Voice	VGCT2		\$ 65.00	
2-Wire INWATS	VG2WI		\$ 65.00	
2-Wire OUTWATS	VG2WO		\$ 65.00	
4-Wire Voice	VGCT4		\$ 85.00	
4-Wire INWATS	VG4WI		\$ 85.00	
4-Wire OUTWATS	VG4WO		\$ 85.00	
ISDN Repeater	ISDNR		N/A	
		Monthly Rates		
	<u>USOC</u>	<u>Fixed</u>	<u>Per Mile</u>	
(B) <u>Special Transport</u>				
Per Special Access Service				
Per Month	VGCMT	\$ 24.90		
Per Mile	VGCMF		\$ 3.00	(R)
(C) <u>ISDN Transport</u>				
Per Month	ISCMT	N/A		
Per Mile	ISCMF		N/A	

(1) See Sheet 398 for applicable CenturyTel of Cowiche, Inc. exchanges

Advice No. 06-08, Second Amended

Issued August 23, 2006

Effective September 1, 2006

Issued By CENTURYTEL OF WASHINGTON, INC. d/b/a CenturyTel
 P.O. Box 9901, Vancouver, WA

By Pamela Donovan Title Supervisor, Tariffs

ACCESS SERVICE

17. Rates and Charges (Cont'd) ⁽¹⁾

17.4 Special Access Service (Cont'd)

17.4.3 Special Access Lines (Cont'd)

	<u>USOC</u>	<u>Monthly Rate</u>	
(D) <u>Bridging</u>			
<u>Narrow Band</u>			
2 Wire	BCNT2	\$ 5.35	
4 Wire	BCNT4	\$11.65	
<u>Voice Grade</u>			
2 Wire	BCNV2	\$ 6.00	
4 Wire	BCNV4	\$ 9.50	
<u>Data</u>			
2 Wire	BCND2	\$ 6.00	
4 Wire	BCND4	\$ 9.50	
<u>Data Capability</u>		\$4.95	
(E) <u>Conditioning</u>			
C-Type	X1C	\$ 20.50	
DA-Type	XDC	\$24.85	
(F) <u>Improved Return Loss</u>			
2 Wire	1RL2W	\$ 1.59	
4 Wire	1RL4W	\$13.94	
(G) <u>Signaling Capability</u>		\$12.95	
(H) <u>Digital Data Service - Channel Termination</u>			
2.4, 2.8, 9.6, 19.2,56K, 64K		\$85.00	
<u>Special Transport</u>			
Per Month		\$24.90	(R)
Per Mile		\$3.00	
<u>DDS Bridging</u>		\$7.85	

(1) See Sheet 398 for applicable CenturyTel of Cowiche, Inc. exchanges

Advice No. 06-08, Second Amended

Issued August 23, 2006

Effective September 1, 2006

Issued By CENTURYTEL OF WASHINGTON, INC. d/b/a CenturyTel

P.O. Box 9901, Vancouver, WA

By Pamela Donovan

Title Supervisor, Tariffs

ACCESS SERVICE

17. Rates and Charges (Cont'd)⁽¹⁾

(C)

17.4 Special Access Service (Cont'd)17.4.3 Special Access Lines (Cont'd)(G) Optional Facility Interface Combinations

	<u>USOC</u>	<u>Monthly Rate</u>
<u>Narrowband</u>		
DB-43 TT (for use with NB4)	9E2	N/A
DB-10 IA (for use with NB5)	9F1	N/A
DB-43 IA (for use with NB5)	9F2	N/A
<u>Voice Grade</u>		
DB DA (for use with VG)	9XQ	N/A
DS AC (for use with VG)	9KV	N/A
DS DA (for use with VG)	9KT	N/A
DS EA (for use with VG)	9K8	N/A
DS LS (for use with VG)	9KX	N/A
DS NO (for use with VG)	9KU	N/A
LS SF (for use with VG)	9YG	N/A
NO DA (for use with VG)	9X2	N/A
NO NO (for use with VG)	9GE	N/A
SF LS (for use with VG)	9MD	N/A
SF EA (for use with VG)	9PO	N/A
SF AC (for use with VG)	9L5	N/A
SF GS (for use with VG)	9PN	N/A

(1) See Sheet 398 for applicable CenturyTel of Cowiche, Inc. exchanges

(C)

Advice No. 05-05

Issued June 7, 2005

Effective July 7, 2005

Issued By CENTURYTEL OF WASHINGTON, INC. d/b/a CenturyTel
 P.O. Box 9901, Vancouver, WA

By Pamela Donovan Title Supervisor, Tariffs

ACCESS SERVICE

17. Rates and Charges (Cont'd) ⁽¹⁾

17.4 Special Access Service (Cont'd)

17.4.4 High Capacity Service

Regulations concerning High Capacity Service are set forth in 7.10 preceding.

	<u>USOC</u>	<u>Fixed</u>	<u>Monthly Rates Per Mile</u>	
(A) <u>High Capacity Access Line</u>				
DS1 Per High Capacity Access Line				
Per Month	HCEUC	\$ 85.00		
Per Mile	HCEUF		N/A	
DS3 Per High Capacity Access Line				
Per Month		\$ 2,400.00		
Per Mile			N/A	
(B) <u>High Capacity Transport</u>				
DS1 Per High Capacity Service				
Per Month	VGCMT	\$177.20		(R)
Per Mile	VGCMF		\$ 12.00	
DS3 Per High Capacity Service				
Per Month	VGCMT	\$500.00		
Per Mile	VGCMF		\$ 225.00	

(1) See Sheet 398 for applicable CenturyTel of Cowiche, Inc. exchanges

Advice No. 06-08, Second Amended

Issued August 23, 2006

Effective September 1, 2006

Issued By CENTURYTEL OF WASHINGTON, INC. d/b/a CenturyTel
 P.O. Box 9901, Vancouver, WA

By Pamela Donovan Title Supervisor, Tariffs

ACCESS SERVICE

17. Rates and Charges (Cont'd)⁽¹⁾

(C)

17.4 Special Access Service (Cont'd)

17.4.4 High Capacity Service (Cont'd)

(C) Optional Features and Functions

	<u>USOC</u>	<u>Monthly Rate</u>
(1) <u>Multiplexing</u> Per Arrangement		
DS3 to DS1	HCMP3	\$385.00
DS1 to Voice	HCM1V	\$300.00
DS1 to DS0	HCM10	\$300.00

(1) See Sheet 398 for applicable CenturyTel of Cowiche, Inc. exchanges

(C)

Advice No. 05-05

Issued June 7, 2005

Effective July 7, 2005

Issued By CENTURYTEL OF WASHINGTON, INC. d/b/a CenturyTel
 P.O. Box 9901, Vancouver, WA

By Pamela Donovan Title Supervisor, Tariffs

ACCESS SERVICE

17. Rates and Charges (Cont'd)⁽¹⁾

(C)

17.4 Special Access Service (Cont'd)

17.4.4 High Capacity Service (Cont'd)

(C) Optional Features and Functions (Cont'd)

	<u>USOC</u>	<u>Monthly Rate</u>
(2) <u>Automatic Loop Transfer</u> Per arrangement*	HCALT	N/A
(3) <u>Transfer Arrangement</u> (key activated **or Dial-Up ***) Per four port arrangement including control channel termination ****	HCTA	N/A
(E) <u>Network Channel Terminating Equipment (NCTE)</u> Per termination # 1.544 Mbps Automatic Loop Transfer	NCTE NCALT	N/A N/A
(F) <u>Clear Channel Capability</u> Per 1.544 Mbps transmission path	CCCC	N/A

* An additional Channel Termination charge will apply whenever the spare line is provided as a leg to the customer designated premises.

** The key activated control channel is rated as a Metallic Channel Termination and Channel Mileage, if applicable.

*** The Dial-Up option requires the customer to purchase the Controller Arrangement from 13.3.4 preceding.

**** An additional Channel Termination charge will apply whenever a spare channel is configured as a leg to the customer designated premises. Additional channel mileage charges will also apply when the transfer arrangement is not located in the customer designated premises serving wire center.

NCTE will only be provided under tariff if it existed in the Telephone Company's inventory as of November 18, 1983.

(1) See Sheet 398 for applicable CenturyTel of Cowiche, Inc. exchanges

(C)

Advice No. 05-05

Issued June 7, 2005

Effective July 7, 2005

Issued By CENTURYTEL OF WASHINGTON, INC. d/b/a CenturyTel
 P.O. Box 9901, Vancouver, WA

By Pamela Donovan

Title Supervisor, Tariffs

ACCESS SERVICE

17. Rates and Charges (Cont'd) ⁽¹⁾

(C)

17.5 Other Services

17.5.1 Additional Engineering

Regulations concerning Additional Engineering are set forth in Section 13.1 preceding.

<u>Additional Engineering Periods</u>	<u>USOC</u>	<u>Each Half Hour or Fraction Thereof</u>	<u>Tariff Reference</u>
(A) <u>Basic Time</u> Regularly scheduled working hours, Per Engineer	AEHBD	\$37.87	13.1
(B) <u>Overtime</u> Outside of regularly scheduled working hours on a scheduled work day, Per Engineer	AEHOD	\$56.81	13.1
(C) <u>Premium Time</u> Outside of scheduled work day, Per Engineer	AEHPD	\$75.74	13.1

(1) See Sheet 398 for applicable CenturyTel of Cowiche, Inc. exchanges

(C)

Advice No. 05-05

Issued June 7, 2005	Effective July 7, 2005
Issued By	CENTURYTEL OF WASHINGTON, INC. d/b/a CenturyTel
	P.O. Box 9901, Vancouver, WA
By	Pamela Donovan Title Supervisor, Tariffs

ACCESS SERVICE

17. Rates and Charges (Cont'd) ⁽¹⁾ (C)

17.5 Other Services (Cont'd)

17.5.2 Additional Labor

Regulations concerning Additional Labor are set forth in Section 13.2 preceding.

<u>Additional Labor Periods</u>	<u>USOC</u>	<u>Each Half Hour or Fraction Thereof</u>	<u>Tariff Reference</u>
 (A) <u>Installation or Repair</u>			
<u>Overtime</u>			
Outside of regularly scheduled working hours on a scheduled work day, Per Technician			
ALHOD	\$41.59		13.2
 <u>Premium Time</u>			
Outside of scheduled work day, Per Technician			
ALHPD	\$55.45		13.2
 (B) <u>Standby</u>			
<u>Basic Time</u>			
Regularly scheduled working hours, Per Technician			
ALTBT	\$27.73		13.2
 <u>Overtime</u>			
Outside of regularly scheduled working hours on a scheduled work day, Per Technician			
ALTOT	\$41.59		13.2
 <u>Premium Time</u>			
Outside of scheduled work day, Per Technician			
ALTPT	\$55.45		13.2

(1) See Sheet 398 for applicable CenturyTel of Cowiche, Inc. exchanges (C)

Advice No. 05-05

Issued June 7, 2005

Effective July 7, 2005

Issued By CENTURYTEL OF WASHINGTON, INC. d/b/a CenturyTel
 P.O. Box 9901, Vancouver, WA

By Pamela Donovan Title Supervisor, Tariffs

ACCESS SERVICE

17. Rates and Charges (Cont'd) ⁽¹⁾ (C)

17.5 Other Services (Cont'd)

17.5.2 Additional Labor (Cont'd)

(C) Testing and Maintenance with other Telephone Companies, or Other Labor or NonScheduled Testing

	<u>USOC</u>	<u>Each Half Hour or Fraction Thereof</u>	<u>Tariff Reference</u>
<u>Basic Time</u> Regularly scheduled working hours, Per Technician	ALKBT	\$27.73	13.2
<u>Overtime</u> Outside of regularly scheduled working hours on a scheduled work day, Per Technician	ALKOT	\$41.59	13.2
<u>Premium Time</u> Outside of scheduled work day, Per Technician	ALKPT	\$55.45	13.2

(D) Maintenance of Service

<u>Basic Time</u> Regularly scheduled working hours, per technician	MVBBD	\$27.73	
<u>Overtime</u> Outside of regularly scheduled working hours on a scheduled work day, -per technician	MVVOD	\$41.59*	
<u>Premium Time</u> Outside of scheduled working day, per technician	MVPDP	\$55.45*	

* A call out of a Telephone Company employee at a time not consecutive with the employee's scheduled work period is subject to a minimum charge of four hours.

(1) See Sheet 398 for applicable CenturyTel of Cowiche, Inc. exchanges (C)

Advice No. 05-05

Issued June 7, 2005	Effective July 7, 2005
Issued By	CENTURYTEL OF WASHINGTON, INC. d/b/a CenturyTel
	P.O. Box 9901, Vancouver, WA
By	Pamela Donovan Title Supervisor, Tariffs

ACCESS SERVICE

17. Rates and Charges (Cont'd) ⁽¹⁾ (C)

17.5 Other Services (Cont'd)

17.5.3 Miscellaneous Services

Regulations concerning Miscellaneous Services are set forth in Section 13.3 preceding.

<u>(A) Restoration Priority Charge</u>	<u>USOC</u>	<u>Nonrecurring</u>
Per service arranged	RSTPR	\$160.00
<u>(B) IntraLATA Toll Presubscription Charge</u>		<u>Nonrecurring</u>
(1) IntraLATA Toll Presubscription Change Charge Per Telephone Exchange line or trunk		\$ 5.00#
(2) Unauthorized IPIC Change Charge		\$25.00
		<u>Rate</u>
(b) <u>IntraLATA Dialing Parity Rate</u> Originating Intrastate IntraLATA Access Minutes, Per Minute		\$0.007662*
<u>(C) Provision of Standard Billing Detail USOC Rates and/or Information in magnetic tape format:</u>		
per record processed	ASBIR	\$.01
per tape or data file	ASBIF	\$40.00

When a customer simultaneously requests a change to their interLATA carrier and their intraLATA carrier, only the InterLATA change charge as specified in the interstate tariff applies. See Telephone Utilities Exchange Carrier Association ("TUECA") Tariff FCC No. 2.

* A call-out of a Telephone Company employee at a time not consecutive with the employee's scheduled work period is subject to a minimum charge of four hours.

(1) See Sheet 398 for applicable CenturyTel of Cowiche, Inc. exchanges (C)

Advice No. 05-05

Issued June 7, 2005

Effective July 7, 2005

Issued By CENTURYTEL OF WASHINGTON, INC. d/b/a CenturyTel
 P.O. Box 9901, Vancouver, WA

By Pamela Donovan Title Supervisor, Tariffs

ACCESS SERVICE

17. Rates and Charges (Cont'd) ⁽¹⁾

(C)

17.5 Other Services (Cont'd)

17.5.4 Special Federal Government Access Services

Regulations concerning Special Federal Government Access Services are as set forth in Section 10, preceding.

(A) <u>Voice Grade Secure Communications</u>	<u>Monthly Rates</u>	<u>Nonrecurring Charges</u>	<u>Termination Charges</u>
Type I, each T-3 Conditioning,	ICB rates and charges apply		
Additional Conditioning, per service termination	ICB rates and charges apply		
Type II, each G-1 Conditioning,	ICB rates and charges apply		
Type III, each G-2 Conditioning,	ICB rates and charges apply		
Additional Conditioning, per service termination	ICB rates and charges apply		
Type IV, each G-3 Conditioning,	ICB rates and charges apply		
Additional Conditioning, per service termination	ICB rates and charges apply		

(B) Wideband Digital Special Access Service

<u>Wideband Secure Communications</u>	<u>Monthly Rates</u>	<u>Nonrecurring Charges</u>	<u>Termination Charges</u>
Type I, each	ICB rates and charges apply		
Type II, each	ICB rates and charges apply		
Type III, each	ICB rates and charges apply		

(1) See Sheet 398 for applicable CenturyTel of Cowiche, Inc. exchanges

(C)

Advice No. 05-05

Issued June 7, 2005	Effective July 7, 2005
Issued By	CENTURYTEL OF WASHINGTON, INC. d/b/a CenturyTel
	P.O. Box 9901, Vancouver, WA
By	Pamela Donovan Title Supervisor, Tariffs

ACCESS SERVICE

17. Rates and Charges (Cont'd)⁽¹⁾

(C)

17.5 Other Services (Cont'd)

17.5.5 Special Facilities Routing of Access Services

Regulations concerning Special Facilities Routing of Access Services are as set forth in Section 11, preceding.

(A) Diversity

For each service provided in accordance with 11.1.1 preceding, the rates and charges will be developed on an individual case basis.

(B) Avoidance

For each service provided in accordance with 11.1.2 preceding, the rates and charges will be developed on an individual case basis.

(C) Diversity and Avoidance Combined

For each service provided in accordance with 11.1.1 and 11.1.2 preceding, combined, the rates and charges will be developed on an individual case basis.

(D) Cable-Only Facilities

For each service provided in accordance with 11.1.4 preceding, the rates and charges will be developed on an individual case basis.

(1) See Sheet 398 for applicable CenturyTel of Cowiche, Inc. exchanges

(C)

Advice No. 05-05

Issued June 7, 2005

Effective July 7, 2005

Issued By CENTURYTEL OF WASHINGTON, INC. d/b/a CenturyTel
P.O. Box 9901, Vancouver, WA

By Pamela Donovan

Title Supervisor, Tariffs

ACCESS SERVICE

17. Rates and Charges (Cont'd)⁽¹⁾ (C)

17.5 Other Services (Cont'd)

17.5.7 Billing and Collection

Regulations concerning Billing and Collection are as set forth in Section 8, preceding.

(A) <u>Recording Service</u>	<u>USOC</u>	<u>Rate</u>
(1) <u>Recording</u>		
Per Customer Message	BARRM	\$0.00
Per Special Order	BARRO	\$0.00
(2) <u>Assembling and Editing</u>		
Per Customer Message *, **	BARAM	\$0.00
(3) <u>Provision of Message Detail</u>		
Per Record Processed**	BARAR	\$0.00
Per Tape or Data File**	BARAF	\$0.00
(B) <u>Message Billing Service</u>		
	USOC	Rate
(1) <u>Large Volume Customers</u>		
(over 1.5 million messages annually)		
Message Processing Service		
Per Message	BABTU	\$.08825
(C) <u>Billing Analysis Service</u>		

The rates and charge for Billing Analysis Service are on an Individual Case Basis (ICB).

* Not applicable when Message Processing Service, as set forth in 8.2.1 is provided to the customer except as set forth in 8.2.1(B)(1)(c) and 8.2.1(B)(2)(d).

** This rate is for customers with more than 1.5 million messages annually.

(1) See Sheet 398 for applicable CenturyTel of Cowiche, Inc. exchanges (C)

Advice No. 05-05

Issued June 7, 2005

Effective July 7, 2005

Issued By CENTURYTEL OF WASHINGTON, INC. d/b/a CenturyTel

P.O. Box 9901, Vancouver, WA

By Pamela Donovan

Title Supervisor, Tariffs

ACCESS SERVICE

17. Rates and Charges (Cont'd)⁽¹⁾ (C)

17.5 Other Services (Cont'd)

17.5.7 Billing and Collection

(D) <u>Billing Information Service</u>	Rates*				
	<u>USOC</u>	<u>Message Detail</u>	<u>Account Detail</u>	<u>Service and Equipment Detail</u>	<u>Detail on Tape</u>
(A) <u>CRIS 10 Working Day Information Service</u> , Paper output, per study		ICB	ICB	ICB	
Magnetic tape output, per study	2FSM	ICB	ICB	ICB	
Magnetic tape output, per tape ICB	2FSMT				
Fiche output, per study		ICB	ICB	ICB	

* The Quick Turnaround per record charge and the per tape charge is three times the 10 working day per record charge and per tape charge.

(B) <u>DBAS Information Service</u> ,	<u>USOC</u> 1FS++	<u>Rate</u>
Paper output, per record processed		#
Magnetic tape, per record processed		#
per tape or data file		#
Fiche output, per record processed		#
(C) <u>CRIS File or DBAS File Interrogation</u> , Per request received	2FQ++	#

These offerings are only provided where facilities are available. When facilities can be made available with the agreement of the Telephone Company, ICB rates and charges apply.

(1) See Sheet 398 for applicable CenturyTel of Cowiche, Inc. exchanges (C)

Advice No. 05-05

Issued June 7, 2005	Effective July 7, 2005
Issued By	CENTURYTEL OF WASHINGTON, INC. d/b/a CenturyTel
	P.O. Box 9901, Vancouver, WA
By	Pamela Donovan
	Title Supervisor, Tariffs

ACCESS SERVICE

17. Rates and Charges (Cont'd) ⁽¹⁾

(C)

17.5 Other Services (Cont'd)17.5.7 Billing and Collection(D) Billing Information Service

	<u>USOC</u>	<u>Rates</u>
(4) <u>Program Development charge</u> , (applicable to work performed outside the Telephone Company's normal work schedule and/or which requires additions to the work force) Per hour	BAPPD	ICB
(5) <u>Customer Name and Address Information Service</u> , Interrogation, Per request received	CNT++	*
Interrogation confirmation, Per request confirmed	CN6++	*
(6) <u>Marking of Message End User Accounts</u> , Marking, per end user account	BAM++	ICB
Maintenance of mark, Per end user account per month		ICB
(7) <u>Updating of customer data bases or files</u> , Per record transmitted	BAG++	ICB
(8) <u>Provision of Bill Information service</u> , Per Special Order	BAJ++	ICB

* These offerings are only provided where facilities are available. When facilities can be made available with the agreement of the Telephone Company, ICB rates and charges apply.

(1) See Sheet 398 for applicable CenturyTel of Cowiche, Inc. exchanges

(C)

Advice No. 05-05

Issued June 7, 2005

Effective July 7, 2005

Issued By CENTURYTEL OF WASHINGTON, INC. d/b/a CenturyTel
 P.O. Box 9901, Vancouver, WA

By Pamela Donovan

Title Supervisor, Tariffs

WN U-4

CENTURYTEL OF WASHINGTON, INC.

ACCESS SERVICE

17. Rates and Charges (Cont'd)

17.5 Other Services (Cont'd)

17.5.8 Ethernet Service Rates

A. Nonrecurring Charges

- | | | |
|----|--|---|
| 1. | Service Order | See Section 5 |
| 2. | Move Same Building | 50% Ethernet CT
No Service Order Charge |
| 3. | Move Same SWC | New CT NRCs Apply and
Service Order Charge |
| 4. | Move Different SWC | New CT NRCs Apply and
Service Order Charge |
| 5. | Ethernet Channel Terminations
Per Termination | \$760.00 |
| 6. | Ethernet Basic Ports
Per Port | \$190.00 |
| 7. | Interoffice Transport | \$0.00 |

(N)

(N)

Advice No. 08-05

Issued February 22, 2008

Effective March 23, 2008

Issued By CENTURYTEL OF WASHINGTON, INC. d/b/a CenturyTel

P.O. Box 9901, Vancouver, WA

By Chantel Mosby

Title Manager, Tariffs and Compliance

WN U-4

CENTURYTEL OF WASHINGTON, INC.

ACCESS SERVICE

17. Rates and Charges (Cont'd)17.5 Other Services (Cont'd)

17.5.8 Ethernet Service Rates

(N)

B. Recurring Charges

1. Ethernet Channel Terminations

(a) Per termination	
Capacity	<u>1 yr monthly rate</u>
1-3 Mbps	\$180.00
4-6 Mbps	360.00
7-10 Mbps	540.00
11-20 Mbps	1,470.00
21-50 Mbps	2,400.00
51-100 Mbps	3,600.00
101-200 Mbps	4,800.00
201-500 Mbps	7,200.00
501 Mbps - 1 Gbps	9,600.00

2. Ethernet Basic Ports

(a) Per Ethernet Basic Port	
Capacity	<u>1 yr monthly rate</u>
1-3 Mbps	\$242.00
4-6 Mbps	307.00
7-10 Mbps	372.00
11-20 Mbps	437.00
21-50 Mbps	500.00
51-100 Mbps	750.00
101-200 Mbps	1,000.00
201-500 Mbps	1,500.00
501 Mbps - 1 Gbps	2,000.00

(N)

Advice No. 08-05 Supplement A

Issued February 27, 2008

Effective March 23, 2008

Issued By CENTURYTEL OF WASHINGTON, INC. d/b/a CenturyTel
P.O. Box 9901, Vancouver, WA

By Chantel Mosby Title Manager, Tariffs and Compliance

WN U-4

CENTURYTEL OF WASHINGTON, INC.

ACCESS SERVICE

17. Rates and Charges (Cont'd)

17.5 Other Services (Cont'd)

17.5.8 Ethernet Service Rates

(N)

B. Recurring Charges (Cont'd)

3. Ethernet Interoffice Transport

(a) Ethernet Interoffice Transport per mile

Capacity	<u>1 yr monthly rate</u>
1-3 Mbps	\$24.00
4-6 Mbps	48.00
7-10 Mbps	72.00
11-20 Mbps	149.00
21-50 Mbps	225.00
51-100 Mbps	338.00
101-200 Mbps	450.00
201-500 Mbps	675.00
501 Mbps - 1 Gbps	900.00

4. Additional Customer Interface Ports

(b) Customer Interface Ports (per port)	<u>1 yr monthly rate</u> \$65.00
---	-------------------------------------

C. Term Discounts

The following discounts off the 1 year rates apply to 3 and 5 year contract terms:

3 yr	10%
5 yr	20%

(N)

Advice No. 08-05 Supplement A

Issued February 27, 2008

Effective March 23, 2008

Issued By CENTURYTEL OF WASHINGTON, INC. d/b/a CenturyTel
P.O. Box 9901, Vancouver, WA

By Chantel Mosby Title Manager, Tariffs and Compliance

ACCESS SERVICE

18. Rates and Charges

Rates and charges in this section apply to the following CenturyTel of Washington, Inc. exchanges:

Almira	Lake Quinault	Ritzville
Ashford	Lind	Royal City
Cathlamet	Nesplem	South Bend
Coulee City	Ocosta	Sprague
Curtis	Odessa	Starbuck
Edwall-Tyler	Pacific Beach	Vader
Eureka	Pe Ell	Wilbur
Harrington	Raymond	Wilson Creek
Humtulpis		Yacolt

Advice No. 03-28

Issued July 23, 2003

Effective August 23, 2003

Issued By CENTURYTEL OF WASHINGTON, INC. d/b/a CenturyTel
P.O. Box 9901, Vancouver, WA

(C)

By Pamela Donovan Title Supervisor, Tariffs

ACCESS SERVICE

18.1 Carrier Common Line Access Service⁽¹⁾ (C)
 Regulations, Rates and Charges for Carrier Common Line Access Service are the same as those set forth in WASHINGTON EXCHANGE CARRIER ASSOCIATION Tariff No. WNU-1.

18.2 Access Ordering
 Regulations concerning Access Ordering are set forth in Section 5. preceding.

	<u>USOC</u> <u>Reference</u>	<u>Charge</u>	Tariff
(A) <u>Access Order Charge</u> Per order		N/A	
(B) <u>Service Date Change Charge</u> Per order, per occurrence	5.2.2(A)	\$25.00 (M1)	
(C) <u>Partial Cancellation Charge</u> Per order, per occurrence	See Section 5.2.2(B), preceding		
(D) <u>Design Change Charge</u> Per order, per occurrence		\$25.00	5.2.2(C)
(E) <u>Expedited Order Charge</u> Per order, per occurrence	See Section 5.2.2(D) preceding		
(F) <u>Cancellation of Access Order Charge</u> Per order, per occurrence	See Section 5.2.3 preceding		

(1) See Sheet 426 for applicable exchanges (C)

Advice No. 05-05

Issued June 7, 2005	Effective July 7, 2005
Issued By	CENTURYTEL OF WASHINGTON, INC. d/b/a CenturyTel
	P.O. Box 9901, Vancouver, WA
By	Pamela Donovan Title Supervisor, Tariffs

ACCESS SERVICE

18. Rates and Charges (Cont'd)⁽¹⁾

(C)

18.3 Switched Access Service

Regulations concerning Switched Access are set forth in Section 6 preceding.

18.3.1 Nonrecurring Charges

	<u>USOC</u>	<u>Nonrecurring Charge</u>	<u>Tariff Reference</u>
(A) <u>Local Transport Installation</u> Per Entrance Facility			6.4.1(B)(1)
Voice Grade Four-Wire	NEFT4	\$56.00	
High Capacity DS1	NEFD1	\$400.00	
High Capacity DS3	NEFD3	\$ 750.00	
(B) <u>Trunk Activation</u> Per 24 Trunks Activated or Fraction thereof on a Per Order basis	NDTTA	\$418.00	6.4.1(B)(1)
(C) <u>FGC and FGD Trunk Conversion</u> Multifrequency Address Signaling to SS7 Signaling or SS7 Signaling to Multifrequency Address Signaling Per 24 Trunks Converted or Fraction thereof on a Per Order Basis	SS7TC	\$210.00	6.4.1(B)(3)
(D) <u>Common Channel Signaling</u> <u>Network Connection</u> Per Signaling Entrance Facility			
DS0	NCSEF	\$56.00	
DS1	NC1EF	\$400.00	

(1) See Sheet 426 for applicable exchanges

(C)

Advice No. 05-05

Issued June 7, 2005

Effective July 7, 2005

Issued By CENTURYTEL OF WASHINGTON, INC. d/b/a CenturyTel

P.O. Box 9901, Vancouver, WA

By Pamela Donovan

Title Supervisor, Tariffs

ACCESS SERVICE

18. Rates and Charges (Cont'd) ⁽¹⁾ (C)

18.3 Switched Access Service (Cont'd)

18.3.2 Local Transport

(A) <u>Premium Access</u>	<u>USOC</u>	<u>Monthly Rate</u>	<u>Tariff Reference</u>
(1) <u>Entrance Facility</u> Per Termination			6.1.3(A)(1)
Voice Grade Two-Wire	EFT2	\$65.00	
Voice Grade Four-Wire	EFT4	\$85.00	
High Capacity DS1	EFDS1	\$150.00	
High Capacity DS3	EFDS3	\$2,400.00	
Per Mile, Over 3 Miles			
High Capacity DS1	HCCTPM	N/A	
High Capacity DS3	H3CTPM	N/A	
(2) <u>Direct Trunked Transport</u>			6.1.3(A)(2)
<u>Direct Trunked Facility</u> Per Mile			
Voice Grade	DVCMF	\$1.35	
High Capacity DS1	D1CMF	\$10.66	
High Capacity DS3	D3CMF	\$225.00	
<u>Direct Trunked Termination</u> Per Termination			
Voice Grade	DVCMT	\$40.00	
High Capacity DS1	D1CMT	\$150.00	
High Capacity DS3	D3CMT	\$500.00	

(1) See Sheet 426 for applicable exchanges (C)

Advice No. 05-05

Issued June 7, 2005

Effective July 7, 2005

Issued By CENTURYTEL OF WASHINGTON, INC. d/b/a CenturyTel
 P.O. Box 9901, Vancouver, WA

By Pamela Donovan Title Supervisor, Tariffs

ACCESS SERVICE

18. Rates and Charges (Cont'd)⁽¹⁾ (C)

18.3 Switched Access Service Cont'd)

18.3.2 Local Transport (Cont'd)

(A) <u>Premium Access</u> (Cont'd)	<u>USOC</u>	<u>Monthly Rate</u>	<u>Tariff Reference</u>
(3) <u>Tandem Switched Transport</u>			6.1.3(A)(3)
<u>Tandem Switched Facility</u> Per Access Minute Per Mile	LTF	\$0.000120	
<u>Tandem Switched Termination</u> Per Access Minute Per Termination	LTT	\$0.001690	
<u>Tandem Switching</u> Per Access Minute Per Tandem	LTTAN	\$0.004579	
(B) <u>Non-Premium Access</u>			
<u>Tandem Switched Facility</u> Per Access Minute Per Mile	LTF	\$0.000100	
<u>Tandem Switched Termination</u> Per Access Minute Per Termination	LTT	\$0.001405	
<u>Tandem Switching</u> Per Access Minute Per Tandem	LTTAN	\$0.004579	
(C) <u>Multiplexing</u>			6.1.3(A)(5)
Per Arrangement DS3 to DS1	MUX31	\$385.00	
DS1 to Voice	MUX10	\$300.00	
DS1 to DS0	MUX10	\$300.00	

(1) See Sheet 426 for applicable exchanges (C)

Advice No. 05-05

Issued June 7, 2005

Effective July 7, 2005

Issued By CENTURYTEL OF WASHINGTON, INC. d/b/a CenturyTel
 P.O. Box 9901, Vancouver, WA

By Pamela Donovan Title Supervisor, Tariffs

ACCESS SERVICE

18. Rates and Charges (Cont'd)⁽¹⁾ (C)

18.3 Switched Access Service Cont'd)

18.3.2 Local Transport (Cont'd)

	<u>USOC</u>	<u>Monthly Rate</u>	<u>Tariff Reference</u>
(D) <u>Common Channel Signaling Network Connection</u>			
(1) <u>Signaling Network Access Link</u>			6.10.3
<u>Signaling Mileage Facility</u>			
Per Mile			
DS0	CCCMF	\$1.35	
DS1	C1CMF	\$10.66	
<u>Signaling Mileage Termination</u>			
Per Termination			
DS0	CCCMT	\$40.00	
DS1	C1CMT	\$150.00	
<u>Signaling Entrance Facility</u>			
Per Facility			
DS0	CCSEF	\$85.00	
DS1	C1SEF	\$150.00	
Per Mile, Over 3 Miles			
DS1	CSEFPM	\$65.00	
(2) <u>STP Port</u>			
Per Port	STPPT	\$900.00	

(1) See Sheet 426 for applicable exchanges (C)

Advice No. 05-05

Issued June 7, 2005

Effective July 7, 2005

Issued By CENTURYTEL OF WASHINGTON, INC. d/b/a CenturyTel
 P.O. Box 9901, Vancouver, WA

By Pamela Donovan Title Supervisor, Tariffs

ACCESS SERVICE

18. Rates and Charges (Cont'd) ⁽¹⁾ (C)

18.3 Switched Access Service (Cont'd)

18.3.2 Local Transport (Cont'd)

	<u>USOC</u>	<u>Monthly Rate</u>	<u>Tariff Reference</u>
(E) <u>Network Blocking</u> (Applies to FGD only) Per Blocked Call	NBCPC	\$0.0076	6.7.9
(F) <u>800 Data Base Access Service Queries</u> Per Query			6.10.3
Basic	800B	\$0.011770	
Vertical Feature	800V	\$0.011770	

(1) See Sheet 426 for applicable exchanges (C)

Advice No. 05-05

Issued June 7, 2005	Effective July 7, 2005
Issued By	CENTURYTEL OF WASHINGTON, INC. d/b/a CenturyTel
	P.O. Box 9901, Vancouver, WA
By	Pamela Donovan Title Supervisor, Tariffs

ACCESS SERVICE

18. Rates and Charges (Cont'd) ⁽¹⁾

18.3 Switched Access Service (Cont'd)

18.3.3 End Office

(A) <u>Local Switching</u>	<u>Monthly Rate</u>	<u>Tariff Reference</u>
(1) <u>Premium</u>		
Local Switching 1 – Originating Per Access Minute	\$0.041239	
Local Switching 2 – Terminating Per Access Minute	\$0.007148	
(2) <u>Non-Premium</u>		
Originating Per Access Minute	\$0.041239	
Terminating Per Access Minute	\$0.007148	
(B) <u>Line Terminations</u>		
(1) <u>Access Line Termination</u>		
Premium	N/A	
Transitional	N/A	
(C) <u>Intercept Intercept Charge</u>		
Premium	N/A	
Transitional	N/A	
(D) <u>Interim USF Additive</u>		
Per Terminating Access Minute	\$0.016851	
(E) <u>Reserved For Future Use</u>		(C) (D) (D)
(F) <u>Reserved For Future Use</u>		(C) (D) (D)

⁽¹⁾ See Sheet 426 for applicable exchanges

ACCESS SERVICE

18. Rates and Charges (Cont'd)⁽¹⁾

(C)

18.4 Special Access Service

Regulations concerning Special Access Service are set forth in Section 7 preceding.

18.4.1 Nonrecurring Charges

(A) Special Access Line

(1) <u>Installation</u>	<u>USOC</u>	Nonrecurring <u>Charge</u>	<u>Tariff Reference</u>
2 Wire		\$56.00	
4 Wire		\$56.00	
ISDN Repeater		N/A	
(2) <u>Multiplexing</u>			
Voice to Narrowband Per Arrangement	NMQX	\$ 72.00	
DS1 to Voice Per Arrangement	NMXDS	\$203.00	
(3) <u>Optional Facility Interface Combinations</u>			
<u>Narrowband</u>			
DB-43 TT (for use with NB4)	N9E2	\$ 38.00	
DB-10 IA (for use with NB5)	N9F1	\$ 38.00	
DB-43 IA (for use with NB5)	N9F2	\$ 38.00	

(1) See Sheet 426 for applicable exchanges

(C)

Advice No. 05-05

Issued June 7, 2005

Effective July 7, 2005

Issued By CENTURYTEL OF WASHINGTON, INC. d/b/a CenturyTel
 P.O. Box 9901, Vancouver, WA

By Pamela Donovan Title Supervisor, Tariffs

ACCESS SERVICE

18. Rates and Charges (Cont'd)⁽¹⁾

(C)

18.4 Special Access Service

Regulations concerning Special Access Service are set forth in Section 7 preceding.

18.4.1 Nonrecurring Charges(A) Special Access Line(3) Optional Facility Interface Combinations (Cont'd)

<u>Voice Grade</u>	<u>USOC</u>	<u>Nonrecurring Charge</u>	<u>Tariff Reference</u>
DB DA (for use with VG)	N9XQ	\$ 38.00	
DS AC (for use with VG)	N9KV	\$ 50.00	
DS DA (for use with VG)	N9KT	\$ 38.00	
DS EA (for use with VG)	N9K8	\$ 38.00	
DS LS (for use with VG)	N9KX	\$ 38.00	
DS NO (for use with VG)	N9KU	\$ 38.00	
LS SF (for use with VG)	N9YG	\$ 44.00	
NO DA (for use with VG)	N9X2	\$ 38.00	
NO NO (for use with VG)	N9GE	\$ 38.00	
SF LS (for use with VG)	N9MD	\$ 50.00	
SF EA (for use with VG)	N9PO	\$ 50.00	
SF AC (for use with VG)	N9L5	\$ 50.00	
SF GS (for use with VG)	N9PN	\$ 50.00	

(1) See Sheet 426 for applicable exchanges

(C)

Advice No. 05-05

Issued June 7, 2005

Effective July 7, 2005

Issued By CENTURYTEL OF WASHINGTON, INC. d/b/a CenturyTel
 P.O. Box 9901, Vancouver, WA

By Pamela Donovan Title Supervisor, Tariffs

ACCESS SERVICE

18. Rates and Charges (Cont'd)⁽¹⁾

(C)

18.4 Special Access Service (Cont'd)18.4.1 Nonrecurring Charges(Cont'd)(A) Special Access Line

	<u>USOC</u>	<u>Nonrecurring Charge</u>	<u>Tariff Reference</u>
(4) <u>Bridging</u>			
(a) Narrowband Bridges			
Telegraph Bridging (available with NB4 & NB5)			
2 Wire	BCNT2	\$ 12.00	
4 Wire	BCNT4	\$ 18.00	
(b) Voice Grade Bridges			
Voice Bridging (available with VG)			
2 Wire	BCNV2	\$ 12.00	
4 Wire	BCNV4	\$ 18.00	
Data Bridging (available with VG)			
2 Wire	BCND2	\$ 12.00	
4 Wire	BCND4	\$ 18.00	
(5) <u>Conditioning</u>			
C-Type	NX1C	\$184.00	
DA Type	NXDC	\$184.00	
(6) <u>Improved Return Loss</u>			
2 Wire	NRL2W	\$ 37.00	
4 Wire	NRL4W	\$ 74.00	

(1) See Sheet 426 for applicable exchanges

(C)

Advice No. 05-05

Issued June 7, 2005

Effective July 7, 2005

Issued By CENTURYTEL OF WASHINGTON, INC. d/b/a CenturyTel
 P.O. Box 9901, Vancouver, WA

By Pamela Donovan Title Supervisor, Tariffs

ACCESS SERVICE

18. Rates and Charges (Cont'd) ⁽¹⁾ (C)

18.4 Special Access Service (Cont'd)

18.4.1 Nonrecurring Charges (Cont'd)

(B) High Capacity Access Service

	<u>USOC</u>	<u>Rate</u>	<u>Tariff Reference</u>
(1) <u>Installation</u>			
(a) High Capacity Access Line	NCEUC	\$ 94.00	
(b) High Capacity Transport	NCSTB	\$418.00	

18.4.2 Surcharge for Special Access Service

	<u>USOC</u>	<u>Monthly Rate</u>	<u>Tariff Reference</u>
<u>Special Access Surcharge</u> Per Voice Grade Equivalent		\$0.00	7.4.2

(1) See Sheet 426 for applicable exchanges (C)

Advice No. 05-05

Issued June 7, 2005	Effective July 7, 2005
Issued By	CENTURYTEL OF WASHINGTON, INC. d/b/a CenturyTel
	P.O. Box 9901, Vancouver, WA
By	Pamela Donovan
	Title Supervisor, Tariffs

ACCESS SERVICE

18. Rates and Charges (Cont'd) ⁽¹⁾

(C)

18.4 Special Access Service (Cont'd)

18.4.3 Special Access Lines

	<u>USOC</u>	<u>Monthly Rate</u>	
(A) Access Line			
Each:			
2-Wire Voice	VGCT2		\$ 25.00
2-Wire INWATS	VG2WI		\$ 25.00
2-Wire OUTWATS	VG2WO		\$ 25.00
4-Wire Voice	VGCT4		\$ 35.00
4-Wire INWATS	VG4WI		\$ 35.00
4-Wire OUTWATS	VG4WO		\$ 35.00
ISDN Repeater	ISDNR		N/A
	<u>USOC</u>	Monthly Rates	
		<u>Fixed</u>	<u>Per Mile</u>
(B) <u>Special Transport</u>			
Per Special Access Service			
Per Month	VGCMT	\$ 4.85	
Per Mile	VGCMF		\$1.35
(C) <u>ISDN Transport</u>			
Per Month	ISCMT	N/A	
Per Mile	ISCMF		N/A

(1) See Sheet 426 for applicable exchanges

(C)

Advice No. 05-05

Issued June 7, 2005

Effective July 7, 2005

Issued By CENTURYTEL OF WASHINGTON, INC. d/b/a CenturyTel
 P.O. Box 9901, Vancouver, WA

By Pamela Donovan Title Supervisor, Tariffs

ACCESS SERVICE

18. Rates and Charges (Cont'd) ⁽¹⁾

(C)

18.4 Special Access Service (Cont'd)

18.4.3 Special Access Lines (Cont'd)

(D) <u>Bridging</u>	<u>USOC</u>	<u>Monthly Rate</u>
<u>Narrow Band</u>		
2 Wire	BCNT2	\$ 5.35
4 Wire	BCNT4	\$11.65
<u>Voice Grade</u>		
2 Wire	BCNV2	\$ 6.00
4 Wire	BCNV4	\$14.00
<u>Data</u>		
2 Wire	BCND2	\$ 13.50
4 Wire	BCND4	\$ 13.50
<u>Data Capability</u>		\$4.95
<u>(E) Conditioning</u>		
C1-Type	X1C	\$1.15
DA-Type	XDC	\$24.85
<u>(F) Improved Return Loss</u>		
2 Wire	1RL2W	\$ 3.60
4 Wire	1RL4W	\$5.00
<u>(G) Signaling Capability</u>		\$12.95
<u>(H) Digital Data Service - Channel Termination</u>		
2.4		\$40.00
4.8		\$45.00
9.6		\$50.00
19.2		\$75.00
56K		\$90.00
64K		\$99.00
<u>Special Transport</u>		
Per Special Access Service		
Per Month		\$ 10.00
Per Mile		\$1.35
Bridging		\$7.85

(1) See Sheet 426 for applicable exchanges

(C)

Advice No. 05-05

Issued June 7, 2005

Effective July 7, 2005

Issued By CENTURYTEL OF WASHINGTON, INC. d/b/a CenturyTel

P.O. Box 9901, Vancouver, WA

By Pamela Donovan

Title Supervisor, Tariffs

ACCESS SERVICE

18. Rates and Charges (Cont'd)⁽¹⁾

(C)

18.4 Special Access Service (Cont'd)18.4.3 Special Access Lines (Cont'd)(G) Optional Facility Interface Combinations

	<u>USOC</u>	<u>Monthly Rate</u>
<u>Narrowband</u>		
DB-43 TT (for use with NB4)	9E2	N/A
DB-10 IA (for use with NB5)	9F1	N/A
DB-43 IA (for use with NB5)	9F2	N/A
<u>Voice Grade</u>		
DB DA (for use with VG)	9XQ	N/A
DS AC (for use with VG)	9KV	N/A
DS DA (for use with VG)	9KT	N/A
DS EA (for use with VG)	9K8	N/A
DS LS (for use with VG)	9KX	N/A
DS NO (for use with VG)	9KU	N/A
LS SF (for use with VG)	9YG	N/A
NO DA (for use with VG)	9X2	N/A
NO NO (for use with VG)	9GE	N/A
SF LS (for use with VG)	9MD	N/A
SF EA (for use with VG)	9PO	N/A
SF AC (for use with VG)	9L5	N/A
SF GS (for use with VG)	9PN	N/A

(1) See Sheet 426 for applicable exchanges

(C)

Advice No. 05-05

Issued June 7, 2005

Effective July 7, 2005

Issued By CENTURYTEL OF WASHINGTON, INC. d/b/a CenturyTel
 P.O. Box 9901, Vancouver, WA

By Pamela Donovan Title Supervisor, Tariffs

ACCESS SERVICE

18. Rates and Charges (Cont'd) ⁽¹⁾

(C)

18.4 Special Access Service (Cont'd)

18.4.4 High Capacity Service

Regulations concerning High Capacity Service are set forth in 7.10 preceding.

	<u>USOC</u>	<u>Fixed</u>	<u>Monthly Rates Per Mile</u>
(A) <u>High Capacity Access Line</u>			
DS1 Per High Capacity Access Line Per Month	HCEUC	\$ 150.00	
Per Mile	HCEUF		N/A
 DS3 Per High Capacity Access Line Per Month	HCEUC	 \$ 2,400.00	
Per Mile	HCEUF		N/A
 (B) <u>High Capacity Transport</u>			
DS1 Per High Capacity Service Per Month	VGCMT	\$80.00	
Per Mile	VGCMF		\$14.00
 DS3 Per High Capacity Service Per Month	VGCMT	 \$500.00	
Per Mile	VGCMF		\$225.00

(1) See Sheet 426 for applicable exchanges

(C)

Advice No. 05-05

Issued June 7, 2005

Effective July 7, 2005

Issued By CENTURYTEL OF WASHINGTON, INC. d/b/a CenturyTel
 P.O. Box 9901, Vancouver, WA

By Pamela Donovan Title Supervisor, Tariffs

ACCESS SERVICE

18. Rates and Charges (Cont'd)⁽¹⁾ (C)

18.4 Special Access Service (Cont'd)

18.4.4 High Capacity Service (Cont'd)

(C) Optional Features and Functions

	<u>USOC</u>	<u>Monthly Rate</u>
(1) <u>Multiplexing</u> Per Arrangement		
DS3 to DS1	HCMP3	\$385.00
DS1 to Voice	HCM1V	\$300.00
DS1 to DS0	HCM10	\$300.00

(1) See Sheet 426 for applicable exchanges (C)

Advice No. 05-05

Issued June 7, 2005 Effective July 7, 2005
 Issued By CENTURYTEL OF WASHINGTON, INC. d/b/a CenturyTel
 P.O. Box 9901, Vancouver, WA
 By Pamela Donovan Title Supervisor, Tariffs

ACCESS SERVICE

18. Rates and Charges (Cont'd) ⁽¹⁾

(C)

18.4 Special Access Service (Cont'd)

18.4.4 High Capacity Service (Cont'd)

(C) Optional Features and Functions (Cont'd)

	<u>USOC</u>	<u>Monthly Rate</u>
(2) <u>Automatic Loop Transfer</u> Per arrangement*	HCALT	N/A
(3) <u>Transfer Arrangement</u> (key activated **or Dial-Up ***) Per four port arrangement including control channel termination ****	HCTA	N/A
(D) <u>Clear Channel Capability</u> Per 1.544 Mbps transmission path	CCCC	N/A

* An additional Channel Termination charge will apply whenever the spare line is provided as a leg to the customer designated premises.

** The key activated control channel is rated as a Metallic Channel Termination and Channel Mileage, if applicable.

*** The Dial-Up option requires the customer to purchase the Controller Arrangement from 13.3.4 preceding.

**** An additional Channel Termination charge will apply whenever a spare channel is configured as a leg to the customer designated premises. Additional channel mileage charges will also apply when the transfer arrangement is not located in the customer designated premises serving wire center.

(1) See Sheet 426 for applicable exchanges

(C)

Advice No. 05-05

Issued June 7, 2005

Effective July 7, 2005

Issued By CENTURYTEL OF WASHINGTON, INC. d/b/a CenturyTel
 P.O. Box 9901, Vancouver, WA

By Pamela Donovan Title Supervisor, Tariffs

ACCESS SERVICE

18. Rates and Charges (Cont'd) ⁽¹⁾

(C)

18.5 Other Services

18.5.1 Additional Engineering

Regulations concerning Additional Engineering are set forth in Section 13.1 preceding.

<u>Additional Engineering Periods</u>	<u>USOC</u>	<u>Each Half Hour or Fraction Thereof</u>	<u>Tariff Reference</u>
(A) <u>Basic Time</u> Regularly scheduled working hours, Per Engineer	AEHBD	\$37.87	13.1
(B) <u>Overtime</u> Outside of regularly scheduled working hours on a scheduled work day, Per Engineer	AEHOD	\$56.81	13.1
(C) <u>Premium Time</u> Outside of scheduled work day, Per Engineer	AEHPD	\$75.74	13.1

(1) See Sheet 426 for applicable exchanges

(C)

Advice No. 05-05

Issued June 7, 2005

Effective July 7, 2005

Issued By CENTURYTEL OF WASHINGTON, INC. d/b/a CenturyTel
 P.O. Box 9901, Vancouver, WA

By Pamela Donovan Title Supervisor, Tariffs

ACCESS SERVICE

18. Rates and Charges (Cont'd) ⁽¹⁾

(C)

18.5 Other Services (Cont'd)

18.5.2 Additional Labor

Regulations concerning Additional Labor are set forth in Section 13.2 preceding.

<u>Additional Labor Periods</u>	<u>USOC</u>	<u>Each Half Hour or Fraction Thereof</u>	<u>Tariff Reference</u>
(A) <u>Installation or Repair</u>			
<u>Overtime</u>			
Outside of regularly scheduled working hours on a scheduled work day, Per Technician			
	ALHOD	\$41.59	13.2
<u>Premium Time</u>			
Outside of scheduled work day, Per Technician			
	ALHPD	\$55.45	13.2
(B) <u>Standby</u>			
<u>Basic Time</u>			
Regularly scheduled working hours, Per Technician			
	ALTBT	\$27.73	13.2
<u>Overtime</u>			
Outside of regularly scheduled working hours on a scheduled work day, Per Technician			
	ALTOT	\$41.59	13.2
<u>Premium Time</u>			
Outside of scheduled work day, Per Technician			
	ALTPT	\$55.45	13.2

(1) See Sheet 426 for applicable exchanges

(C)

Advice No. 05-05

Issued June 7, 2005

Effective July 7, 2005

Issued By CENTURYTEL OF WASHINGTON, INC. d/b/a CenturyTel
 P.O. Box 9901, Vancouver, WA

By Pamela Donovan Title Supervisor, Tariffs

ACCESS SERVICE

18. Rates and Charges (Cont'd) ⁽¹⁾

(C)

18.5 Other Services (Cont'd)

18.5.2 Additional Labor (Cont'd)

(C) Testing and Maintenance with other Telephone Companies, or Other Labor or NonScheduled Testing

	<u>USOC</u>	<u>Each Half Hour or Fraction Thereof</u>	<u>Tariff Reference</u>
<u>Basic Time</u> Regularly scheduled working hours, Per Technician	ALKBT	\$27.73	13.2
<u>Overtime</u> Outside of regularly scheduled working hours on a scheduled work day, Per Technician	ALKOT	\$41.59	13.2
<u>Premium Time</u> Outside of scheduled work day, Per Technician	ALKPT	\$55.45	13.2

(D) Maintenance of Service

<u>Basic Time</u> Regularly scheduled working hours, per technician	MVBBD	\$27.73	
<u>Overtime</u> Outside of regularly scheduled working hours on a scheduled work day, -per technician	MVVOD	\$41.59*	
<u>Premium Time</u> Outside of scheduled working day, per technician	MVPDP	\$55.45*	

* A call out of a Telephone Company employee at a time not consecutive with the employee's scheduled work period is subject to a minimum charge of four hours.

(1) See Sheet 426 for applicable exchanges

(C)

Advice No. 05-05

Issued June 7, 2005	Effective July 7, 2005
Issued By	CENTURYTEL OF WASHINGTON, INC. d/b/a CenturyTel
	P.O. Box 9901, Vancouver, WA
By	Pamela Donovan
	Title Supervisor, Tariffs

ACCESS SERVICE

18. Rates and Charges (Cont'd) ⁽¹⁾

(C)

18.5 Other Services (Cont'd)

18.5.3 Miscellaneous Services

Regulations concerning Miscellaneous Services are set forth in Section 13.3 preceding.

(A)	<u>Restoration Priority Charge</u>	<u>USOC</u>	<u>Nonrecurring</u>
	Per service arranged	RSTPR	\$180.00
(B)	<u>IntraLATA Toll Presubscription Charge</u>		Nonrecurring
	(1) IntraLATA Toll Presubscription Change Charge Per Telephone Exchange line or trunk		\$ 5.00#
	(2) Unauthorized IPIC Change Charge		\$25.00
			<u>Rate</u>
	(b) <u>IntraLATA Dialing Parity Rate</u> Originating Intrastate IntraLATA Access Minutes, Per Minute		\$0.000979*
(C)	<u>Provision of Standard Billing Detail USOC Rates and/or Information in magnetic tape format:</u>		
	per record processed	ASBIR	\$.01
	per tape or data file	ASBIF	\$40.00

When a customer simultaneously requests a change to their interLATA carrier and their intraLATA carrier, only the InterLATA change charge as specified in the interstate tariff applies. See Telephone Utilities Exchange Carrier Association ("TUECA") Tariff FCC No. 2.

* A call-out of a Telephone Company employee at a time not consecutive with the employee's scheduled work period is subject to a minimum charge of four hours.

(1) See Sheet 426 for applicable exchanges

(C)

Advice No. 05-05

Issued June 7, 2005

Effective July 7, 2005

Issued By CENTURYTEL OF WASHINGTON, INC. d/b/a CenturyTel
 P.O. Box 9901, Vancouver, WA

By Pamela Donovan

Title Supervisor, Tariffs

ACCESS SERVICE

18. Rates and Charges (Cont'd) ⁽¹⁾

(C)

18.5 Other Services (Cont'd)

18.5.4 Special Federal Government Access Services

Regulations concerning Special Federal Government Access Services are as set forth in Section 10, preceding.

(A) <u>Voice Grade Secure Communications</u>	<u>Monthly Rates</u>	<u>Nonrecurring Charges</u>	<u>Termination Charges</u>
Type I, each T-3 Conditioning,	ICB rates and charges apply		
Additional Conditioning, per service termination	ICB rates and charges apply		
Type II, each G-1 Conditioning,	ICB rates and charges apply		
Type III, each G-2 Conditioning,	ICB rates and charges apply		
Additional Conditioning, per service termination	ICB rates and charges apply		
Type IV, each G-3 Conditioning,	ICB rates and charges apply		
Additional Conditioning, per service termination	ICB rates and charges apply		

(B) Wideband Digital Special Access Service

<u>Wideband Secure Communications</u>	<u>Monthly Rates</u>	<u>Nonrecurring Charges</u>	<u>Termination Charges</u>
Type I, each	ICB rates and charges apply		
Type II, each	ICB rates and charges apply		
Type III, each	ICB rates and charges apply		

(1) See Sheet 426 for applicable exchanges

(C)

Advice No. 05-05

Issued June 7, 2005	Effective July 7, 2005
Issued By	CENTURYTEL OF WASHINGTON, INC. d/b/a CenturyTel
	P.O. Box 9901, Vancouver, WA
By	Pamela Donovan Title Supervisor, Tariffs

ACCESS SERVICE

18. Rates and Charges (Cont'd)⁽¹⁾

(C)

18.5 Other Services (Cont'd)

18.5.5 Special Facilities Routing of Access Services

Regulations concerning Special Facilities Routing of Access Services are as set forth in Section 11, preceding.

(A) Diversity

For each service provided in accordance with 11.1.1 preceding, the rates and charges will be developed on an individual case basis.

(B) Avoidance

For each service provided in accordance with 11.1.2 preceding, the rates and charges will be developed on an individual case basis.

(C) Diversity and Avoidance Combined

For each service provided in accordance with 11.1.1 and 11.1.2 preceding, combined, the rates and charges will be developed on an individual case basis.

(D) Cable-Only Facilities

For each service provided in accordance with 11.1.4 preceding, the rates and charges will be developed on an individual case basis.

(1) See Sheet 426 for applicable exchanges

(C)

Advice No. 05-05

Issued June 7, 2005

Effective July 7, 2005

Issued By CENTURYTEL OF WASHINGTON, INC. d/b/a CenturyTel
P.O. Box 9901, Vancouver, WA

By Pamela Donovan

Title Supervisor, Tariffs

ACCESS SERVICE

18. Rates and Charges (Cont'd) ⁽¹⁾

(C)

18.5 Other Services (Cont'd)

18.5.7 Billing and Collection

Regulations concerning Billing and Collection are as set forth in Section 8, preceding.

(A) <u>Recording Service</u>	<u>USOC</u>	<u>Rate</u>
(1) <u>Recording</u>		
Per Customer Message	BARRM	\$0.00
Per Special Order	BARRO	\$0.00
(2) <u>Assembling and Editing</u>		
Per Customer Message *, **	BARAM	\$0.00
(3) <u>Provision of Message Detail</u>		
Per Record Processed**	BARAR	\$0.00
Per Tape or Data File**	BARAF	\$0.00
 (B) <u>Message Billing Service</u>		
	<u>USOC</u>	<u>Rate</u>
(1) <u>Large Volume Customers</u>		
(over 1.5 million messages annually)		
Message Processing Service		
Per Message	BABTU	\$.08825
 (C) <u>Billing Analysis Service</u>		

The rates and charge for Billing Analysis Service are on an Individual Case Basis (ICB).

* Not applicable when Message Processing Service, as set forth in 8.2.1 is provided to the customer except as set forth in 8.2.1(B)(1)(c) and 8.2.1(B)(2)(d).

** This rate is for customers with more than 1.5 million messages annually.

(1) See Sheet 426 for applicable exchanges

(C)

Advice No. 05-05

Issued June 7, 2005

Effective July 7, 2005

Issued By CENTURYTEL OF WASHINGTON, INC. d/b/a CenturyTel
 P.O. Box 9901, Vancouver, WA

By Pamela Donovan Title Supervisor, Tariffs

ACCESS SERVICE

18. Rates and Charges (Cont'd) ⁽¹⁾

(C)

18.5 Other Services (Cont'd)

18.5.7 Billing and Collection

(D) Billing Information Service

		Rates*			Service and Account	Detail
		<u>USOC</u>	<u>Message on Detail</u>	<u>Detail</u>	<u>Detail</u>	<u>Tape</u>
	Equipment					
	(A) <u>CRIS 10 Working Day Information Service,</u> Paper output, per study		ICB	ICB	ICB	
	Magnetic tape output, per study	2FSM	ICB	ICB	ICB	
	Magnetic tape output, per tape	2FSMT				
	ICB					
	Fiche output, per study		ICB	ICB	ICB	

* The Quick Turnaround per record charge and the per tape charge is three times the 10 working day per record charge and per tape charge.

	(B) <u>DBAS Information Service,</u>	<u>USOC</u> 1FS++		<u>Rate</u>
	Paper output, per record processed			#
	Magnetic tape, per record processed			#
	per tape or data file			#
	Fiche output, per record processed			#
	(C) <u>CRIS File or DBAS File Interrogation,</u>	2FQ++		
	Per request received			#

These offerings are only provided where facilities are available. When facilities can be made available with the agreement of the Telephone Company, ICB rates and charges apply.

(1) See Sheet 426 for applicable exchanges

(C)

Advice No. 05-05

Issued June 7, 2005	Effective July 7, 2005
Issued By	CENTURYTEL OF WASHINGTON, INC. d/b/a CenturyTel
	P.O. Box 9901, Vancouver, WA
By	Pamela Donovan
	Title Supervisor, Tariffs

ACCESS SERVICE

18. Rates and Charges (Cont'd)⁽¹⁾

(C)

18.5 Other Services (Cont'd)18.5.7 Billing and Collection(D) Billing Information Service

	<u>USOC</u>	<u>Rates</u>
(4) <u>Program Development charge</u> , (applicable to work performed outside the Telephone Company's normal work schedule and/or which requires additions to the work force) Per hour	BAPPD	ICB
(5) <u>Customer Name and Address Information Service</u> , Interrogation, Per request received	CNT++	*
Interrogation confirmation, Per request confirmed	CN6++	*
(6) <u>Marking of Message End User Accounts</u> , Marking, per end user account	BAM++	ICB
Maintenance of mark, Per end user account per month		ICB
(7) <u>Updating of customer data bases or files</u> , Per record transmitted	BAG++	ICB
(8) <u>Provision of Bill Information service</u> , Per Special Order	BAJ++	ICB

* These offerings are only provided where facilities are available. When facilities can be made available with the agreement of the Telephone Company, ICB rates and charges apply.

(1) See Sheet 426 for applicable exchanges

(C)

Advice No. 05-05

Issued June 7, 2005

Effective July 7, 2005

Issued By CENTURYTEL OF WASHINGTON, INC. d/b/a CenturyTel
 P.O. Box 9901, Vancouver, WA

By Pamela Donovan Title Supervisor, Tariffs

WN U-4

CENTURYTEL OF WASHINGTON, INC.

ACCESS SERVICE

18. Rates and Charges (Cont'd)

18.5 Other Services (Cont'd)

18.5.8 Ethernet Service Rates

(N)

A. Nonrecurring Charges

- | | | |
|----|--|---|
| 1. | Service Order | See Section 5 |
| 2. | Move Same Building | 50% Ethernet CT
No Service Order Charge |
| 3. | Move Same SWC | New CT NRCs Apply and
Service Order Charge |
| 4. | Move Different SWC | New CT NRCs Apply and
Service Order Charge |
| 5. | Ethernet Channel Terminations
Per Termination | \$760.00 |
| 6. | Ethernet Basic Ports
Per Port | \$190.00 |
| 7. | Interoffice Transport | \$0.00 |

(N)

Advice No. 08-05

Issued February 22, 2008

Effective March 23, 2008

Issued By CENTURYTEL OF WASHINGTON, INC. d/b/a CenturyTel

P.O. Box 9901, Vancouver, WA

By Chantel Mosby

Title Manager, Tariffs and Compliance

WN U-4

CENTURYTEL OF WASHINGTON, INC.

ACCESS SERVICE

18. Rates and Charges (Cont'd)18.5 Other Services (Cont'd)

18.5.8 Ethernet Service Rates

(N)

B. Recurring Charges

1. Ethernet Channel Terminations

(a) Per termination	
Capacity	<u>1 yr monthlyrate</u>
1-3 Mbps	\$180.00
4-6 Mbps	360.00
7-10 Mbps	540.00
11-20 Mbps	1,470.00
21-50 Mbps	2,400.00
51-100 Mbps	3,600.00
101-200 Mbps	4,800.00
201-500 Mbps	7,200.00
501 Mbps - 1 Gbps	9,600.00

2. Ethernet Basic Ports

(a) Per Ethernet Basic Port	
Capacity	<u>1 yr Monthly rate</u>
1-3 Mbps	\$242.00
4-6 Mbps	307.00
7-10 Mbps	372.00
11-20 Mbps	437.00
21-50 Mbps	500.00
51-100 Mbps	750.00
101-200 Mbps	1,000.00
201-500 Mbps	1,500.00
501 Mbps - 1 Gbps	2,000.00

(N)

Advice No. 08-05 Supplement A

Issued February 27, 2008

Effective March 23, 2008

Issued By CENTURYTEL OF WASHINGTON, INC. d/b/a CenturyTel
P.O. Box 9901, Vancouver, WA

By Chantel Mosby Title Manager, Tariffs and Compliance

WN U-4

CENTURYTEL OF WASHINGTON, INC.

ACCESS SERVICE

18. Rates and Charges (Cont'd)

18.5 Other Services (Cont'd)

18.5.8 Ethernet Service Rates

(N)

B. Recurring Charges (Cont'd)

3. Ethernet Interoffice Transport

(a) Ethernet Interoffice Transport per mile

Capacity	<u>1 yr monthly rate</u>
1-3 Mbps	\$24.00
4-6 Mbps	48.00
7-10 Mbps	72.00
11-20 Mbps	149.00
21-50 Mbps	225.00
51-100 Mbps	338.00
101-200 Mbps	450.00
201-500 Mbps	675.00
501 Mbps - 1 Gbps	900.00

4. Additional Customer Interface Ports

(c) Customer Interface Ports (per port)	<u>1 yr monthly rate</u>
	\$65.00

C. Term Discounts

The following discounts off the 1 year rates apply to 3 and 5 year contract terms:

3 yr	10%
5 yr	20%

(N)

Advice No. 08-05 Supplement A

Issued February 27, 2008

Effective March 23, 2008

Issued By CENTURYTEL OF WASHINGTON, INC. d/b/a CenturyTel
P.O. Box 9901, Vancouver, WA

By Chantel Mosby Title Manager, Tariffs and Compliance

BTOP Comprehensive Community Infrastructure Pro Forma Financial Projections

Please complete the Income Statement, Balance Sheet, Cash Flows, and NPV-IRR Table worksheets. Key assumptions used to formulate these financial projections should be listed in the Key Assumptions worksheet. Please note that these are **project-specific** projections, in contrast to the historical financial information which is provided at the organizational level.

Please refer to the Comprehensive Community Infrastructure Grant Guidance for detailed instructions on the completing this upload.

Applicants are required to provide this upload as an Excel file, and not to convert it to a PDF prior to upload. Applicants may make adjustments to the format of the templates as necessary to provide the most effective presentation of the data for their specific project, but should not remove major headings (*e.g.* Revenues and Expenses on the Income Statement) or provide less detailed information than would be required to complete the provided templates.

Income Statement

	Forecast Period							
	2010	2011	2012	2013	2014	2015	2016	2017
Revenues								
Broadband Offerings								
Wholesale Data	\$ 413,605	\$ 1,240,816	\$ 2,068,027	\$ 2,297,808	\$ 2,527,589	\$ 2,757,370	\$ 2,987,150	\$ 3,216,931
Retail Data	\$ -	\$ -	\$ -	\$ -	\$ -	\$ -	\$ -	\$ -
Dark Fiber	\$ -	\$ -	\$ -	\$ -	\$ -	\$ -	\$ -	\$ -
Collocation	\$ -	\$ -	\$ -	\$ -	\$ -	\$ -	\$ -	\$ -
Other (list specific services)	\$ -	\$ -	\$ -	\$ -	\$ -	\$ -	\$ -	\$ -
Other Network Driven Revenues								
Video Services	\$ -	\$ -	\$ -	\$ -	\$ -	\$ -	\$ -	\$ -
Voice Services (local/toll/long distance)	\$ -	\$ -	\$ -	\$ -	\$ -	\$ -	\$ -	\$ -
Other (list specific services)	\$ -	\$ -	\$ -	\$ -	\$ -	\$ -	\$ -	\$ -
Universal Service Fund	\$ -	\$ -	\$ -	\$ -	\$ -	\$ -	\$ -	\$ -
Installation Revenues	\$ -	\$ -	\$ -	\$ -	\$ -	\$ -	\$ -	\$ -
Other Revenues (grant proceeds)	\$ 27,640,399	\$ 27,640,399	\$ -	\$ -	\$ -	\$ -	\$ -	\$ -
Other Revenues (matching funds)	\$ 11,860,790	\$ 11,860,790	\$ -	\$ -	\$ -	\$ -	\$ -	\$ -
Total Revenues	\$ 39,914,794	\$ 40,742,005	\$ 2,068,027	\$ 2,297,808	\$ 2,527,589	\$ 2,757,370	\$ 2,987,150	\$ 3,216,931
Expenses								
Backhaul	\$ -	\$ -	\$ -	\$ -	\$ -	\$ -	\$ -	\$ -
Network Maintenance/Monitoring	\$ 251,265	\$ 753,796	\$ 1,256,327	\$ 1,395,918	\$ 1,535,510	\$ 1,675,102	\$ 1,814,694	\$ 1,954,286
Utilities	\$ -	\$ -	\$ -	\$ -	\$ -	\$ -	\$ -	\$ -
Leasing	\$ -	\$ -	\$ -	\$ -	\$ -	\$ -	\$ -	\$ -
Sales/Marketing	\$ -	\$ -	\$ -	\$ -	\$ -	\$ -	\$ -	\$ -
Customer Care	\$ -	\$ -	\$ -	\$ -	\$ -	\$ -	\$ -	\$ -
Billing	\$ -	\$ -	\$ -	\$ -	\$ -	\$ -	\$ -	\$ -
Corporate G&A	\$ 65,488	\$ 196,463	\$ 327,438	\$ 327,438	\$ 327,438	\$ 327,438	\$ 327,438	\$ 327,438
Other Operating Expense	\$ -	\$ -	\$ -	\$ -	\$ -	\$ -	\$ -	\$ -
Total	\$ 316,753	\$ 950,258	\$ 1,583,764	\$ 1,723,356	\$ 1,862,948	\$ 2,002,540	\$ 2,142,132	\$ 2,281,723
EBITDA	\$ 39,598,041	\$ 39,791,746	\$ 484,263	\$ 574,452	\$ 664,641	\$ 754,830	\$ 845,019	\$ 935,208
Depreciation	\$ 2,673,425	\$ 5,346,850	\$ 5,346,850	\$ 5,346,850	\$ 5,346,850	\$ 5,346,850	\$ 5,346,850	\$ 5,346,850
Amortization	\$ -	\$ -	\$ -	\$ -	\$ -	\$ -	\$ -	\$ -
Earnings Before Interest and Taxes	\$ 36,924,616	\$ 34,444,896	\$ (4,862,587)	\$ (4,772,398)	\$ (4,682,209)	\$ (4,592,020)	\$ (4,501,831)	\$ (4,411,642)
Interest Expense	\$ -	\$ -	\$ -	\$ -	\$ -	\$ -	\$ -	\$ -
Income Before Taxes	\$ 36,924,616	\$ 34,444,896	\$ (4,862,587)	\$ (4,772,398)	\$ (4,682,209)	\$ (4,592,020)	\$ (4,501,831)	\$ (4,411,642)
Property Tax (B&O tax)	\$ 420,810	\$ 433,218	\$ 31,020	\$ 34,467	\$ 37,914	\$ 41,361	\$ 44,807	\$ 48,254
Income Taxes	\$ -	\$ -	\$ -	\$ -	\$ -	\$ -	\$ -	\$ -
Net Income	\$ 36,503,806	\$ 34,011,678	\$ (4,893,608)	\$ (4,806,865)	\$ (4,720,123)	\$ (4,633,381)	\$ (4,546,639)	\$ (4,459,896)

Balance Sheet

	Forecast Period							
	2010	2011	2012	2013	2014	2015	2016	2017
Assets								
<i>Current Assets</i>								
Cash	\$ 89,648	\$ 360,592	\$ 813,835	\$ 1,353,820	\$ 1,980,547	\$ 2,694,016	\$ 3,494,228	\$ 4,381,182
Marketable Securities	\$ -	\$ -	\$ -	\$ -	\$ -	\$ -	\$ -	\$ -
Accounts Receivable	\$ -	\$ -	\$ -	\$ -	\$ -	\$ -	\$ -	\$ -
Notes Receivable	\$ -	\$ -	\$ -	\$ -	\$ -	\$ -	\$ -	\$ -
Inventory	\$ -	\$ -	\$ -	\$ -	\$ -	\$ -	\$ -	\$ -
Prepayments	\$ -	\$ -	\$ -	\$ -	\$ -	\$ -	\$ -	\$ -
Other Current Assets	\$ -	\$ -	\$ -	\$ -	\$ -	\$ -	\$ -	\$ -
Total Current Assets	\$ 89,648	\$ 360,592	\$ 813,835	\$ 1,353,820	\$ 1,980,547	\$ 2,694,016	\$ 3,494,228	\$ 4,381,182
<i>Non-Current Assets</i>								
Long-Term Investments	\$ -	\$ -	\$ -	\$ -	\$ -	\$ -	\$ -	\$ -
Amortizable Asset (Net of Amortization)	\$ -	\$ -	\$ -	\$ -	\$ -	\$ -	\$ -	\$ -
Plant in Service	\$ 39,087,584	\$ 78,175,167	\$ 78,175,167	\$ 78,175,167	\$ 78,175,167	\$ 78,175,167	\$ 78,175,167	\$ 78,175,167
Less: Accumulated Depreciation	\$ (2,673,425)	\$ (8,020,275)	\$ (13,367,126)	\$ (18,713,976)	\$ (24,060,826)	\$ (29,407,677)	\$ (34,754,527)	\$ (40,101,377)
Net Plant	\$ 36,414,158	\$ 70,154,892	\$ 64,808,041	\$ 59,461,191	\$ 54,114,341	\$ 48,767,490	\$ 43,420,640	\$ 38,073,790
Other	\$ -	\$ -	\$ -	\$ -	\$ -	\$ -	\$ -	\$ -
Total Non-Current Assets	\$ 36,414,158	\$ 70,154,892	\$ 64,808,041	\$ 59,461,191	\$ 54,114,341	\$ 48,767,490	\$ 43,420,640	\$ 38,073,790
Total Assets	\$ 36,503,806	\$ 70,515,484	\$ 65,621,876	\$ 60,815,011	\$ 56,094,887	\$ 51,461,507	\$ 46,914,868	\$ 42,454,971
Liabilities and Owners' Equity								
<i>Liabilities</i>								
<i>Current Liabilities</i>								
Accounts Payable	\$ -	\$ -	\$ -	\$ -	\$ -	\$ -	\$ -	\$ -
Notes Payable	\$ -	\$ -	\$ -	\$ -	\$ -	\$ -	\$ -	\$ -
Other Current Liabilities	\$ -	\$ -	\$ -	\$ -	\$ -	\$ -	\$ -	\$ -
Total Current Liabilities	\$ -	\$ -	\$ -	\$ -	\$ -	\$ -	\$ -	\$ -
<i>Long-Term Liabilities</i>								
Long Term Notes Payable	\$ -	\$ -	\$ -	\$ -	\$ -	\$ -	\$ -	\$ -
Other Long Term Liabilities	\$ -	\$ -	\$ -	\$ -	\$ -	\$ -	\$ -	\$ -
Total Long-Term Liabilities	\$ -	\$ -	\$ -	\$ -	\$ -	\$ -	\$ -	\$ -
Total Liabilities	\$ -	\$ -	\$ -	\$ -	\$ -	\$ -	\$ -	\$ -
<i>Owner's Equity</i>								
Capital Stock	\$ -	\$ -	\$ -	\$ -	\$ -	\$ -	\$ -	\$ -
Additional Paid-In Capital	\$ -	\$ -	\$ -	\$ -	\$ -	\$ -	\$ -	\$ -
Retained Earnings	\$ 36,503,806	\$ 70,515,484	\$ 65,621,876	\$ 60,815,011	\$ 56,094,887	\$ 51,461,507	\$ 46,914,868	\$ 42,454,971
Total Equity	\$ -	\$ -	\$ -	\$ -	\$ -	\$ -	\$ -	\$ -
Total Liabilities and Owner's Equity	\$ 36,503,806	\$ 70,515,484	\$ 65,621,876	\$ 60,815,011	\$ 56,094,887	\$ 51,461,507	\$ 46,914,868	\$ 42,454,971

Statement of Cash Flows

	Forecast Period							
	2010	2011	2012	2013	2014	2015	2016	2017
Beginning Cash	\$ -	\$ 89,648	\$ 360,592	\$ 813,835	\$ 1,353,820	\$ 1,980,547	\$ 2,694,016	\$ 3,494,228
CASH FLOWS FROM OPERATING ACTIVITIES:								
Net Income	36,503,806	34,011,678	(4,893,608)	(4,806,865)	(4,720,123)	(4,633,381)	(4,546,639)	(4,459,896)
<i>Adjustments to Reconcile Net Income to Net Cash Provided by Operating Activities</i>								
Add: Depreciation	2,673,425	5,346,850	5,346,850	5,346,850	5,346,850	5,346,850	5,346,850	5,346,850
Add: Amortization	-	-	-	-	-	-	-	-
<i>Changes in Current Assets and Liabilities:</i>								
Marketable Securities	-	-	-	-	-	-	-	-
Accounts Receivable	-	-	-	-	-	-	-	-
Inventory	-	-	-	-	-	-	-	-
Prepayments	-	-	-	-	-	-	-	-
Other Current Assets	-	-	-	-	-	-	-	-
Accounts Payable	-	-	-	-	-	-	-	-
Other Current Liabilities	-	-	-	-	-	-	-	-
Net Cash Provided (Used) by Operations	\$ 39,177,231	\$ 39,358,528	\$ 453,243	\$ 539,985	\$ 626,727	\$ 713,469	\$ 800,212	\$ 886,954
CASH FLOWS FROM INVESTING ACTIVITIES:								
Capital Expenditures	(39,087,584)	(39,087,584)	-	-	-	-	-	-
Amortizable Asset (Net of Amortization)	-	-	-	-	-	-	-	-
Long-Term Investments	-	-	-	-	-	-	-	-
Net Cash Used by Investing Activities	\$ (39,087,584)	\$ (39,087,584)	\$ -	\$ -	\$ -	\$ -	\$ -	\$ -
CASH FLOWS FROM FINANCING ACTIVITIES:								
Notes Receivable	-	-	-	-	-	-	-	-
Notes Payable	-	-	-	-	-	-	-	-
Principal Payments	-	-	-	-	-	-	-	-
New Borrowing	-	-	-	-	-	-	-	-
Additional Paid-in Capital	-	-	-	-	-	-	-	-
Additions to Patronage Capital Credits	-	-	-	-	-	-	-	-
Payment of Dividends	-	-	-	-	-	-	-	-
Net Cash Used by Investing Activities	\$ -	\$ -	\$ -	\$ -	\$ -	\$ -	\$ -	\$ -
Net Increase (Decrease) in Cash	\$ 89,648	\$ 270,945	\$ 453,243	\$ 539,985	\$ 626,727	\$ 713,469	\$ 800,212	\$ 886,954
Ending Cash	\$ 89,648	\$ 360,592	\$ 813,835	\$ 1,353,820	\$ 1,980,547	\$ 2,694,016	\$ 3,494,228	\$ 4,381,182

NPV/IRR Table

	Net Present Value	Internal Rate of Return
Without BTOP Funding	\$0.00	0.00%
With BTOP Funding	\$4,130,030.17	5.06%

Project will not be built without BTOP Funding

Discount Rate		15%	
year	Cash Flows From Operations Amount	year	Cash Flows from Investment Amount
1	\$ 39,177,231	1	\$ (39,087,584)
2	39,358,528	2	(39,087,584)
3	453,243	3	-
4	539,985	4	-
5	626,727	5	-
6	713,469	6	-
7	800,212	7	-
8	7,095,631	8	-

\$ (39,087,584)
\$ (39,087,584)
\$ 39,177,231
\$ 39,358,528
\$ 453,243
\$ 539,985
\$ 626,727
\$ 713,469
\$ 800,212
\$ 7,095,631

Free Cash Flow
\$ 89,648
270,945
453,243
539,985
626,727
713,469
800,212
7,095,631

Revenue Assumptions	
Factor	Specific Metric Used in Analysis
Customers Passed	
Anchor Institutions - Segment A	
Anchor Institutions - Segment B	
Businesses	0
Households	0
Last Mile Providers	0
Other	0
Take Rate (should likely vary across 8-Year Forecast)	
Anchor Institutions - Segment A	20% yr 1, 60% yr2, 100% yrs 3-8 of anchor sites
Anchor Institutions - Segment B	
Businesses	0
Households	0
Last Mile Providers	0
Direct Customer Connections	
Customer Segment A	197
Customer Segment B	
Other	0
Average Revenue per User (may vary across 8-year forecast)	
Anchor Institutions - Segment A	\$972
Anchor Institutions - Segment B	
Businesses	0
Households	0
Last Mile Providers	0
Other	0

Expense Assumptions	
Factor	Specific Metric Used in Analysis
Network Expenses	
Backhaul	0
Maintenance	0

Utilities	0
Leasing	0
Depreciation	separate on income statement
Other	\$590
Sales & Marketing	
Advertising	0
Commissions	0
Salaries	0
Other	0
Customer Care & Billing	
Systems	0
Personnel	0
Other	0
General & Administrative	
Professional Services	0
Insurance	0
Non-Network Utilities	0
Travel	0
Supplies	0
Miscellaneous	\$129
Interest Expenses	
Debt Instrument A	0
Debt Instrument B	0
Taxes	
Federal Tax Rate	0
Other Tax Rates	Business & Occupation Taxes 1.5%

Rationale (Cite Basis)
Last mile providers and cellular companies revenues not forecasted but expected later
no estimates included, conservative estimate
no estimates included, conservative estimate
no estimates included, conservative estimate
no estimates included, conservative estimate
management estimate
no estimates included, conservative estimate
no estimates included, conservative estimate
no estimates included, conservative estimate
Total anchor sites served after 3 years; 10% growth in subsequent years
no estimates included, conservative estimate
Average wholesale price for 100 meg service
no estimates included, conservative estimate
no estimates included, conservative estimate
no estimates included, conservative estimate
Some cellular backhaul expected but not forecast in later years of proforma

Rationale (Cite Basis)
included in average cost of goods sold
included in average cost of goods sold

included in average cost of goods sold
included in average cost of goods sold
calculated in income statement from 7-year life on electronics and 20-year life on fiber and huts
Average cost of goods sold (COGS) across categories
No additional Sales and Marketing allocated; Existing staff sells wholesale to same customers
No additional Sales and Marketing allocated; Existing staff sells wholesale to same customers
No additional Sales and Marketing allocated; Existing staff sells wholesale to same customers
No additional Sales and Marketing allocated; Existing staff sells wholesale to same customers
included in average G&A
included in average G&A
included in average G&A
included in average G&A
included in average G&A
included in average G&A
included in average G&A
included in average G&A
Average G&A across all categories
no additional debt funding
no additional debt funding
not subject to federal tax
Tax on gross receipts applicable unless specific exemption granted in writing by DOR

BTOP Comprehensive Community Infrastructure Service Offerings and Competitor Data Template

Please complete the complete the following worksheets--either of the Last Mile or Middle Mile Service Offerings worksheets may be omitted if the applicant is not proposing to provide that type.

For both the Last Mile and Middle Mile Service Offerings worksheets, the service offerings should include all relevant tiers and markets (*e.g.* residential, business, wholesale). Applicants should ensure to include details on any services that would be offered at discounted rates to specific classes of customers (*e.g.* community anchor institutions or third party service providers).

In the Last Mile Service Offerings worksheet, applicants are required to provide estimated end user speeds. Average speeds should be the average sustained actual, non-burst end user speed that would be received during a peak hour. For purposes of calculating these speeds, applicants should utilize their subscriber projections for year eight of the project, and develop utilization projections that are consistent with any additional services the applicant proposes. For wireless broadband services, this speed should be an average of the speeds available across the entire cell. Beyond these general guidelines, due to the multiplicity of technical solutions that may be proposed, the applicants may use discretion to determine the most reasonable method to estimate actual speeds on their network. Applicants should explain the underlying methodology used to calculate the average speeds in the space provided.

In the Competitor Data worksheet, applicants are required to provide data on both Last Mile and middle mile service providers, regardless of whether the applicant proposes to offer Last Mile and middle mile services. In the column titled Service Areas Where Service Offered, applicants should list all of the Last Mile and Middle Mile Service Areas within their Proposed Project area in which the listed services are available. Please ensure that the Service Areas are consistent with those provided within the application and the Service Areas attached to the application. If the actual availability of the listed services is limited (*e.g.* the service is only available within a specific Last Mile or Middle Mile Service Area), note this in the Other Comments column.

In contrast to several other attachment templates in this application, the data provided in this template will NOT be subject to automated processing. These templates worksheets are provided to demonstrate the level of data required and to provide a suggested format. Applicants may modify the template layouts in order to provide the most effective presentation of data for their specific project. Applicants should, however, ensure that they provide at least as much data as these templates require. To the extent that you modify these templates please ensure that the print layouts are adjusted so that rows do not break across pages in a manner that is difficult to understand. It is recommended that you provide these documents in PDF format when submitting a copy of your application on an appropriate electronic medium, such as a CD-ROM, or flash drive.

Middle Mile
provide services of

offerings should
plans should be
particular
(riders).

estimated average
fast speeds that an
plans, applicants
subscriber
plans to offer.
available across an
solutions that may
manner in which
making assumptions

last mile and
for both last mile
plans, applicants
Funded Service
plan names are
relevant. If the
within part of the

provided via this
plans are provided
applicants are free to
the data for
as much detail
ensure that the
will be difficult
when
as a DVD, CD-

Proposed Last Mile Service Offerings

Name of Service Tier	Advertised Speeds		Estimated Average Speeds		Average Latency	Pricing Plan (\$ per month)	Other Comments/Description/Features or Limitations
	Downstream Mbps	Upstream Mbps	Downstream Mbps	Upstream Mbps	@ End User CPE milliseconds		
Basic Tier	1mbps	1mbps	869 kbps	700 kbps	45	\$19.95	Rates are for new user using customer supplied access cards
Enhanced	3 mbps	1mbps	2.5 mbps	700 kbps	45	\$27.50	Extended range CPE unit if needed available for additional \$85.00 or \$3.95/mo.
Pro Service	6 mbps	1mbps	4.2 mbps	700 kbps	45	\$32.00	
FiberPro	100mbs	100mbs	100mbs	100mbs	15	\$500.00	Business Class Ethernet

Explanation of Average Speed Calculations:

Wireless infrastructure and backhaul with full loading of Public safety, utility and consumer services it be provisioned to provide an average transfer speed of 70% of the advertised transmission speed.

Latency is based on service to a subscriber receiving service from an access point located through a double hop mesh access point. It includes the backhaul, directly connected access point and one intervening mesh access device

Port Angeles Competitor Data

Competitor Data - Last Mile Providers

Service Provider	Service Areas Where Service Available	Technology Platform	Service Tiers	Downstream Speed	Monthly Pricing	Other Comments/Description/Features or Limitations
Qwest	Cam,wpt,wpo,tap,the,ste,qce,ruc,fwn,phk,pas,oig,nms,ndd,mne,iss,kfs,gee	DSL	1.5 Level	1.5 Mbps	\$ 30.00	Internet Only- 1st yr
			7 Level	7.0 Mbps	\$ 35.00	Internet Only- 1st yr
			20 Level	20.0 Mbps	\$ 55.00	Internet Only- 1st yr
Wave Broadband	pas,sbk,	Cable Modem	High Speed 3	3.0 Mbps	\$ 39.50	Internet Only- 1st yr
			High Speed 6	6.0 Mbps	\$ 44.94	Internet Only- 1st yr
			High Speed 18	18.0 Mbps	\$ 49.95	Internet Only- 1st yr
Verizonwireless	Cam,wpt,wpo,tap,the,ste,qce,ruc,fwn,phk,pas,oig,nms,ndd,mne,iss,kfs,gee,wsn,wta,usk,ske,rer,rve,pwd,let,	3G -Wireless	250 MB download	1.4 Mbps	\$ 39.99	
			5 GB download	1.4 Mbps	\$ 59.99	

Competitor Data - Middle Mile Service Providers

Service Provider	Service Areas Where Service Available	Technology Platform	Service Tiers	Distance Band or Point-to-Point	Minimum Peak Load Network Bandwidth Capacity	Pricing	Other Comments/Description/Features or Limitations
Qwest	Cam,wpt,wpo,tap,the,ste,qce,ruc,fwn,phk,pas,oig,nms,ndd,mne,iss,kfs,gee	Sonet	DS-1	Zero Mile	1.5Mbs	\$425	FCC-1 Tariff, 2 chan term 0 mile service
			DS-3	Zero Mile	45Mbs	\$1,625	FCC-1 Tariff, 2 chan term 0 mile service
			OC-3	Zero Mile	155Mbs	\$2,420	FCC-1 Tariff, 2 chan term 0 mile service
Verizon	wsn,wta,usk,ske,rer,rve,pwd,let,mfs,ioe,dmg	Sonet	DS-1	Zero Mile	1.5Mbs	\$560	Tariff 2 chan term 0 mile service
			DS-3	Zero Mile	45Mbs	\$2,100	Tariff 2 chan term 0 mile service
			OC-3	Zero Mile	155Mbs	\$3,340	Tariff 2 chan term 0 mile service
CenturyLink	amp,ash,cwh,cve,crs,cwe,ebe,hrh,jao,lye,mtn,prn,plo,psr,ttt,wpo,whm,zlh,ola	Ethernet	1-3Mbs	Zero Mile	1.5Mbs	\$422	Public Tariff, found in Supplemental Section
			10Mbs	Zero Mile	10Mbs	\$922	Public Tariff, found in Supplemental Section
			100Mbs	Zero Mile	100Mbs	\$3,600	Public Tariff, found in Supplemental Section

Pulled the posted tariffs for the different competitors. These tariffs are mileage dependent penalizing the more rural areas.

When services are available there is generally a mileage component resulting in a higher monthly price. There are discounts available for term.